

SMART WEIGHING SOLUTIONS



rinstrum

400 Series

(K481)

**Summing Indicator
Quick Start Manual**

RI00-619-100

Copyright

All Rights Reserved. No part of this document may be copied, reproduced, republished, uploaded, posted, transmitted, distributed, stored in or introduced into a retrieval system in any form, or by any means (electronic, mechanical, photocopying, recording or otherwise) whatsoever without prior written permission of Rinstrum Pty Ltd.

Disclaimer

Rinstrum Pty Ltd reserves the right to make changes to the products contained in this manual in order to improve design,
performance or reliability.

The information in this manual is believed to be accurate in all respects at the time of publication, but is subject to change without notice. Rinstrum Pty Ltd assumes no responsibility for any errors or omissions and disclaims responsibility for any consequences resulting from the use of the information provided herein.

Table of Contents

1. INTRODUCTION	2
1.1. Manuals	2
1.2. Shipping Contents	2
2. SPECIFICATIONS	3
3. WARNINGS	4
3.1. General	4
3.2. Configuration Issues	4
4. INSTALLATION	5
4.1. Electrical Safety	5
4.2. Panel Mount Template	5
4.3. Function Keys	5
4.4. Optical Communications	6
5. CONNECTIONS	7
5.1. Cable Connections	7
5.2. DC Power (DC PWR +, DC PWR -)	7
5.3. Summing Slave Serial Connection	7
5.4. Auxiliary Connections	8
5.5. Connecting Shields	10
5.6. Regulatory Sealing Requirements	11
6. INSTRUMENT SETUP	12
6.1. Calibration Counter	12
6.2. Access Full Setup	12
6.3. Access Safe Setup	12
6.4. Exit Full or Safe Setup	13
6.5. Slave Indicator Configuration	13
6.6. K481 Summing Indicator Configuration	14
6.7. Using Menus	16
6.8. Settings	17
7. ACCESSORY MODULES	26
7.1. General	26
7.2. Inputs	27
7.3. Outputs	28
7.4. Analog Output	29
7.5. Communications	29
7.6. Ethernet Module	30
8. ERROR MESSAGES	32
8.1. Weighing Errors	32
8.2. Setup Errors	34
8.3. Diagnostic Errors	34

1. Introduction

This manual contains information on the installation and setup of the Indicator.

1.1. Manuals

For more information on the indicator refer to the **Reference Manual** and **Operator Manual**.

1.2. Shipping Contents

The following table identifies the items shipped with indicators. Please check that your packing box contains the specified items.

Standard Indicator	Stainless Steel Indicator
<ul style="list-style-type: none">• Digital Weighing Indicator• Operator Manual• Quick Start Manual• Trade Label (plastic)• Panel Mount Template• Function Key Overlay Stickers	<ul style="list-style-type: none">• Digital weighing Indicator• Operator Manual• Quick Start Manual• Trade Label (plastic)• Function Key Overlay Stickers• Trade Label (metal foil)• M16 Cable Gland Sealing Plug
Other Items (Optional)	
<p>There are many optional accessories for this indicator. These include:</p> <ul style="list-style-type: none">• Mounting options• Power supply options• Expansion modules (which supply additional comms ports, I/O, analog output, etc).• Opto-link temporary connection• PC based configuration tool	

2. Specifications

Performance		
Operating Environment	Temperature: -10 to +50°C ambient Humidity: <90% non-condensing Storage: -20 to +50°C ambient IP55 when panel mounted or with rear boot (otherwise IP40)	
Case Materials	ABS, Silicon Rubber, Nylon, Acrylic (no halogen used)	
Packing Weights	Basic Indicator: 0.6kg	
Digital		
Display	LCD with 4 alpha-numeric displays and LED backlighting: <ul style="list-style-type: none"> • Primary display: 6 x 28.4mm high digits with units and annunciators • 2nd display: 9 x 17.6 mm digits with units • 3rd display: 8 x 6.1mm digits • 4th display: 4 x 7.6 mm digits 	
Setup	Full digital with visual prompting in plain messages	
Power Input		
Standard Power	12 to 24VDC (15 VA max) - ON/OFF key with memory feature	
Variants	AC M4101	Input: 110/240VAC 50/60Hz Output: 12VDC 15VA
	Battery M4102	Rechargeable NiMH battery, 12V, 2.5Ah
Features		
Optical Data Communications	Magnetically attached optical communications support. Optional conversion cable connects directly to a standard RS-232 or USB port.	
Serial Communications	RS-232 serial port for remote display, network or printer supports. RS-485 transmit only for remote display Transmission rate: 2400, 4800, 9600 or 19200 baud	
3 assignable function keys	Printing, slave weights, and totalising	
Battery Backed Clock Calendar	Battery life 10 years minimum	
Approvals	FCC, CE, C-tick Check trade approvals	

3. Warnings

3.1. General

- Indicator not to be subject to shock, excessive vibration or extremes of temperature (before or after installation).
- Inputs are protected against electrical interference, but excessive levels of electro-magnetic radiation and RFI may affect the accuracy and stability.
- For full EMC or for RFI immunity, termination of cable shields and correct earthing of the instrument is essential.
- Indicator is sensitive to excessive electrical noise. Install well away from any power or switching circuits.

3.2. Configuration Issues

- Configuration can be performed from the front panel, using digital setup. When Full Setup is used, all menu items are accessible and care must be taken to ensure no accidental changes are made to calibration and trade settings.
- Enter a passcode to prevent unauthorised or accidental tampering. If the passcode is lost, the manufacturer should be contacted for further advice.

4. Installation

The following steps are required to set up the indicator.

- Inspect indicator to ensure good condition.
- Use connection diagrams to wire up serial summing, power and auxiliary cables as required.
- Use the drilling template provided for hole locations.
- Connect Power to indicator and press **<POWER>** key to turn the instrument ON.
- Refer to the Instrument Setup section page 12 for information on configuring the instrument.
- To turn instrument OFF press and hold **<POWER>** key for three seconds (until display blanks).

4.1. Electrical Safety

- For your protection all mains electrical hardware must be rated for environmental conditions of use.
- Pluggable equipment must be installed near an easily accessible power socket outlet.
- To avoid the possibility of electric shock or damage to the instrument, always switch off or isolate the instrument from the power supply before maintenance is carried out.

4.2. Panel Mount Template

The panel mount template is supplied with the instrument. It shows the location of the rectangular cut-out and the four mounting screws.

4.3. Function Keys

- The Indicator has 3 user definable functions keys.
- If any of the special functions are to be used on the indicator it is important that the matching function key overlay sticker (supplied) is applied to the keypad.
- Ensure keypad is clean and dry before affixing sticker.

4.4. Optical Communications

A temporary infrared communications link can be established between the instrument and a PC using an optional cable. This connection can be used to transfer setup and calibration information from a PC or to download software upgrades.



The PC end of the cable is a standard female DB9 RS232 connector. The instrument end of the cable attaches to the left side of the instrument display.

WARNING

The optical coupling head contains a strong magnet and should not be placed near any magnetic storage media (e.g. credit cards, floppy disks etc.)

5. Connections

5.1. Cable Connections

All cable connections are made to the rear of the instrument using pluggable screw terminals. It is not necessary to tin the ends of the wires with solder or to add crimp ferrules to the wires, however, these techniques are compatible with the terminals.

As this is a summing indicator, the loadcell connection is not required and should not be connected.

COMMS CONNECTIONS

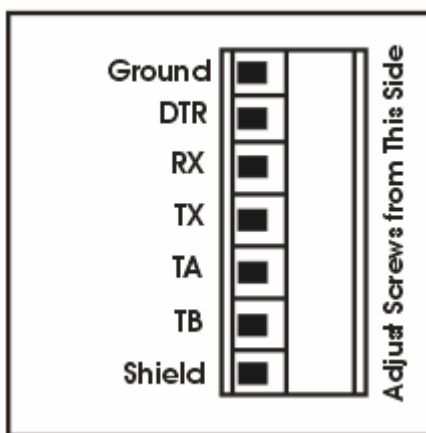

5.2. DC Power (DC PWR +, DC PWR –)

The DC supply need not be regulated, provided that it is free of excessive electrical noise and sudden transients. The instrument can be operated from a high quality plug-pack as long as there is sufficient capacity to drive it.

5.3. Summing Slave Serial Connection

5.3.1. Summing R400 Indicators using RS485

When summing using this configuration, a M4203 module is required for the master and each slave.

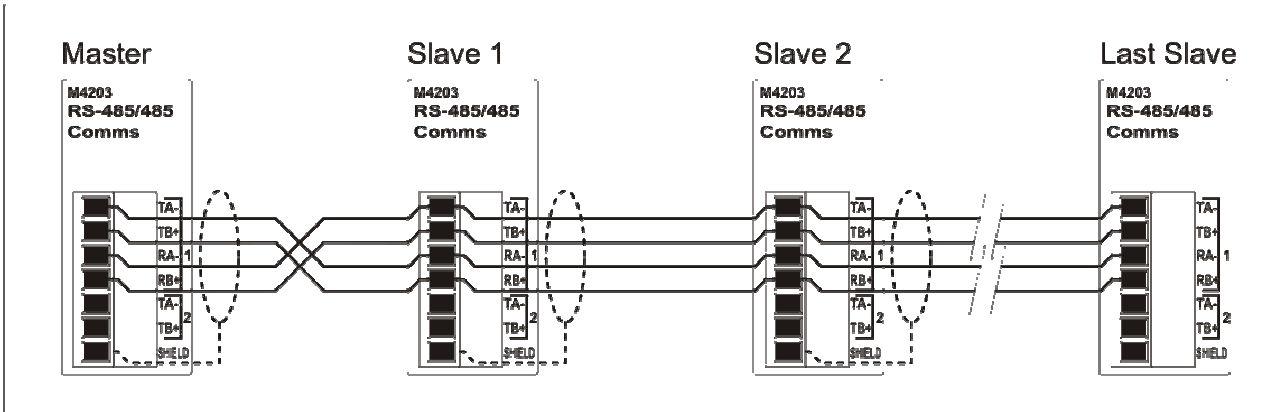

5.3.2. Summing R300 Indicators using RS232 Ring Network

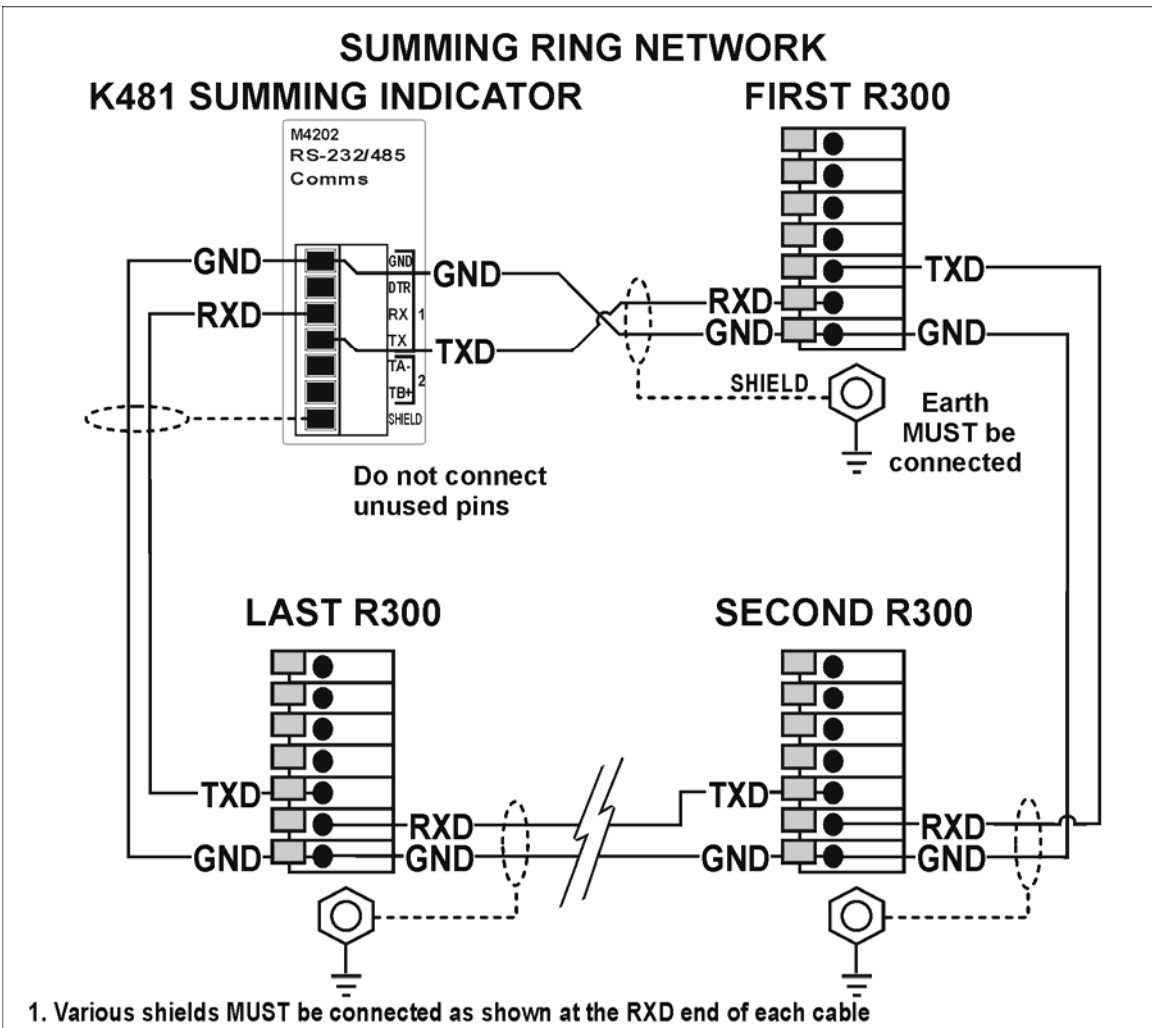

5.4. Auxiliary Connections

This section provides diagrams to illustrate the communication connections.

5.4.1. Direct Personal Computer Link (RX, TX GND)

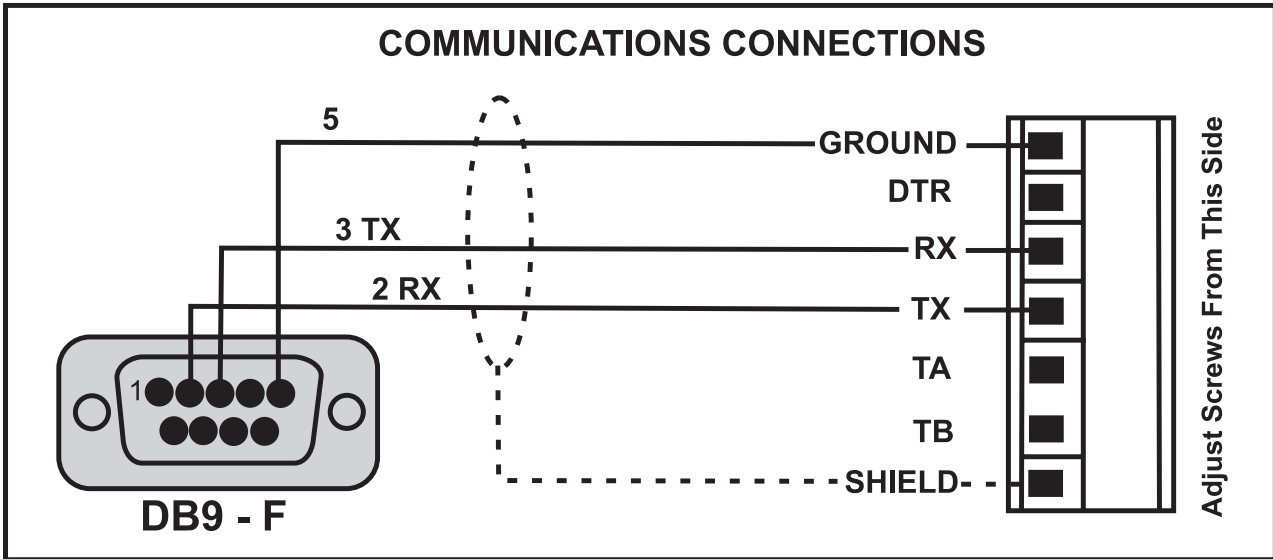

5.4.2. Printer Connections (RXD/TXD, GND and DTR)

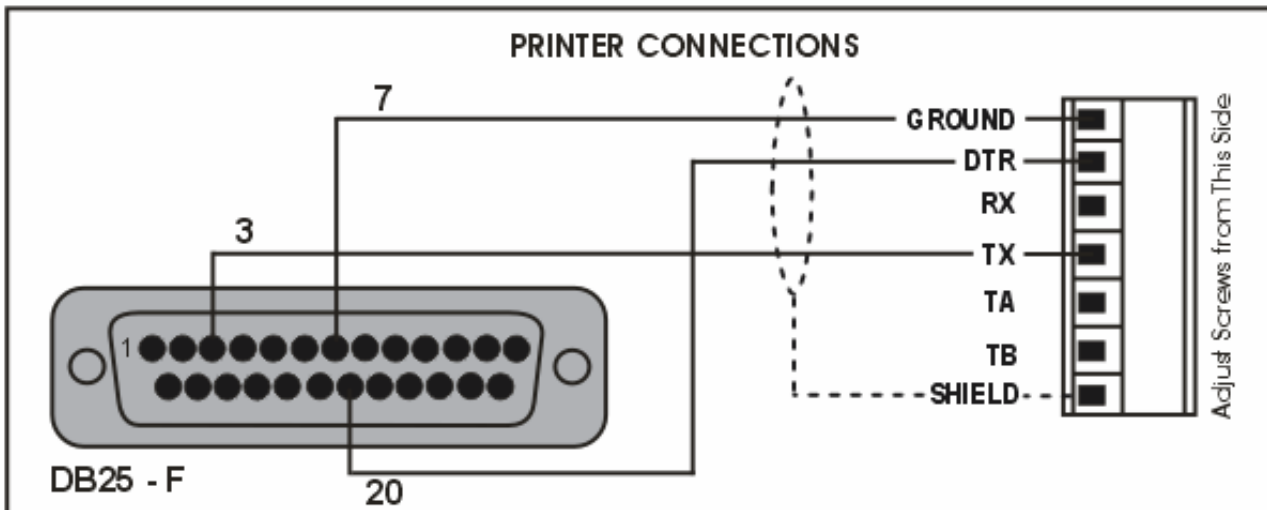

5.4.3. Remote Display using RS232 (TXD, GND)

Refer to documentation supplied with the Remote Display for connection details. Connect RX on the Remote Display with TX on the instrument and connect the RS232 GND signals together.

5.4.4. Remote Display using RS485 (TA, TB)

RS485 is recommended for communicating over distances longer than a few metres. Refer to documentation supplied with the Remote Display for connection details. Connect TA to RA and TB to RB.

5.5. Connecting Shields

To obtain full EMC or for RFI immunity, cable shields **MUST** be connected and the earth lug on the rear of the instrument must be grounded.

This figure illustrates an example of possible connections. Also shown are the connecting cables restrained using cable ties fastened by screws into the rear of the unit.

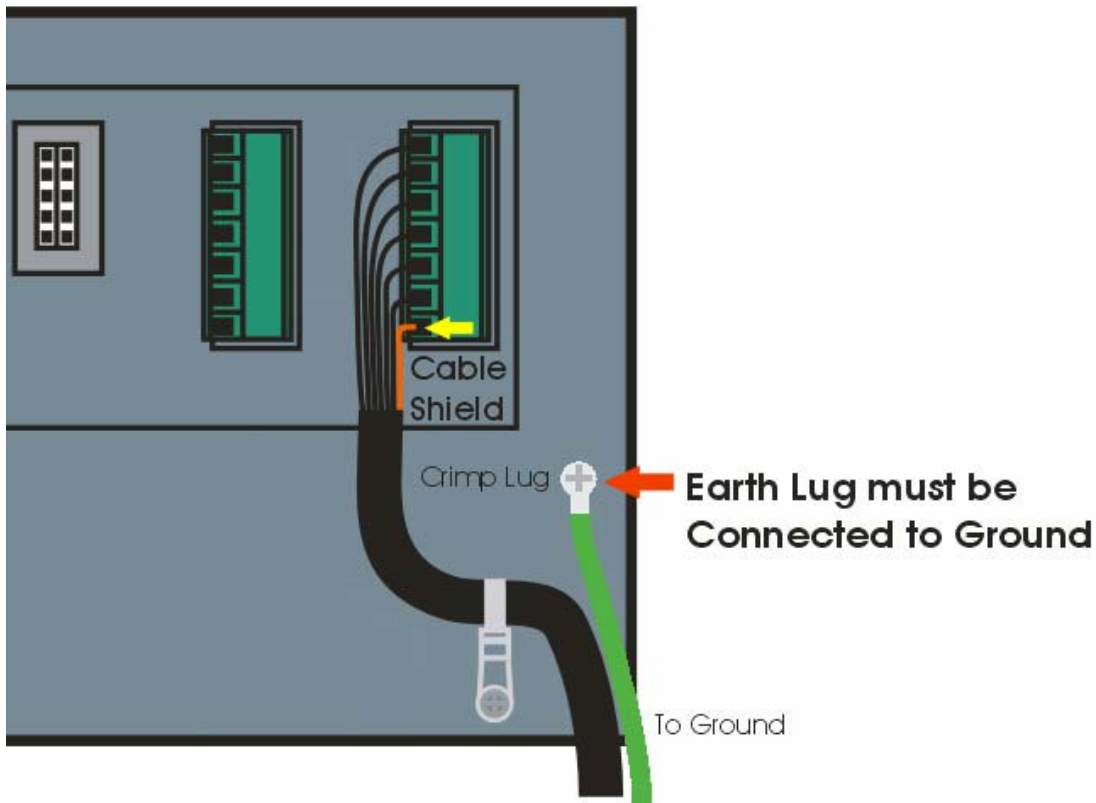
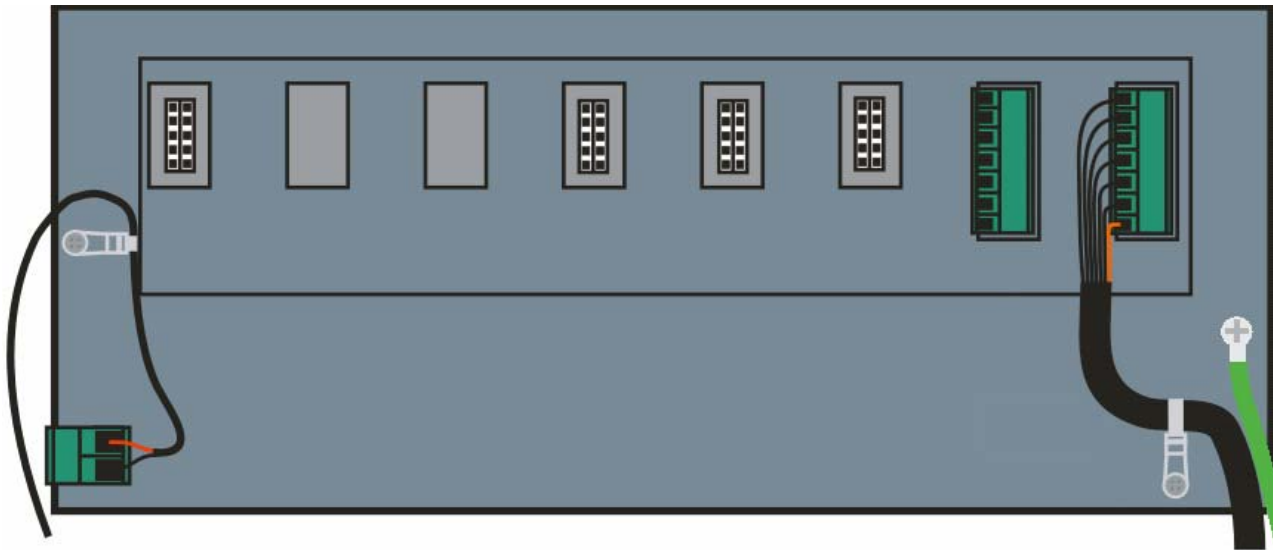

5.5.1. Cable Shield Connection and Earthing

- Care should be taken when connecting shields to maximise EMC or RFI immunity and minimise earth loops and cross-talk (interference) between instruments.
- For full EMC or for RFI immunity, termination of the cable shields at the earth lug is very important. The earth lug of the instrument must be separately connected to ground potential via a reliable link.
- The AC power module directly connects the earth lug to the Earth Pin on the power supply. In installations where earth is available on the power cable, instrument earthing can be done with this connection.
- The instrument should only be connected to earth via a single reliable link to avoid earth loops.
- Where each instrument is separately earthed, interconnecting cable shields should be connected at one end only.

5.6. Regulatory Sealing Requirements

To comply with regulatory sealing requirements for each instrument, (i.e. to ensure instruments are not accidentally or deliberately tampered with), it is important that proper sealing procedures be adhered to.

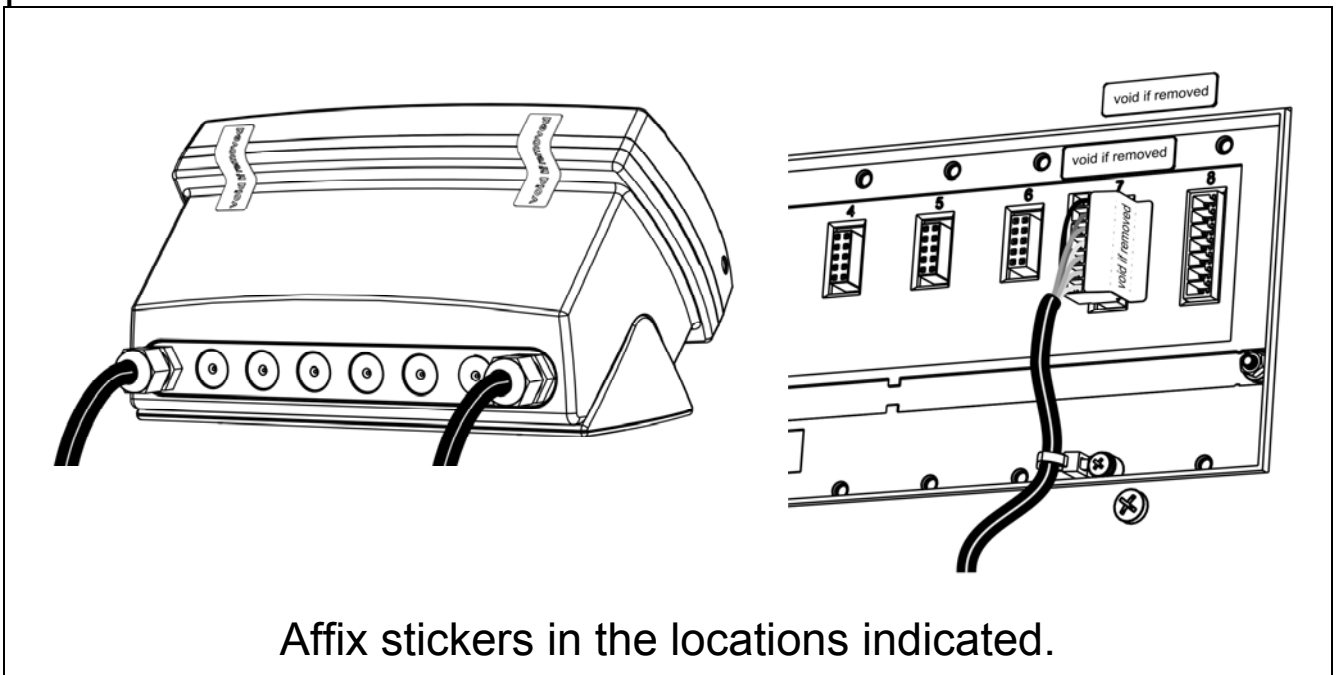

6. Instrument Setup

6.1. Calibration Counter

Within Setup there are a number of critical steps that can affect the legal for trade performance of the instrument. If any of these steps are altered, the trade certification of the scale could be voided.

The instrument provides a built-in calibration counter to monitor the number of times the critical steps are altered. The value of a counter is stored within the instrument and can only be reset at the factory. Each time a critical step is altered, the counter will increase. Whenever the instrument is powered up, or setup mode is entered/exited, the current value in the counter is briefly displayed (e.g. C00010).

The value of the counter is written on the tamperproof trade label on the front of the indicator for trade-certified applications and functions as an electronic seal. If any legal for trade settings are changed on the instrument, the current value of the calibration counter will be different from the recorded value and the seal is broken.

6.1.1. Trade Critical Settings

Trade critical settings can affect legal for trade performance. Each time a trade critical setting is altered, the calibration counter will be incremented by one.

6.2. Access Full Setup

Full Setup provides access to configure and calibrate the instrument. All items in all menus will be enabled in Full Setup.

Ensure the instrument is on.

- Press and hold the <POWER> and end <F₃> keys simultaneously for two seconds.



6.3. Access Safe Setup

Safe Setup restricts access to the trade critical settings (marked with ⊗).

Ensure the instrument is on.

- Press and hold the **<POWER>** and **<ZERO>** keys simultaneously for two seconds.

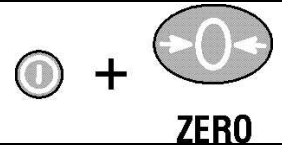

6.4. Exit Full or Safe Setup

To save settings, exit setup and return to the normal weighing mode using one of the following methods:

- Press the **<POWER>** key once.
- Press the **<POWER>** and **<ZERO>** keys together for two seconds.
- Press **<POWER>** and **<F₃>** key together for two seconds

Warning: If the power is interrupted while in setup, unsaved settings will be lost.

6.5. Slave Indicator Configuration

The K481 can only sum one type of indicator, so all slaves must be R300 or all R400 indicators, and not a mix. Each slave must be given a unique address between 1 and the number of slaves to be summed. The K481 can sum a maximum of 9 slaves.

6.5.1. Slave Calibration

Calibrate each slave as per the manuals for the indicator. Each slave must have the same units (eg all Kg). The decimal point position may vary among the slaves.

6.5.2. R320 Slave Configuration

R320 slaves must be running version 3.83 or greater. The following items must be configured in each R300 slave:

- Set SERIAL:TYPE to NET
- Set SERIAL:BAUD to the same baud rate as the summing indicator
- Set SERIAL:BITS to “N81-“
- Set SERIAL:ADDRESS to a unique address between 1 and the number of slaves configured in the summing indicator

6.5.3. R420 Slave Configuration

The slaves must be one of the following:

- K401 Version 1.41 or greater
- K402 Version 1.41 or greater
- K481 Version 1.10 or greater
- K491 Version 1.10 or greater

Summing of K411s is not supported.

The following items must be configured in each R420 slave:

- Set H.WARE:SERx.HW:BAUD to the same baud rate as the summing indicator for the appropriate serial port
- Set H.WARE:SERx.HW:PARITY to NONE for the appropriate serial port
- Set H.WARE:SERx.HW:DATA to 8 for the appropriate serial port
- Set H.WARE:SERx.HW:STOP to 1 for the appropriate serial port
- Set H.WARE:SERx.HW:DTR to OFF for the appropriate serial port
- Set H.WARE:SERx.HW:TERM to ON for the last slave, and off for all other slaves, for the appropriate serial port
- Set SER.NET:TYPE to PROTOCOL.B
- Set SER.NET:SERIAL to the serial port the slave will communicate with the master on
- Set SER.NET:ADDRESS to a unique address between 1 and the number of slaves configured in the summing indicator

6.6. K481 Summing Indicator Configuration

6.6.1. K481 Basic Configuration

The following items must be configured in the K481 summing indicator:

- Set H.WARE:SERx.HW:BAUD to the same baud rate as all the slaves for the appropriate serial port
- Set H.WARE:SERx.HW:PARITY to NONE for the appropriate serial port
- Set H.WARE:SERx.HW:DATA to 8 for the appropriate serial port
- Set H.WARE:SERx.HW:STOP to 1 for the appropriate serial port
- Set H.WARE:SERx.HW:DTR to OFF for the appropriate serial port
- Set H.WARE:SERx.HW:TERM to ON for the appropriate serial port
- Set SER.SUM:SERIAL to the serial port the slave will communicate with the master on
- Set SER.SUM:PROTO to RING when summing R300 indicators via the RS232 ring network, or NORMAL when summing R400 indicators via the RS485 network.
- Set SER.SUM:SLAVES to the number of slaves to be summed.

6.6.2. Slave Name Configuration of the K481 Summing Indicator

Each slave can optionally be named. This name is used on the display when displaying slave weights, and can be used in printouts. The name can be set via the SER.SUM:SLAV.n:NAME menu item. If left blank, the text "SLAVE n" will be used.

6.6.3. Subtotal Configuration of the K481 Summing Indicator

The K481 provides the ability to calculate upto four subtotals from the slave weights. The number of subtotals is set by the SER.SUM:SUB.NUM menu item.

Each subtotal has a name, a list of slaves to add to it, and a list of slaves to subtract from it. The name is configured via SER.SUM:S.TOT.n:NAME menu item. If left blank, the text

“S.TOT n” will be used. The SER.SUM:S.TOT.n:SLV.ADD menu item configures the slaves that should be added to the sub total. For example setting it to 12 will add slaves 1 and 2 to the subtotal. The SER.SUM:S.TOT.n:SLV.SUB menu item configures the slaves that should be subtracted from the sub total. For example setting it to 34 will subtract slaves 3 and 4 to the subtotal.

6.7. Using Menus

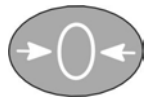

Level 1



Level 2



Level 3



Level 4



Level 5

Example:

GEN.OPT

 L PCODE

 L SAFE.PC

6.8. Settings

MENU	DESCRIPTION	
GEN.OPT	General Options Menu	
L LANG	Operator language	<i>(ENGLISH, GERMAN, DUTCH, FRENCH, POLISH, ITALIAN, SPANISH)</i>
L DATE.F	Date Format	<i>(DD.MM.YY, DD.MM.YYYY, MM.DD.YY, MM.DD.YYYY, YY.MM.DD, YYYY.MM.DD)</i>
L PCODE	Pass Codes	
L SAFE.PC	Safe setup Passcode	<i>(0 .. 999999)</i>
L FULL.PC	Full setup Passcode	<i>(0 .. 999999)</i>
L OP.PC	Operator Passcode	<i>(0 .. 999999)</i>
L KEY.LOC	Key Lock Options	
L P	Power key lock	<i>(AVAIL, LOCKED)</i>
L ZERO,	Zero Key	<i>(AVAIL, OPER.PC, SAFE.PC, LOCKED)</i>
TARE,		
GR_NT,		
F1, F2, F3,		
CLOCK,		
VIEW,		
REPORT,		
TOTAL,		
ID,		
TARGET,		
ACC,		

MENU	DESCRIPTION
PR.MOD, PR.SEL, NUM.PAD ALIBI	
L DISP	Display Options
L B.LIGHT	Backlight operation <i>(ON, OFF)</i>
L FREQ	Display update frequency <i>(1Hz, 2Hz, 3.3Hz, 5Hz, 10Hz)</i>
L VIEW	Default View <i>(PRODUCT, TOP, DUAL)</i>
L ID.NAME	User String Names
L NAME 1 - NAME 3	User ID string names <i>(Maximum 6 characters)</i>
L POWER	Power options
L AUTO.OFF	Auto-off <i>(NEVER, 1 min, 5 min, 10 min, 60 min)</i>
L START	Pause on Start-Up <i>(OFF, ON)</i>
L USR.DEF	User defaults of all items
H.WARE	Hardware Menu
L ALLOC	Check hardware allocation and use

MENU	DESCRIPTION
└ SER1.HW, SER 2.HW	Serial Hardware Menus
└ BAUD.....	Baud rate (_1200_ , _2400_ , _4800_ , _9600_ , _19200_ , _57600_)
└ PARITY.....	Port parity (NONE , EVEN, ODD)
└ DATA.....	Number of data bits (_8_ , _7_)
└ STOP.....	Number of stop bits (_1_ , _2_)
└ DTR.....	DTR Enable (OFF , ON)
└ TERM	RS485 Termination Enable (OFF , ON)
└ RING	Ring Network Enable (OFF , ON) (SER 2 only)
└ ETH.HW	
└ DHCP.....	Port parity (OFF , ON)
└ IP.....	IP Address (Ip Address xxx.xxx.xxx.xxx)
└ NET.MSK.....	Network mask (Ip Address xxx.xxx.xxx.xxx)
└ G.WAY.....	Default gateway (Ip Address xxx.xxx.xxx.xxx)
└ DNS.1.....	Primary Name Server (Ip Address xxx.xxx.xxx.xxx)
└ DNS.2.....	Secondary Name Server (Ip Address xxx.xxx.xxx.xxx)
└ ETH.DEF.....	Ethernet Module Defaults (does not affect indicator settings)
└ IO.HW	Input/Output Hardware Menu
└ FRC.OUT.....	Force outputs test
└ TST.IN.....	Check inputs test
└ DB.1.8 - DB.25.32	Input Debounce Menu's
└ DBNC.1 - DBNC 32	Settings for inputs test (1..250 ms Default: 20ms)

MENU	DESCRIPTION
L ANL.HW	
L TYPE.....	Voltage or current selection (<i>Current, Volt</i>)
L CLIP.....	Output clip enable (<i>NO, YES</i>)
L FRC.OUT.....	Force analog output test
L ANL.CAL	Analog output calibration
L ADJ.LO.....	Adjust low output (4mA or 0V)
L ADJ.HI.....	Adjust high output (20mA or 10V)
L DSD.HW	DSD Hardware Menu
L AUTO.C.....	Auto clear old records (<i>OFF, ON</i>)
L DSD.STR.....	Custom DSD record string (<i>Maximum 20 characters</i>)

MENU	DESCRIPTION	
SER.SUM	Serial Summing menu	
L SERIAL	Summing serial port	(SER1A, SER2A)
L PROTO.....	Summing protocol	(RING, NORMAL)
L SLAVES	Number of slaves	(1 .. 9)
L SLAV.1..SLAV.n	Slave sub menus	
L NAME	Name of each slave	(Maximum 6 characters)
L SUB.NUM.....	Number of sub totals	(0 .. 4)
L S.TOT.1..	Sub total sub menus	
S.TOT.4		
L NAME	Name of each sub total	(Maximum 6 characters)
L SLV.ADD	Slaves to add to subtotal	(0 .. 123456789)
L SLV.SUB	Slaves to subtract from subtotal	(0 .. 123456789)
FUNC	Function menu	
L NUM	Number of special functions	(_1_ .. 8_)
L SF1 – SF8	Function menu	
L TYPE.....	Type	(NONE, PRINT, SINGLE, TEST, PRD.SEL, REM.KEY, BLANK, THUMB, REPORT, SLAVE, SC.EXIT)
L KEY.....	Key selection (Not THUMB)	(NONE, F1 .. F3, IO1 .. IO32)
L PRT.OUT	Print: printout	(NONE, PRINT.1, PRINT.2)
L TOTAL.....	Print: totalizing	(NONE, ADD, UNDO, CKR.ALL, CLR.SESS)
L CLR.ASK	Print: Confirm clear	(NO, YES)

MENU	DESCRIPTION	
└ AUTO	Print: Automatic Print	<i>(NO, YES)</i>
└ IL.TYPE	Print: Interlock type	<i>(NONE, MOTION, I.LOCK, RET.Z)</i>
└ I.LOCK	Print: Interlock	<i>(0 .. Fullscale)</i>
└ AUT.OUT	Single: Auto Output	<i>(AUTO.1, AUTO.2)</i>
└ BLANK	Blank: Blanking function	<i>(DASH, BLANK)</i>
└ IO.BAND	Thumb: Thumbwheel Input	<i>(I01-4 .. I029-31)</i>
└ FUNC	Remote Key: Function to trigger	
SER.NET	Network Menu	
└ TYPE	Protocol type	<i>(NONE, PROTOCOL.B)</i>
└ SERIAL	Serial port	<i>(SER1A, SER2A)</i>
└ ADDR	Network address	<i>(1..31)</i>
SER.AUT	Automatic Output Menu	
└ NUM	Number of Serial outputs	<i>(-1- .. -2-)</i>
└ TYPE	Frequency	<i>(NONE, SINGLE, AUTO.LO, AUTO.HI)</i>
└ SERIAL	Serial port	<i>(SER1A, SER1B, SER2A, SER2B)</i>
└ FORMAT	Format	<i>(FMT.A, FMT.B, FMT.C, FMT.D, FMT.E, FMT.REG, CUSTOM)</i>
└ EV.AUTO	Custom format string	<i>(Token string used with CUSTOM transmissions)</i>

MENU	DESCRIPTION	
PRINT	Print Menu	
L NUM	Number of printouts	(<u>_1_</u> .. <u>_2_</u>)
L HEADER	Header	(String)
L FOOTER.....	Footer	(String)
L PAGE	Print Page Options	
L WIDTH	Page width	(0 .. 250)
L HEIGHT	Page Height	(0 .. 250)
L PG.END	Page End String	(Token String)
L SPACE	Print Margin Options	
L TOP.....	Blank lines at the top	(0 .. 10)
L LEFT	Blank characters on the left	(0 .. 10)
L BOTTOM.....	Blank lines at the bottom	(0 .. 10)
L PRINT.1 -	Print Out Menu's	
PRINT.N		
L TYPE.....	Printout type	(NONE , RECORD , DOCKET , REPORT)
L FORMAT	Format	(FMT.A , FMT.B , CUSTOM)
L NAME	Name	(6 character string)

MENU	DESCRIPTION	
└ CUSTOM	Custom Print Format Strings	
└ REC.PRN ...	Record: Record printout string	
└ DOC.PRN ...	Docket: Docket printout string	
└ EV.D.NEW..	Docket: New docket string	
└ EV.D.END...	Docket: End of docket string	
└ EV.P.NEW..	Docket: New product string	
└ EV.P.END...	Docket: End of product string	
└ REP.ST.....	Report: Start of report string	
└ REP.PR	Report: Each product in a report string	
└ REP.END....	Report: End of report string	
SETP	Setpoint Menu	
└ NUM	Number of Setpoints	(<i>_1_ .. _8_</i>)
└ SETP1 – SETP8	Setpoint Menu	
└ TYPE.....	Type of setpoint	(<i>NONE, ON, OVER, UNDER, COZ, ZERO, NET, MOTION, ERROR, LGC.AND, LGC.OR, LGC.XOR, SC.REDY, EC.EXIT</i>)
└ OUTPUT	Output	(<i>NONE, I01 .. IO32</i>)
└ LOGIC.....	Logic control	(<i>HIGH, LOW</i>)
└ ALARM	Setpoint Alarm	(<i>NONE, SINGLE, DOUBLE, FLASH</i>)
└ SCOPE	Product or global targets	(<i>GLOBAL, PROD</i>)
└ HYS.....	Hysteresis	(<i>0 .. 999999</i>)
└ MASK	Mask for logic setpoints	(<i>0 .. 16777215</i>)
└ RDY.TIM	Ready time for scale entry	(<i>0.000s .. 60.000s</i>)

MENU	DESCRIPTION	
ANL.OUT	Analog Output Menu	
└ ABS	Use absolute weight	<i>(NO, YES)</i>
└ RANGE.....	Weight range	<i>(FULLSCALE, CUSTOM)</i>
└ WGT.LO	Weight at 0V or 4mA	<i>(-999999 .. 999999)</i>
└ WGT.HI.....	Weight at 10V or 20mA	<i>(-999999 .. 999999)</i>
END		
└ END	Save and Close	

7. Accessory Modules

7.1. General

There are many accessory modules which can be used with the indicator.

CAUTION

Instrument should be switched off before connecting or disconnecting accessory modules.

Accessory modules provide additional features such as:

- Power supply options
- Additional communications ports
- Digital inputs and outputs
- Analog outputs
- Additional memory

Refer to the specific module manual for wiring details.

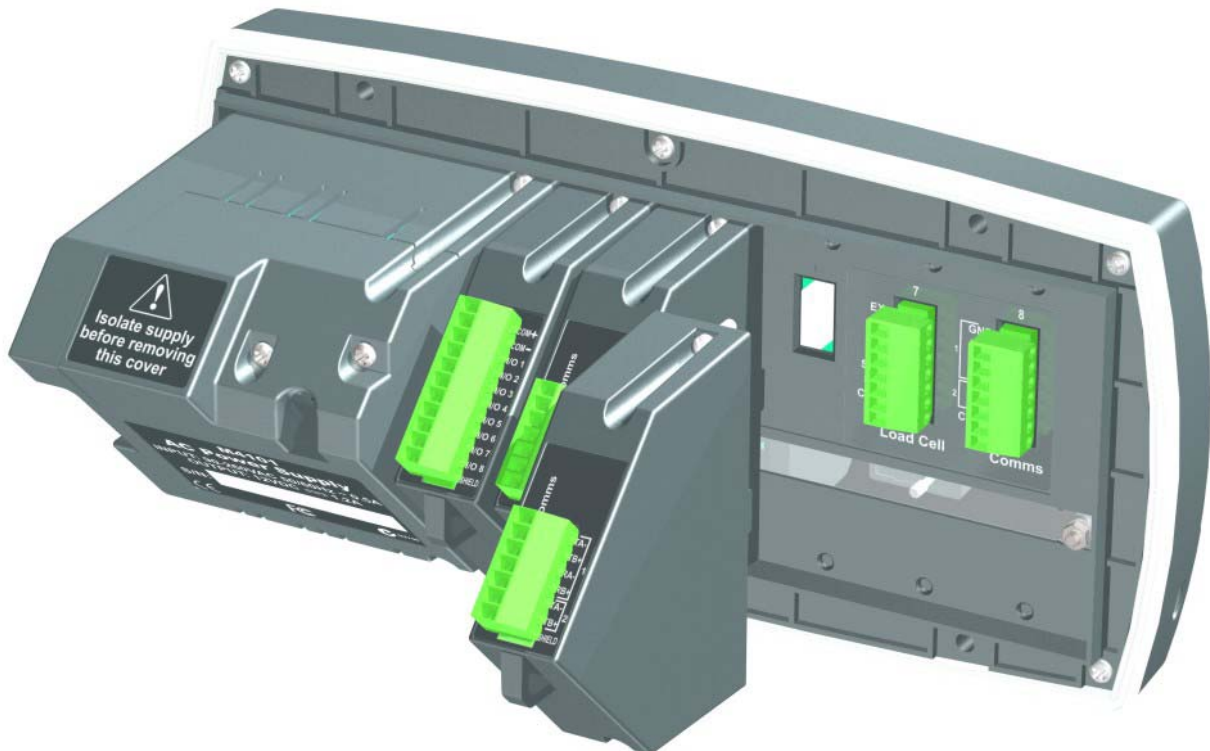

7.2. Inputs

There are several accessory modules which provide inputs. Examples are M4301, M4302 and M4401. Some modules provide I/O which can be inputs or outputs depending on configuration.

7.2.1. Configuration

The instrument has up to 8 special functions. The type of each function is chosen from a list of options. The key which triggers each function can be chosen.

1. Ensure module is connected and instrument is switched on.
2. Enter safe setup (or full setup) and go to the FUNC (special function) menu.
3. FUNC:NUM: The instrument can use up to 8 special functions. This option specifies the number of special functions used.
4. FUNC:SFX: Select the special function to configure.
5. FUNC:SFX:TYPE: Select the type of special function from the list. For example, a PRINT or COUNT key could be specified.
6. FUNC:SFX:KEY: Select the input or button. The I/O range for each module is given in the module manual. For example, M4301 is IO1 to IO8 and M4302 is IO17 to IO20.
7. Other options may appear depending on the type of function chosen. See Settings page 17 for details.

7.2.2. Testing and debugging

Test functions are provided in the HD.WARE:IO.HW menu:

1. HD.WARE:IO.HW:TST.IN (Test Inputs) allows the inputs of each module to be tested. Use the **<UP>** and **<DOWN>** keys to move between modules.
2. HD.WARE:ALLOC (Hardware Allocation) checks the configuration of each item of hardware. Use the **<UP>** and **<DOWN>** keys to move between hardware items.

See also the Troubleshooting section in the module manual.

7.3. Outputs

There are several accessory modules which provide outputs. Examples are M4301 and M4401. Some modules provide I/O which can be inputs or outputs depending on configuration.

7.3.1. Configuration

The instrument has up to 8 setpoint outputs. The type of each setpoint is chosen from a list of options. The physical output used for each setpoint can also be chosen.

1. Ensure module is connected and instrument is switched on.
2. Enter safe setup (or full setup) and go to the SETP (Setpoint) menu.
3. SETP:NUM: The instrument can use up to 8 setpoint outputs. This option specifies the number of setpoints used.
4. SETP:SETPx: Select the specific output to configure.
5. SETP:SETPx:TYPE: Select the setpoint type from the list. For example, an OVER or ERROR setpoint could be specified.
6. SETP:SETPx:OUTPUT: Select the physical output. The I/O range for each module is given in the module manual. For example, M4301 is IO1 to IO8 and M4401 is IO1 to IO2.
7. Other options may appear depending on the type of setpoint chosen. See Settings page 17 for details.

7.3.2. Testing and Debugging

Test functions are provided in the HD.WARE:IO.HW menu:

1. HD.WARE:IO.HW :FRC.OUT (Force Outputs) allows outputs to be manually switched on. The **<UP>** and **<DOWN>** keys change the output and the **<+/->** key switches the outputs on and off.
2. HD.WARE:ALLOC (Hardware Allocation) checks the configuration of each item of hardware. Use the **<UP>** and **<DOWN>** keys to move between hardware items.

See also the Troubleshooting section in the module manual.

7.4. Analog Output

Accessory modules provide analog outputs. An example is the M4401.

7.4.1. Configuration

The instrument can only use a single analog output. Voltage or current output must be chosen. Other settings will function without alteration although they may be customised.

1. Ensure module is connected and instrument is switched on.
2. Enter safe setup (or full setup) and go to the H.WARE:ANL.HW (Analog Output Hardware) menu.
3. H.WARE:ANL.HW.TYPE: Select voltage or current output.
4. Other options are available. See Settings page 17 for details.
5. Additional settings are available in the ANL.OUT (Analog Output Menu). See Settings page 17 for details.

7.4.2. Testing and Debugging

Test functions are provided in the HD.WARE:ANL.HW menu:

1. HD.WARE:ANL.HW:FRC.OUT (Force Output) allows the analog output to be manually set. Use the **<UP>** and **<DOWN>** keys to change the output level.
2. HD.WARE:ALLOC (Hardware Allocation) checks the configuration of each item of hardware. Use the **<UP>** and **<DOWN>** keys to move between hardware items.

See also the Troubleshooting section in the module manual.

7.5. Communications

There are several accessory modules which provide additional communications ports. Examples are M4201, M4202 and M4203.

7.5.1. Configuration

Configuration parameters are divided into hardware (e.g. baud rate or parity) and application (e.g. print format, auto transmit format or networking) settings.

1. Ensure module is connected and instrument is switched on.
2. Enter safe setup (or full setup) and go to the HDWARE:SER2.HW (Serial Port 2 Hardware) menu.
3. HDWARE:SER2.HW: Configure settings for the port. For example, set the baud rate, parity, data and stop bits.
4. Application Settings:
 - a. Networking: Go to the SER.NET menu. Select the port used in SER.NET:SERIAL. Other options are also available. See Settings page 17 for details.
 - b. Automatic Transmit: Go to the SER.AUT menu. Select the port used in SER.AUT:SERIAL. Other options are also available. See Settings page 17 for details.
 - c. Printing: Go to the PRINT menu. Select the port used in PRINT:SERIAL. Other options are also available. See Settings page 17 for details.

7.5.2. Testing and debugging

Setup can be checked in the HD.WARE menu:

1. HD.WARE:ALLOC (Hardware Allocation) checks the configuration of each item of hardware. Use the **<UP>** and **<DOWN>** keys to move between hardware items.

See also the Troubleshooting section in the module manual.

7.6. Ethernet Module

Ethernet connectivity is provided via the M4221 accessory module. This module appears in place of a communications module. SER.2A and SER.2B are routed to the Ethernet module.

7.6.1. Configuration

Configuration parameters are divided into hardware (e.g. IP address, network mask or default gateway) and application (e.g. print format, auto transmit format or networking) settings.

1. Ensure module is connected and instrument is switched on.
2. Enter safe setup (or full setup) and go to the HDWARE:ETH.HW (Ethernet Hardware) menu.

3. HDWARE:ETH.HW: Configure settings for the module. DHCP is often sufficient, however you should obtain correct settings from your network administrator.
4. Application Settings: These settings are identical to the communication module discussed in Section **Error! Reference source not found.**
5. The module supports 1 bi-directional TCP connection on port 2222 representing SER.2A, and upto 10 transmit-only TCP connections on port 2223 representing SER.2B.

7.6.2. Testing and debugging

The current IP configuration can be found under the Acc menu for the module. PC network tools such as “ping” and “telnet” in addition to the viewer software can be used to establish a connection to the indicator over the network. See also the Troubleshooting section in the module manual.

8. Error Messages

Error messages may be displayed to warn of operation outside of the acceptable limits. Short messages (XXXXXX) will appear as a single message. Longer messages (XXXXXX) (YYYYYY) will appear on the display in two parts, first the (XXXXXX) part, then the (YYYYYY) part.

8.1. Weighing Errors

These messages show status messages or errors that may occur during normal weighing operation.

Error	Description	Resolution
(U.LOAD) (O.LOAD)	The weight is below the minimum allowable weight reading or above the maximum allowable weight reading. WARNING: Overloading may damage mechanical scale elements.	Change the weight. Check loadcell connections. Check for damaged loadcell.
(-----)	The summed weight could not be calculated.	Check that all units are displaying positive weight, and all are displaying either gross or net (not a mismatch). If an error code is displayed on the bottom display, refer to Section 0.

8.1.1. Summing Errors

Error	Description
No Resp	One or more slaves are not responding. Slave will be shown in the bottom right display.
Hdr Adr	The address in the command header is bad (ie can't be parsed)
Hdr Cmd	The command in the command header is bad (ie can't be parsed)
Hdr Reg	The register in the command header is bad (ie can't be parsed)
Hdr Dlm	The delimiter in the command header is bad (ie can't be parsed)
Bad Adr	The address in the command header is incorrect (ie different to what was requested)
Bad Rply	The reply was not the expected reply
Not Rply	The response was not a reply
Err Rply	The slave replied with an error
Bad Cmd	The command in the command header is incorrect (ie different to what was requested)
Bad Reg	The register in the command header is incorrect (ie different to what was requested)
Bad Data	The payload could not be parsed
Data Rng	The data in the payload was outside the allowable range
No Slaves	No slaves replied on the ring network
Bad Setup	The summing indicator setup is bad (ie bad number of slaves or subtotals)
Setup Chg	The setup of one of the slaves has changed
Reg Error	One of the slaves is reporting an error when reading a register
Unit.Match	There is a mismatch in the units reported by the slaves (for example mix of kg and t)
Model Err	There is a mix of R300 and R400 indicators on the bus (only the same type of unit can be summed)

8.2. Setup Errors

These errors that may occur during the instrument setup.

Error	Description	Resolution
(ENTRY) (DENIED)	When accessing setup, more than three attempts have been made with the incorrect passcode.	Turn the instrument off and on, then enter the correct passcode to access setup.
(WR DENIED) (RD DENIED)	The instrument may be in Safe Setup and an item that needs Full Setup has been selected for editing.	Access Full Setup to access this item.

8.3. Diagnostic Errors

The instrument continually monitors the condition of the internal circuits. Any faults or out-of-tolerance conditions are shown on the display as an **E** type error message.

Error	Description	Resolution
(E0001)	The power supply voltage is too low.	Check supply
(E0002)	The power supply voltage is too high.	Check supply
(E0010)	Temperature is outside of allowable limits	Check location
(E0020)	Module Error	Replace Module
(E0200)	Calibration data lost.	Re-calibrate
(E0400)	Factory data lost.	Return for Service
(E0800)	Application settings have been set to defaults.	Check and re-enter application settings
(E4000)	The runtime information has been lost.	Check Zero and Tare settings.

Notes

SMART WEIGHING SOLUTIONS

