

F701-C *WEIGHING CONTROLLER*

OPERATION MANUAL

UNIPULSE

07 Jun. 2012
Rev. 1.14



Introduction

We appreciate your kind purchase of F701-C Weighing Controller.

To take full advantage of high performance of F701-C, thoroughly read this operating manual first before use and understand the explanations contained herein for correct operating procedures.

Safety Precautions

Be sure to read for safety.

In order to have an F701-C Weighing Controller used safely, notes I would like you to surely follow divide into  **WARNING** and  **CAUTION**, and are indicated by the following documents. Notes indicated here are the serious contents related safely. Please use after understanding the contents well.

WARNING

Misuse may cause the risk of death or serious injury to persons.

CAUTION

Misuse may cause the risk of injury to persons or damage to property.

WARNING

- Use F701-C with correct supply voltage.
- Do not carry out the direct file of the commercial power supply to a signal input terminal.
- Carefully check wiring, etc. before applying power.
- Do not disassemble the main body for modifications or repair.
- Be sure to ground the protective ground terminal.
- When smoke, a nasty smell, or strange sound, please shut off a power supply immediately and extract a power supply cable.
- Do not install in the following environments.
 - Place s containing corrosive gas or flammable gas.
 - Where the product may be splashed with water, oil or chemicals.
- About the built-in lithium battery
Never disassemble, deform under pressure or throw the battery into fire. The battery may explode, catch fire or leak.
 - Battery
 - Model : CR14250SE made by SANYO Electric Co., Ltd.
 - Nominal voltage : 3V
 - Nominal electric capacity : 850mAh

CAUTION

- Be sure to disconnect the power cable when performing the following.
 - Attachment/detachment of connectors of options.
 - Wiring/connection of cables to terminal blocks.
 - Connection of the ground line.

- Take an interval of more than 5 seconds when repeating ON/OFF.

- For connection to the signal I/O terminal block, wire correctly after checking the signal names and terminal block numbers.
Also, turn off the power of the main body before connection/wiring to the signal I/O terminal block.

- Use shielded cables for the connection of strain gauge type sensor, displacement sensor, External input and output or options.

- Take adequate shielding measures when using at the following locations.
 - Near a power line.
 - Where a strong electric field or magnetic field is formed.
 - Where static electricity, relay noise or the like is generated.

- Do not install in the following environments.
 - Where the temperature and/or humidity exceeds the range in the specifications.
 - Places with large quantities of salt or iron powder.
 - Where the main body is directly affected by vibration or shock.

- Do not use it, broken down.

- When you send F701-C by repair etc., please take sufficient measures against a shock.

CONTENTS

1. APPEARANCE DESCRIPTION	1
1-1. Front Panel	1
1-2. Rear Panel	6
2. CONNECTION	8
2-1. Load cell Connection	8
2-1-1. 6-wire Connection	10
2-1-2. 4-wire Connection	10
2-1-3. Connecting Load cells in Parallel	11
2-2. Connection of the Power Input Terminals	12
2-3. Connection of the Guard Ground	12
2-4. SI/F Connection	12
2-5. Connection of the Control Connector	13
2-5-1. Control Connector-Pin Assignment	13
2-5-2. How to Assemble the Connector	14
2-5-3. Equivalent Circuit (Input)	15
2-5-4. Equivalent Circuit (Output)	15
3. METHODS OF SETTING	16
3-1. Setting Procedure	16
3-1-1. Method of Selecting a Setting Mode	16
3-1-2. Method of Entering a Setting Value	18
3-2. Setting Mode	21
3-2-1. Setting Mode 0	22
3-2-2. Setting Mode 1	24
3-2-3. Setting Mode 2	26
3-2-4. Setting Mode 3	30
3-2-5. Setting Mode 4	32
3-2-6. Setting Mode 5	35
3-2-7. Setting Mode 8	37
4. CALIBRATION	40
4-1. Span Calibration	40
4-2. Span Calibration Procedure	41
4-3. Secondary Calibration Procedure (Equivalent Calibration)	42
4-4. Preparation for Calibration	44
4-4-1. LOCK Release	44
4-4-2. Unit	45
4-4-3. Decimal Place	45
4-4-4. Capacity	46

4-4-5. Minimum Scale Division	46
4-4-6. Balance Weight Value	47
4-4-7. Gravitational Acceleration	47
4-4-8. 1/4 Scale Division	49
4-5. Zero Calibration	50
4-6. Span Calibration	52
4-7. Secondary Calibration (Equivalent Calibration)	53
5. FUNCTION SETTINGS	54
5-1. Display Frequency	54
5-2. Subdisplay Selection	55
5-3. Digital Filter	55
5-4. Analog Filter	56
5-5. Filter in Stable Condition	56
5-6. Motion Detection (MD)	57
5-7. Zero Tracking (ZT)	59
5-8. Digital Zero (DZ)	60
5-9. Digital Zero Clear	61
5-10. Zero Regulation Value	61
5-11. One-touch Tare Subtraction	62
5-12. One-touch Tare Subtraction Reset	63
5-13. Digital Tare Subtraction	64
5-14. Restriction of the Tare Subtraction Function	65
5-15. Switching Gross Weight/Net Weight Display	66
5-16. Reversing Symbol at Discharging Control	67
5-17. Invalidation of Function Keys	67
6. DISCHARGING CONTROL MODE	68
6-1. Feeding Weighing and Discharging Weighing	68
6-1-1. Feeding Weighing	68
6-1-2. Discharging Weighing	71
6-1-3. Discharging Mode	74
6-2. Simple Comparison Control and Sequence Control	75
6-2-1. Simple Comparison	75
6-2-2. Sequential Control	76
6-2-3. Sequence Mode	81
6-3. Auto Free Fall Compensation Regulation / Auto Free Fall Compensation ON/OFF / Average Count of Auto Free Fall Compensation / Auto Free Fall Compensation Coefficient	82

6-4. Final / Set Point 2 / Set Point 1 / Compensation / Over / Under	85
6-5. Near Zero / Upper Limit / Lower Limit	88
6-6. Upper/Lower Limit Comparison / Upper/Lower Limit Comparison Mode / Near Zero Comparison / Final and Comparison / Over/Under Comparison Mode	89
6-7. Complete Signal Output Mode / Complete Output Time / Judging Time / Comparison Inhibit Time / Output Selection 2	91
6-8. Judging Times / AZ Times / At Start Near Zero Confirmation / At Start Weight Value Confirmation / Adjust Feeding / Adjust Feeding Time	94
6-9. Net Over / Gross Over	98
6-10. Weight Error / Sequence Error	99
7. STATISTICAL AND ACCUMULATION FUNCTION SETTING AND OPERATION	100
7-1. Data Display	101
7-2. Accumulation Command	101
7-3. Accumulation Clear	103
7-4. Auto Accumulation Command	105
8. SYSTEM MODE	107
8-1. LOCK (soft)	107
8-2. Password	107
8-3. Self-Check and Memory Clear	108
9. EXTERNAL INPUT/OUTPUT SIGNALS (CONTROL CONNECTOR)	109
9-1. Control Connector-Pin Assignment	109
9-2. Equivalent Circuit (Input)	110
9-3. Equivalent Circuit (Output)	110
9-4. External Input Signal	111
9-4-1. Gross/Net Switching (G/N) <Edge Input> <Level Input>	111
9-4-2. Digital Zero (D/Z ON) <Edge Input>	111
9-4-3. Tare Subtraction (TARE ON) <Edge Input>	112
9-4-4. Tare Subtraction Reset (TARE OFF) <Edge Input>	112
9-4-5. Hold (HOLD) <Level Input>	112
9-4-6. Judge <Level Input>	113
9-4-7. Feed / Discharge <Level Input>	113
9-4-8. Input Signals Used in Sequence Mode	113
9-4-9. Accumulation command <Edge Input>	114
9-4-10. Accumulation Clear <Edge Input>	114

9-4-11. Input Selection	115
9-5. External Output Signal	116
9-5-1. Near Zero	116
9-5-2. Lower Limit, Upper Limit	116
9-5-3. Stable	116
9-5-4. Weight Error	116
9-5-5. Sequence Error	117
9-5-6. RUN	117
9-5-7. Accumulation Error	117
9-5-8. SP1, SP2, SP3	118
9-5-9. Under, Go, Over	119
9-5-10. Complete	120
9-5-11. Output selection	121
10. INTERFACE	122
10-1. 2-wire Serial Interface (S/F)	122
10-1-1. Connection	122
10-1-2. Auto Print Command	122
10-2. RS-232C Interface	123
10-2-1. Communication Specifications	123
10-2-2. Cable	123
10-2-3. Setting Values for RS-232C	124
10-2-4. Communication Mode	124
10-2-5. Transmission Format	126
10-2-6. Communication Format	127
10-3. BCD Parallel Data Output Interface	135
10-3-1. Control Connector-Pin Assignment	135
10-3-2. Equivalent Circuit (Input)	135
10-3-3. Equivalent Circuit (Output)	136
10-3-4. BCD Data Output	136
10-3-5. Polarity Output (MINUS)	136
10-3-6. Over Status Output (OVER)	137
10-3-7. Print Command Output (P.C)	137
10-3-8. Data Strobe (STROBE)	137
10-3-9. BCD Data Update Rate Selection	138
10-3-10. Data Hold Input	138
10-3-11. Logic Switching Input	138
10-3-12. Output Selection Input	138
10-4. D/A Converter	139
10-4-1. Name of Each Part	139
10-4-2. Specifications	141
10-4-3. Method of Adjusting the D/A Zero and Gain	141
10-4-4. About D/A Resolution	143
10-5. RS-485 Communication Interface	144
10-5-1. Communication Specifications	144
10-5-2. RS-485 Connection	144
10-5-3. Setting Values for RS-485	145
10-5-4. Communication Method	146
10-5-5. Communication Format	147

11. OVER SCALE & ERROR	155
11-1. Over Scale	155
11-2. Sequence Error	155
11-3. Calibration Error	155
12. TROUBLE SHOOTING	156
13. REPLACEMENT OF THE BACKUP BATTERY	163
14. BLOCK DIAGRAM	164
15. DIMENSIONS	165
16. MOUNTING ON A PANEL	166
17. SPECIFICATIONS	167
17-1. Analog Section	167
17-2. Display Section	168
17-3. Setting Section	168
17-4. External Input/Output	169
17-5. Interface	169
17-6. General Performance	171
17-7. Attachment	172
18. THE LIST OF INITIAL SETTING VALUE	173
18-1. Setting Mode 0	173
18-2. Setting Mode 1	173
18-3. Setting Mode 2	174
18-4. Setting Mode 3	174
18-5. Setting Mode 4	174
18-6. Setting Mode 5	175
18-7. Setting Mode 8	175
18-8. Calibration Mode (Setting Mode 9)	175

1. APPEARANCE DESCRIPTION

1-1. Front Panel

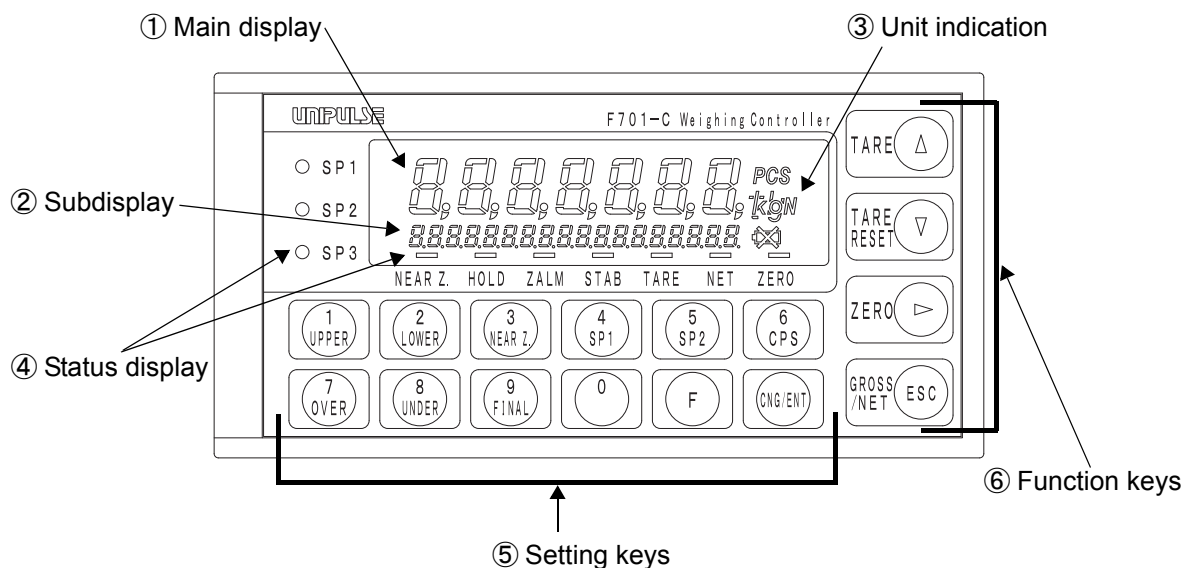

① Main display

The following three types are displayed.

(1) Weight value display

Displays the Gross weight or the Net weight.

When error occurred, the display shows error and weight value alternately.

(2) Over scale and error display

Over-scale, sequence errors and calibration errors are displayed.

※ Please refer to "11.OVER SCALE & ERROR" on P.155.

(3) Setting value display

Various final discharge setting values and setting values for adjustment, such as Final and Set Point 2, are displayed.

② Subdisplay

Weighing data, such as Accumulation Value, and various setting values are displayed by setting.

※ Please refer to "・ Function Selection" on P.31, "5-2.Subdisplay Selection" on P.55.

- (1) Accumulation Count, Accumulation Value

The diagram shows a 12-digit LED display. The first four digits are grouped by a bracket and labeled "Accumulation Count". The remaining eight digits are grouped by a bracket and labeled "Accumulation Value".

- (2) Latest Accumulation Data, Accumulation Value

The diagram shows a 12-digit LED display. The first four digits are grouped by a bracket and labeled "Latest Accumulation Data". The remaining eight digits are grouped by a bracket and labeled "Accumulation Value".

- (3) Accumulation Count, Latest Accumulation Data, Final

The diagram shows a 12-digit LED display. The first four digits are grouped by a bracket and labeled "Accumulation Count". The next four digits are grouped by a bracket and labeled "Latest Accumulation Data". The last four digits are grouped by a bracket and labeled "Final".

- (4) Final, Over, Under

The diagram shows a 12-digit LED display. The first four digits are grouped by a bracket and labeled "Final". The next four digits are grouped by a bracket and labeled "Over". The last four digits are grouped by a bracket and labeled "Under".

- (5) Near Zero, Upper Limit, Lower Limit

The diagram shows a 12-digit LED display. The first four digits are grouped by a bracket and labeled "Near Zero". The next four digits are grouped by a bracket and labeled "Upper Limit". The last four digits are grouped by a bracket and labeled "Lower Limit".

- (6) None

The diagram shows a 12-digit LED display with all digits blank.



Accumulation Count	Displays the count accumulated by the auto accumulation command or external input/output signal, or through RS-232C communication, etc.
Accumulation Value	Displays the value accumulated by the auto accumulation command or external input/output signal, or through RS-232C communication, etc.
Latest Accumulation Data	Displays the latest data accumulated by the auto accumulation command or external input/output signal, or through RS-232C communication, etc.
Final	Displays the “Final” value set in the setting mode 0-9.
Over	Displays the “Over” value set in the setting mode 0-7.
Under	Displays the “Under” value set in the setting mode 0-8.
Near Zero	Displays the “Near zero” value set in the setting mode 0-3.
Upper Limit	Displays the “upper limit” value set in the setting mode 0-1.
Lower Limit	Displays the “lower limit” value set in the setting mode 0-2.



③ Unit indication

The unit can select from six types: t, kg, g, N, lb and None.

④ Status display



SP1	Lights when the Set Point 1 signal is ON.
SP2	Lights when the Set Point 2 signal is ON.
SP3	Lights when the Set Point 3 signal is ON.
NEAR Z.	Lights when the Near Zero signal is ON. “ NEAR Z. ”
HOLD	Lights when the weight value is held. “ HOLD ”
ZALM	Lights when the DZ Regulation Value is exceeded in Digital zero/Zero tracking operation. “ ZALM ” (Such as when any load cell has a problem with its zero point.)
STAB	Lights when the weight value is stable. “ STAB ”
TARE	Lights when Tare subtraction is performed. Flashes when the Tare weight is displayed. “ TARE ”

NET	Lights when the weight value display is Net weight. Goes out when it is Gross weight.	
ZERO	<ul style="list-style-type: none"> • Lights at a true zero point ($0 \pm 1/4$ scale division). (When the 1/4 scale division display is OFF under Function Selection in setting mode 3.) • Lights at a true zero point ($0 \pm 1/4$ scale division), and at the central point of the scale interval of the indicated value (indicated value $\pm 1/4 \times$ Min. Scale Division). (When the 1/4 scale division display is ON under Function Selection in setting mode 3.) 	
	Flashes when the voltage of the lithium battery for memory backup has dropped. Replace with a new battery. For the method of replacement, refer to "13.REPLACEMENT OF THE BACKUP BATTERY" on P.163.	

※ The expression “” in this instruction manual shows that 「」 on the status display lights, goes out, or flashes.

⑤ Setting keys



When the  key is pressed, the Tare weight is displayed, and “” flashes.

(When the Tare weight display with the  key is valid under Restriction on the Tare Subtraction Function in setting mode 4.)

To go back to the weight display, press the  key again.



Numerical keys to make settings.



Function key to switch the setting mode.



Change/Enter key to confirm setting items and setting values.

⑥ Function keys



Key to perform one-touch Tare subtraction.

“” on the status display lights. (In setting mode 0)



However, Tare subtraction is performed only in the following cases depending on the setting of Restriction on the Tare Subtraction Function in setting mode 4.

- When the weight value is stable (when “” is on).
 - When the range of Tare subtraction is $0 < \text{Tare} \leq \text{Capacity}$.
- Use as an increment key for setting operation.



Key to reset Tare subtraction. (In setting mode 0)
 However, the Tare Weight is not cancelled.
 Use as a decrement key for setting operation.



When  →  is pressed, Gross is zeroed immediately. (In setting mode 0)
 However, if this operation is performed with Gross out of the DZ Regulation Value, “ $\overline{\text{ZALM}}$ ” flashes.
 (For details of the DZ Regulation Value, refer to "5-10.Zero Regulation Value" on P.61.)

To discontinue, press the  key.
 Use to shift setting values for setting operation.



Switch the weight display (Gross/Net). (In setting mode 0)
 Pressing on Gross weight display (when “ $\overline{\text{NET}}$ ” is OFF) switches to Net weight display, and pressing on Net weight display (when “ $\overline{\text{NET}}$ ” is ON) switches to Gross weight display.
 However, the display cannot be switched with this key if the switching Gross weight/Net weight display is set to external input mode under External Function Selection in setting mode 4.
 Use as an ESC key for setting operation.



Functioning of the Function keys can be invalidated by setting of "5-17.Invalidation of Function Keys" on P.67.

1-2. Rear Panel

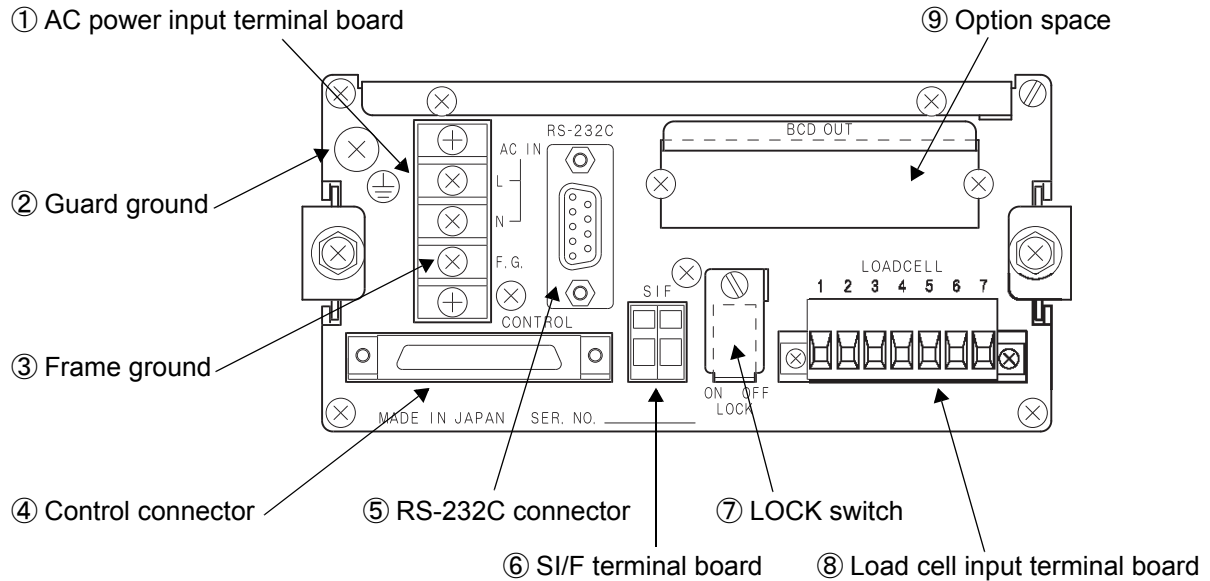

① AC power input terminal board

Connect AC power code. The input voltage is 100V ~ 240V AC.
The frequency is 50/60Hz.

② Guard ground

This is a guard ground terminal board. Be sure to ground the guard ground terminal to prevent electric shocks and failures due to static electricity. (The frame and the guard ground terminal are conducted.)

③ Frame ground (Functional ground)

This is a F.G. terminal of AC input. (The frame and the F.G. terminal are conducted.)

④ Control connector

This is a connector to input external signals and output control signals. The Input/Output circuit and internal circuit are photocoupler-insulated electrically.

The applicable connector is the following (accessory) manufactured by Fujitsu Component or an equivalent:

Connector : FCN-361J024-AU
Cover : FCN-360C024-B

⑤ RS-232C connector

RS-232C connector for receiving and transmitting weight data and status information.
The applicable connector is JAE DE-09SN or its equivalent.

⑥ S/I/F terminal board

2-wire serial interface is to connect unipulse peripheral equipment such as printer, remote display or data converter.

⑦ LOCK switch

LOCK switch for avoiding changes of setting value, it prohibits to change setting value while the switch is ON.

⑧ Load cell input terminal board

This is a terminal board to connect load cell(s).
The applicable terminal board is Osada-manufactured ETB42-07P.

⑨ Option space

One of the following options can be mounted.

- BCD parallel data output interface (BCO)
- D/A converter (DAC)
- RS-485 communication interface (485)
- CC-Link interface (CCL)

2. CONNECTION

2-1. Load cell Connection

The voltage application of F701-C is 10V, and the maximum current is 120mA, to which up to four 350 Ω load cells can be connected in parallel.

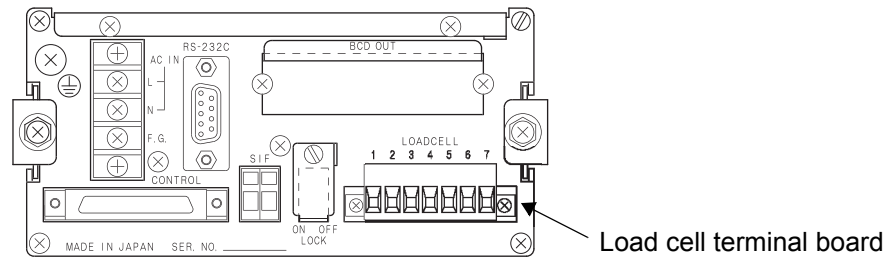

Load cell terminal board pin assignments

Pin No.	Signal (6-wire)	Signal (4-wire)
1	+SIG	+SIG
2	-SIG	-SIG
3	+EXC	+EXC
4	+S	(Connect 3 to 4)
5	-EXC	-EXC
6	-S	(Connect 5 to 6)
7	SHIELD	SHIELD

Method of connection

1) Peel the sheath of the wire to be connected 5mm.

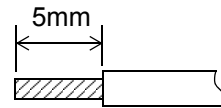

2) Twist the end to such an extent that it will not become loose.

3) Remove the terminal board from the F701-C body with a strong pull.

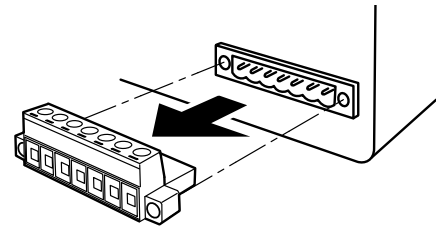

4) Loosen the screw with a screwdriver to open the hole.
A Phillips screwdriver with a shaft diameter of 3 ~ 3.5mm #1 is recommendable (precision screwdriver, etc.).

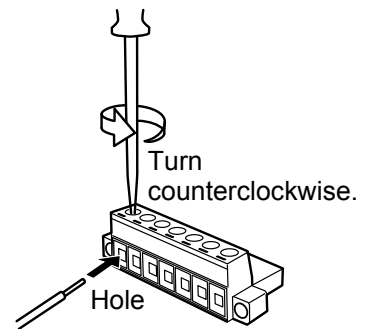

5) Insert the wire into the hole so as not to loosen the end.

6) Tighten the screw with the screwdriver.

7) Lightly pull the wire to check that it is clamped securely.

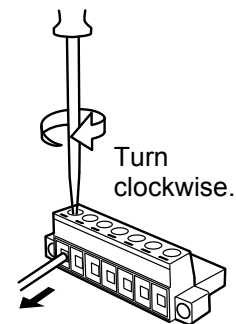

※ Connectable wires are 0.21 ~ 3.31mm² (AWG12 ~ 24).
Recommendable tightening torque is 0.5Nm.

8) Insert the wire-connected plug into the F701-C body, and tighten the screws (two).

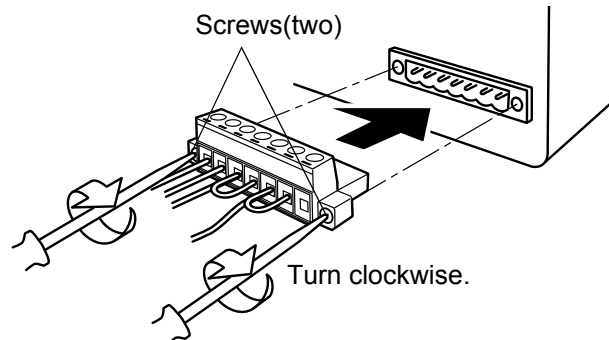

Request

When mounting the terminal board to the F701-C body, check its vertical orientation. (See the illustration on the right-hand side.)

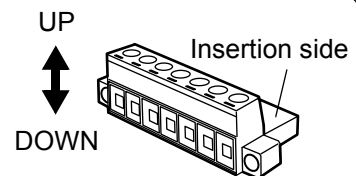

2-1-1. 6-wire Connection

The load cell input of the F701-C is a 6-wire (remote sense) connection. 6-wire shielded load cell cable should be used and kept separate from AC or other noise generating wire.

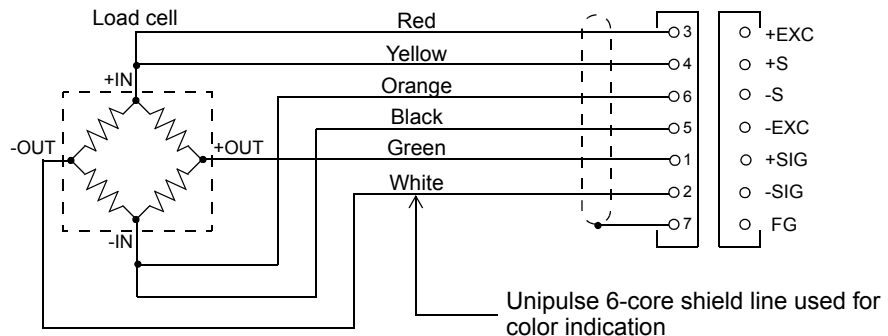

※ Remote sense lines are used to detect and correct variations in excitation voltage over long cable runs.

2-1-2. 4-wire Connection

Connect 3 and 4, and 5 and 6 as shown below.

Even 4 and 6 on the terminal board are open, normal operation is performed apparently, but heating or breakage may occur because excessive voltage is applied to the load cell.

For connection, use the accessory jumper lines.

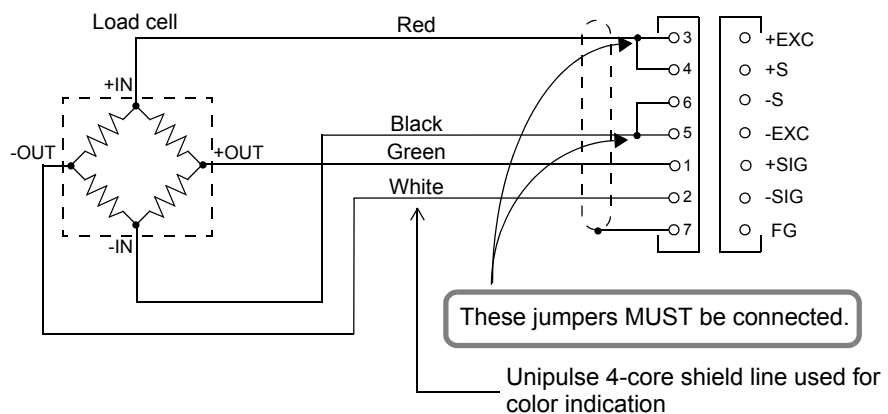

⚠ CAUTION

- The load cell excitation voltage of the F701-C is 10V. Heating or breakage may occur unless the load cells maximum excitation voltage is 10V or more.
- When using the F701-C with the four-wire load cell connected, be sure to connect +EXC and +S, and -EXC and -S. Even if +S and -S are not connected, normal operation is performed apparently, but heating or breakage may occur because excessive voltage is applied to the load cell.

2-1-3. Connecting Load cells in Parallel

In some industrial weighing apparatus, two or more load cells may be connected in parallel to form a hopper scale or track scale. The manner of connection is shown below. Parallel connection can simply be made by using the optionally available B410 (summing box for 4-point multi load cell).

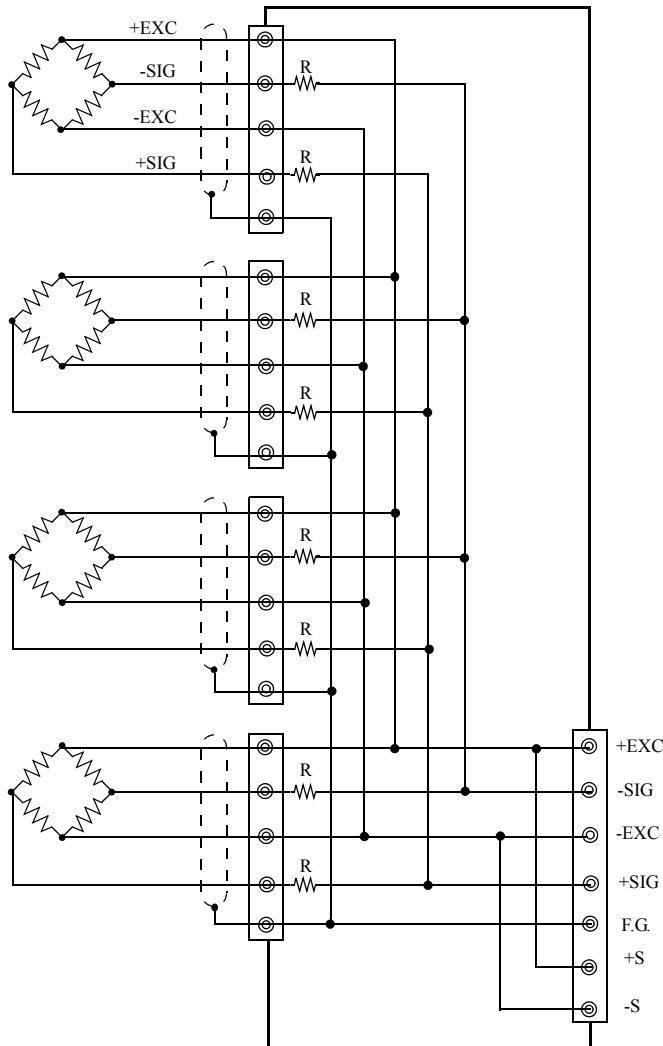

The group of “n” parallel load cells viewed from this device side can be regarded as a unit load cell the rated capacity of which is multiplied by “n” and the sensitivity of which is unchanged. The averaging resistance (R) should be 300 ~ 500 Ω, equal in relative ratio and excellent in temperature coefficient. No averaging resistance is needed if load cells with consideration for parallel connection are used.

Request

When connecting several load cells in parallel, load cell capacity should be higher than expected load to compensate for mechanical shock or eccentric loading.

2-2. Connection of the Power Input Terminals

Connect AC power cord. The input voltage is 100V ~ 240V AC.
The frequency is 50/60Hz.

1) Remove the terminal board cover.

2) Connect the AC power cords.

Connect to the terminal board after attaching crimp contacts (M3) so as not to loosen the ends of the cables as shown in the illustration.

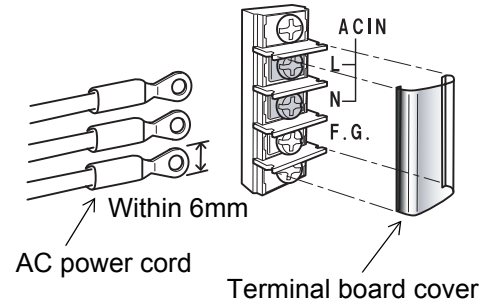

3) Mount the terminal board cover.

2-3. Connection of the Guard Ground

The grounding terminal is for prevention of electric shocks and failures caused by static electricity.

Use an approx. 0.75mm^2 thick wire, and be sure to ground.

2-4. SI/F Connection

The SI/F allows connection of up to three nonpolarized external devices.

As for wire materials, use parallel 2-core cables, cabtyre cables, or the like.

Connect to the cage clamp type terminal board by using the attached mini screwdriver.

1) Strip the casing 0.2in (6mm) on the cable to be connected.

Twist the bare wire to fit the terminal hole.

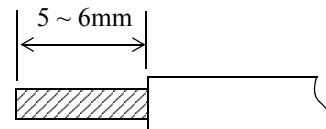

2) Insert the supplied screwdriver into the upper hole and lift upward.

3) Insert the twisted wires into the lower hole.

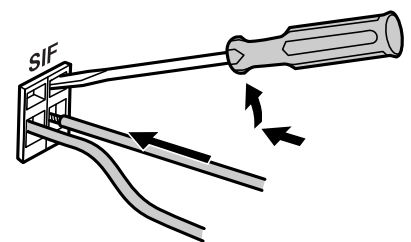

4) Pull the screwdriver out from the upper hole.

5) Make sure cable is clamped securely and does not come out with a slight tug.

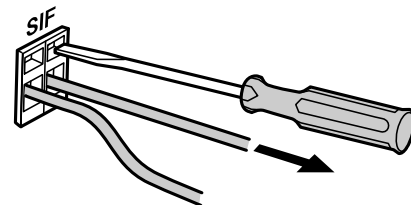

Request

- Cable can be from 24 ~ 14AWG ($0.2 \sim 2.5\text{mm}^2$).
- It is not necessary to solder the cable wires or to fix a solderless terminal.
- If several cables to be inserted to the same hole, twist those cable wires together and insert.

2-5. Connection of the Control Connector

Connect to the control connector (rear panel "CONTROL").

The applicable connector is the following (accessory) manufactured by Fujitsu Component or an equivalent:

Connector : FCN-361J024-AU
Cover : FCN-360C024-B

2-5-1. Control Connector-Pin Assignment

For details, please refer to "9.EXTERNAL INPUT/OUTPUT SIGNALS (CONTROL CONNECTOR)" on P.109.

A1	*	COM	B1	*	COM
A2	In	G/N	B2	In	Input Selection 1 *1
A3	In	D/Z ON	B3	In	Input Selection 2 *1
A4	In	Tare Subtraction ON	B4	In	Input Selection 3 *1
A5	In	Tare Subtraction OFF	B5	In	Input Selection 4 *1
A6	Out	Near Zero	B6	Out	Lower Limit
A7	Out	SP1	B7	Out	Upper Limit
A8	Out	SP2	B8	Out	Stable
A9	Out	SP3	B9	Out	Output Selection 1 *2
A10	Out	Under	B10	Out	Output Selection 2 *2
A11	Out	Over	B11	Out	Output Selection 3 *2
A12	*	COM	B12	*	COM

※ * : The COM (common) terminals are connected inside.

※ *1 : Selectable by setting.

(For details, please refer to "9-4-11.Input Selection" on P.115)

※ *2 : Selectable by setting. (For details, please refer to "6-10.Weight Error / Sequence Error" on P.99, "6-7.Complete Signal Output Mode / Complete Output Time / Judging Time / Comparison Inhibit Time / Output Selection 2" on P.91, "9-5-7.Accumulation Error" on P.117)

※ SP1 turns ON when Weight value \geq Final - SP1

SP2 turns ON when Weight value \geq Final - SP2

SP3 turns ON when Weight value \geq Final - CPS

2-5-2. How to Assemble the Connector

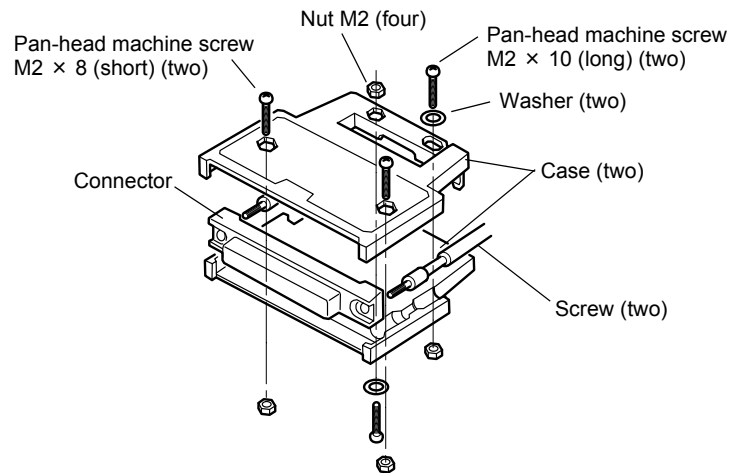

- (1) Set the connector and screws (two) into the grooves of the case (one side).
- (2) Cover with the other case, and fit the cases.
- (3) Tighten the M2 × 8 pan-head machine screws (two).
Tighten the M2 × 10 pan-head machine screws (two).
Be aware that washers should be set to the M2 × 10 pan-head machine screws (two).

2-5-3. Equivalent Circuit (Input)

A signal is inputted to the signal input circuit by short-circuiting or opening the input terminal and the COM terminal. Short-circuiting is effected by means of a contact (such as a relay or a switch) or a noncontact (such as a transistor or an open-collector TTL).

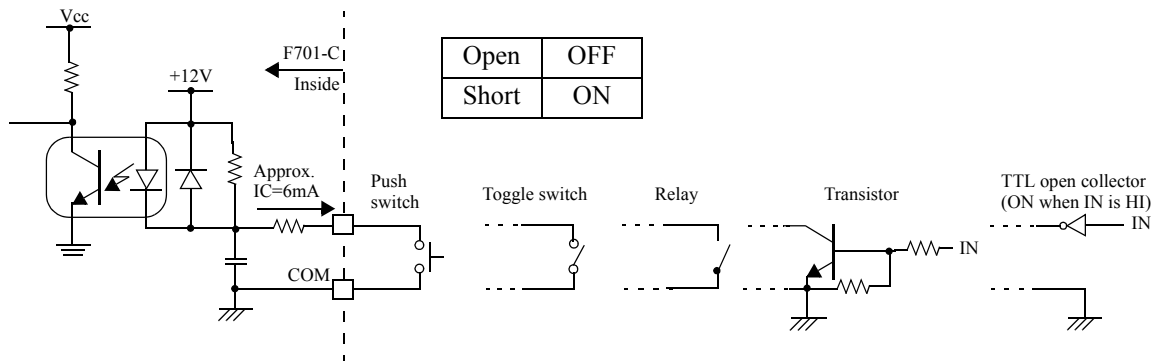

- Do not apply external voltage to the signal input circuit.
- The external element is required to withstand $I_c=10\text{mA}$.
- Leakage from the external element is required to be $100\ \mu\text{A}$ or below.

2-5-4. Equivalent Circuit (Output)

The signal output circuit is open-collector output of a transistor.

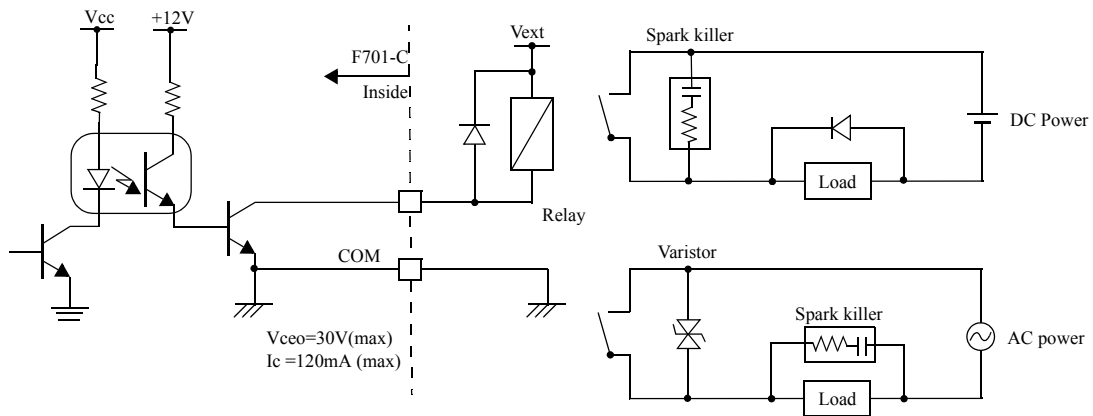

• Transistor status

Output data	Tr
0	OFF
1	ON

- Use external power source (up to DC30V) for driving relay (V_{ext}).
- Do not short-circuit the load, such as a coil of relay, that will break the output transistor.
- Connect a surge absorber or a spark killer to the relay circuit as shown in the draft so that to reduce noise trouble and extend the life of relay. Noise trouble can be reduced, and the relay's life can be extended.

3. METHODS OF SETTING

3-1. Setting Procedure

Change settings in the order of “setting mode selection” → “setting item selection” → “setting value entry”.

3-1-1. Method of Selecting a Setting Mode

In the text, the method of selecting a setting mode is described as follows:

(Example) For selecting setting mode 3

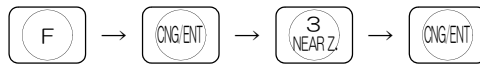

This operation can be performed by the following procedure.

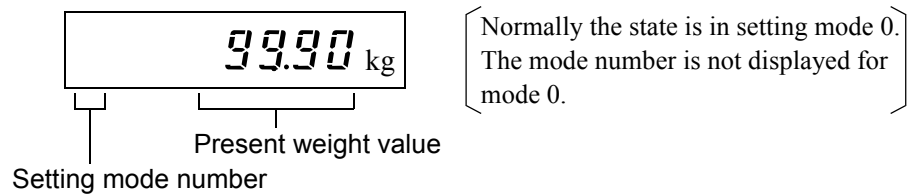

1) Press the key when the weight value is displayed.

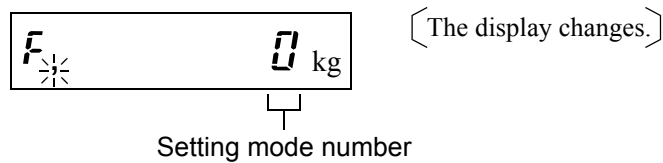

2) Press the key.

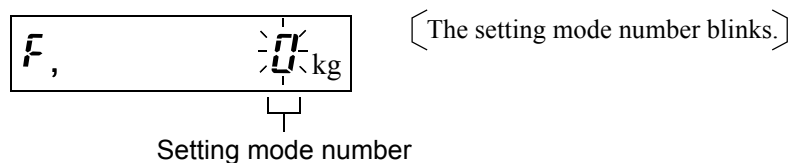

3) Select the setting mode number. ()

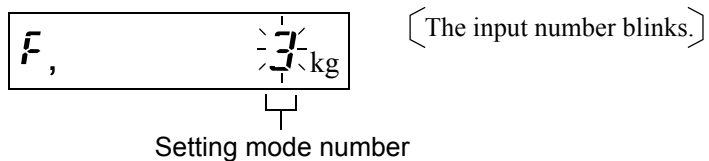

4) Press the  key.

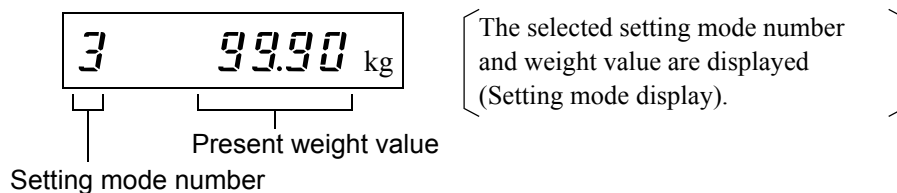

By pressing the  key when the setting mode number is displayed, you can go back to normal display (Setting mode 0).

3-1-2. Method of Entering a Setting Value

In the text, the method of entering a setting value is described as follows:

**(Example 1) For setting the Balance Weight Value to 50.00kg
(Setting by numerical input)**

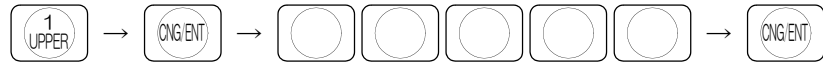

This operation can be performed by the following procedure.

※ However, it is assumed that setting mode 3 has already been selected.

1) Select the setting item.

(Since the setting item number of the Balance Weight Value is 1,

press the key.)

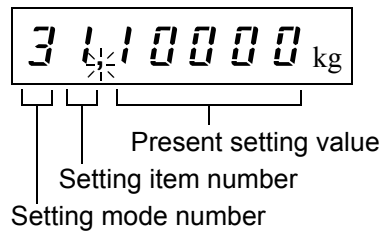

The setting mode number, setting item number, and present setting value are displayed.

2) Press the key.

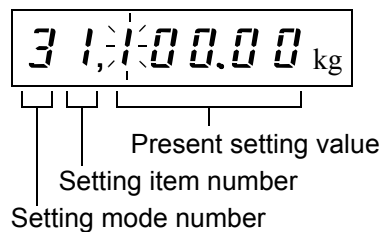

The highest digit of the setting value blinks.

3) Input the setting value. ()

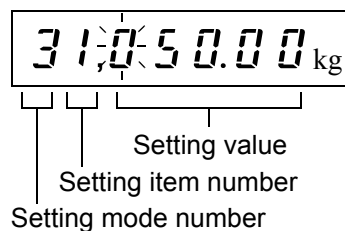

Every time a number is pressed, the blinking digit moves to the lower one. Since the highest digit starts blinking again after a number is input to the lowest digit, setting can be redone again and again.

4) After the correct setting value is input, press the key to enter the setting value.

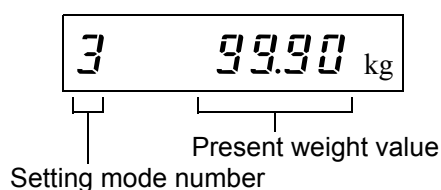

The display returns to the setting mode display.

**(Example 2) For setting the 1/4 scale division display to OFF
(Setting from choices)**



This operation can be performed by the following procedure.

※ However, it is assumed that setting mode 3 has already been selected.

1) Select the setting item.

(Since the setting item number of the 1/4 scale division display is 7, press the key.)

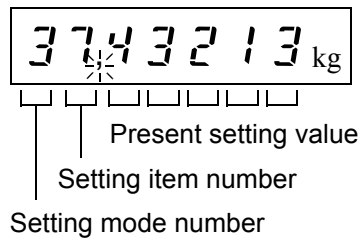

The setting mode number, setting item number, and present setting value are displayed.

2) Press the key.

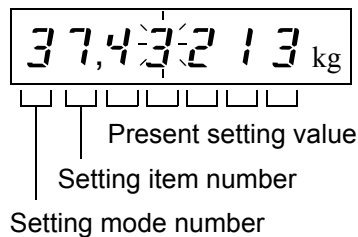

The highest digit of the setting value blinks.

3) Move with the key until the digit you want to set blinks.

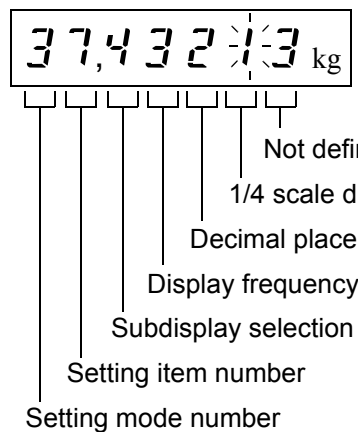



Every time the key is pressed, the blinking digit moves to the lower one.

4) Select from choices.

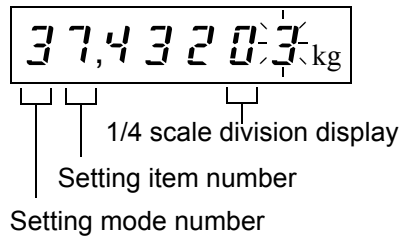
(Since the 1/4 scale division display should be turned off, press )



The blinking digit moves to the lower one. Since the blinking digit moves every time the  key is pressed, setting can be redone again and again.

5) After the correct choice is input, press the  key to enter the choice.

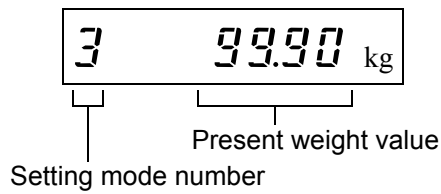













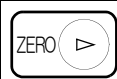

The display returns to the setting mode display.



By pressing the  key when the setting item number is displayed (while changing a setting value after selecting an item), you can exit the item.
(The display returns to the setting mode display.)

3-2. Setting Mode

	Setting mode 0	Setting mode 1	Setting mode 2	Setting mode 3
	Upper Limit / P.22	Comparison Inhibit Time / P.24	Weighing Function 1 / P.26	Balance Weight Value / P.30
	Lower Limit / P.22	Judging Time / P.24	Weighing Function 2 / P.27	Capacity / P.30
	Near Zero / P.22	Complete Output Time / P.24	Weighing Function 3 / P.27	Min. Scale Division / P.30
	Set Point 1 / P.22	Adjust Feeding Time / P.24	Sequence Mode / P.28	Net Over / P.30
	Set Point 2 / P.22	Auto Zero Times / P.24	Function Key Invalid / P.28	Gross Over / P.30
	Compensation / P.22	Judging Times / P.24	Digital Filter / P.28	DZ Regulation Value / P.30
	Over / P.23	Auto Free Fall Compensation Regulation / P.25	Motion Detection / P.29	Function Selection / P.31
	Under / P.23	Analog Filter / P.25	Zero Tracking Period / P.29	Gravitational Acceleration (area number) / P.31
	Final / P.23	Tare Weight / P.25	Zero Tracking Range / P.29	Gravitational Acceleration (acceleration) / P.31
	_____	_____	_____	_____

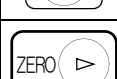
	Setting mode 4	Setting mode 5	Setting mode 8	Setting mode 9
	D/A Output Mode / P.32	Input Selection / P.35	Average Weight / P.37	Span Calibration / P.52
	D/A Zero Output Weight / P.32	Output Selection / P.35	Max. Value / P.37	Equivalent Calibration / P.53
	D/A Full Scale / P.32	CC-Link I/F Number of occupied station & Transmission speed (Refer to separate-volume spec.)	Min. Value / P.37	_____
	RS-485 I/F / P.32	CC-Link I/F Station No. (Refer to separate-volume spec.)	General Standard Deviation / P.37	_____
	ID Number / P.33	_____	Sample Standard Deviation / P.37	_____
	RS-232C I/F / P.33	_____	Accumulation Count (n) / P.37	_____
	External Function Selection / P.34	_____	Latest Accumulation Data / P.37	_____
	Setting Value LOCK / P.34	_____	Max. - Min. (R) / P.38	_____
	Restriction on the Tare Subtraction Function / P.34	_____	Option Board / P.38	Pass Word / P.107
	_____	_____	_____	Zero Calibration / P.50

※ When each setting mode is selected, the 1 ~ 9 keys function as setting item selection keys.

3-2-1. Setting Mode 0

In setting mode 0, setting values for final discharging control are to be set.

• Upper Limit



(For details, please refer to "6-5" on P.88.)

• Lower Limit



(For details, please refer to "6-5" on P.88.)

• Near Zero



(For details, please refer to "6-5" on P.88.)

• Set Point 1

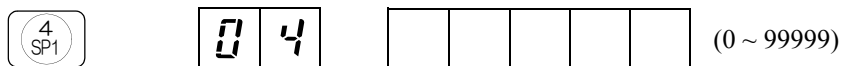

(For details, please refer to "6-4" on P.85.)

• Set Point 2

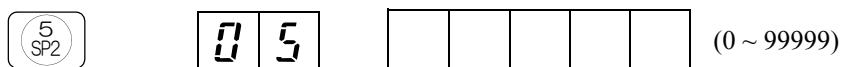

(For details, please refer to "6-4" on P.85.)

• Compensation



(For details, please refer to "6-4" on P.85.)

• **Over**

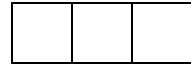
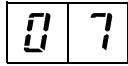

(0 ~ 999)

(For details, please refer to "6-4" on P.85.)

• **Under**

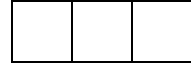
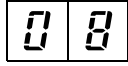

(0 ~ 999)

(For details, please refer to "6-4" on P.85.)

• **Final**

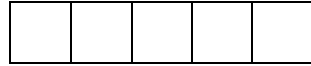
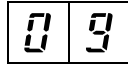

(0 ~ 99999)

(For details, please refer to "6-4" on P.85.)

3-2-2. Setting Mode 1

In setting mode 1, output signals for final discharging control and parameters in sequence mode, etc., are to be set.

• Comparison Inhibit Time

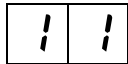

sec. (0.00 ~ 9.99)

(For details, please refer to "6-7" on P.91.)

• Judging Time

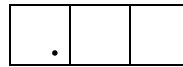
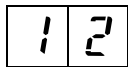

sec. (0.00 ~ 9.99)

(For details, please refer to "6-7" on P.91.)

• Complete Output Time

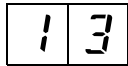

sec. (0.00 ~ 9.99)

(For details, please refer to "6-7" on P.91.)

• Adjust Feeding Time (Effective when selecting sequence mode)

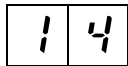

sec. (0.00 ~ 9.99)

(For details, please refer to "6-8" on P.94.)

• Auto Zero Times (Effective when selecting sequence mode)

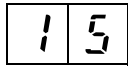

(0 ~ 99)

(For details, please refer to "6-8" on P.94.)

• Judging Times (Effective when selecting sequence mode)

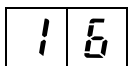

(0 ~ 99)

(For details, please refer to "6-8" on P.94.)

• **Auto Free Fall Compensation Regulation**

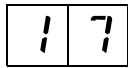

--	--	--	--	--	--

(0 ~ 99999)

(For details, please refer to "6-3" on P.82.)

• **Analog Filter**

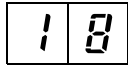

--

(0 ~ 3)

(For details, please refer to "5-4" on P.56.)

• **Tare Weight**

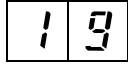

--	--	--	--	--	--

(0 ~ 99999)

(For details, please refer to "5-13" on P.64.)

3-2-3. Setting Mode 2

In setting mode 2, the display and internal functions of the F701-C are to be tuned.

• Weighing Function 1

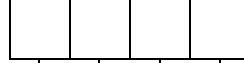
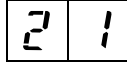

Discharging control mode

- 2 : External selection
- 1 : Discharging control
- 0 : Feeding control

(For details, please refer to "6-1-3" on P.74.)

Final and Over/Under comparison

- 2 : Comparison OFF
- 1 : Net weight
- 0 : Gross weight

(For details, please refer to "6-6" on P.89.)

Near Zero comparison

- 4 : ON when $|\text{Net weight}| \leq \text{Near Zero setting value}$
- 3 : ON when $|\text{Gross weight}| \leq \text{Near Zero setting value}$
- 2 : Comparison OFF
- 1 : ON when $\text{Net weight} \leq \text{Near Zero setting value}$
- 0 : ON when $\text{Gross weight} \leq \text{Near Zero setting value}$

(For details, please refer to "6-6" on P.89.)

Upper/Lower limit comparison

- 2 : Comparison OFF
- 1 : Net weight
- 0 : Gross weight

(For details, please refer to "6-6" on P.89.)

• Weighing Function 2

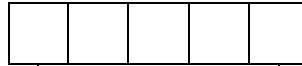
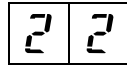

※ Not defined

Accumulation command selection

- 1 : Auto accumulation command ON
- 0 : Auto accumulation command OFF

(For details, please refer to "7-4" on P.105.)

Over/Under comparison mode

- 3 : Comparison is made, and the weight value is held when the complete output is ON.
- 2 : Comparison is made when the complete output is ON.
- 1 : Comparison is made when the external judgment input is ON.
- 0 : Comparison regularly

(For details, please refer to "6-6" on P.89.)

Complete signal output mode

- 2 : ON for the complete output time from when the judging timer has expired or from when the weight value becomes stable after the SP3 signal turns ON.
- 1 : ON for the complete output time from when the weight value becomes stable after the judging timer has expired.
- 0 : ON for the complete output time from when the judging timer has expired.

(For details, please refer to "6-7" on P.91.)

Upper/Lower limit comparison mode

- 1 : Comparison is made when the external judgment input is ON.
- 0 : Comparison regularly

(For details, please refer to "6-6" on P.89.)

• Weighing Function 3

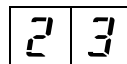

- 3 : AFFC. coefficient 1/4
- 2 : " 2/4
- 1 : " 3/4
- 0 : " 1

(For details, please refer to "6-3" on P.82.)

- 2 : AFFC. ON
(Communication OP invalid)
- 1 : " ON
- 0 : " OFF

(For details, please refer to "6-3" on P.82.)

- 1 : Digital tare subtraction ON
- 0 : Digital tare subtraction OFF

(For details, please refer to "5-13" on P.64.)

Average count of AFFC.
(1 ~ 9)

(For details, please refer to "6-3" on P.82.)

• Sequence Mode

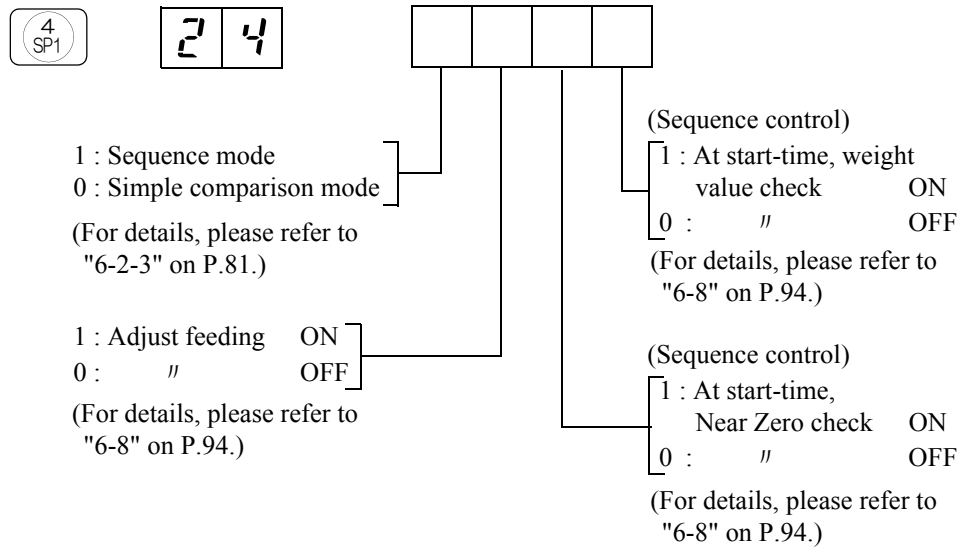

• Function Key Invalid

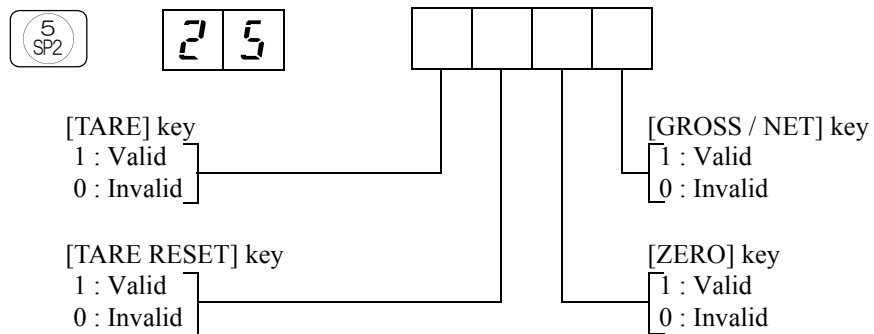

(For details, please refer to "5-17" on P.67.)

• Digital Filter

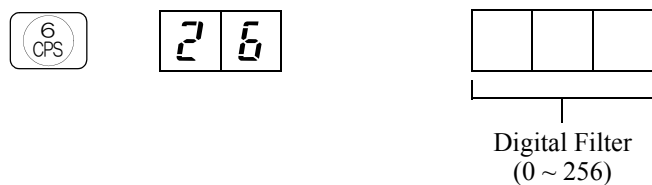

(For details, please refer to "5-3" on P.55.)

• **Motion Detection**

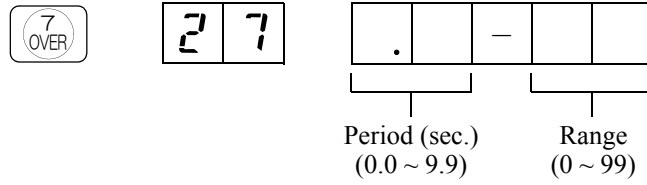

※ Set the stability detection parameter.

(For details, please refer to "5-6" on P.57.)

• **Zero Tracking Period**

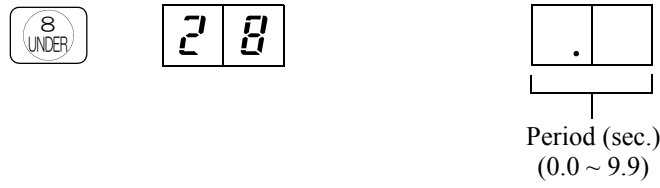

(For details, please refer to "5-7" on P.59.)

• **Zero Tracking Range**

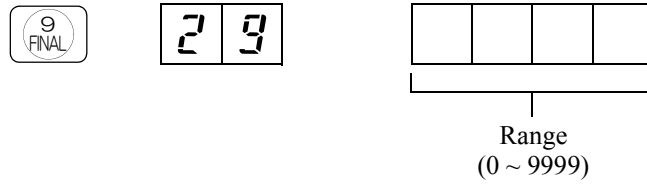

(For details, please refer to "5-7" on P.59.)

3-2-4. Setting Mode 3

In setting mode 3, setting values relating to initial calibration are to be set.

• Balance Weight Value

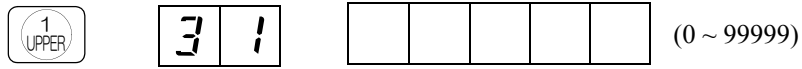

(For details, please refer to "4-4-6" on P.47.)

• Capacity



(For details, please refer to "4-4-4" on P.46.)

• Min. Scale Division



(For details, please refer to "4-4-5" on P.46.)

• Net Over



(For details, please refer to "6-9" on P.98.)

• Gross Over



(For details, please refer to "6-9" on P.98.)

• DZ Regulation Value



(For details, please refer to "5-10" on P.61.)

• **Function Selection**

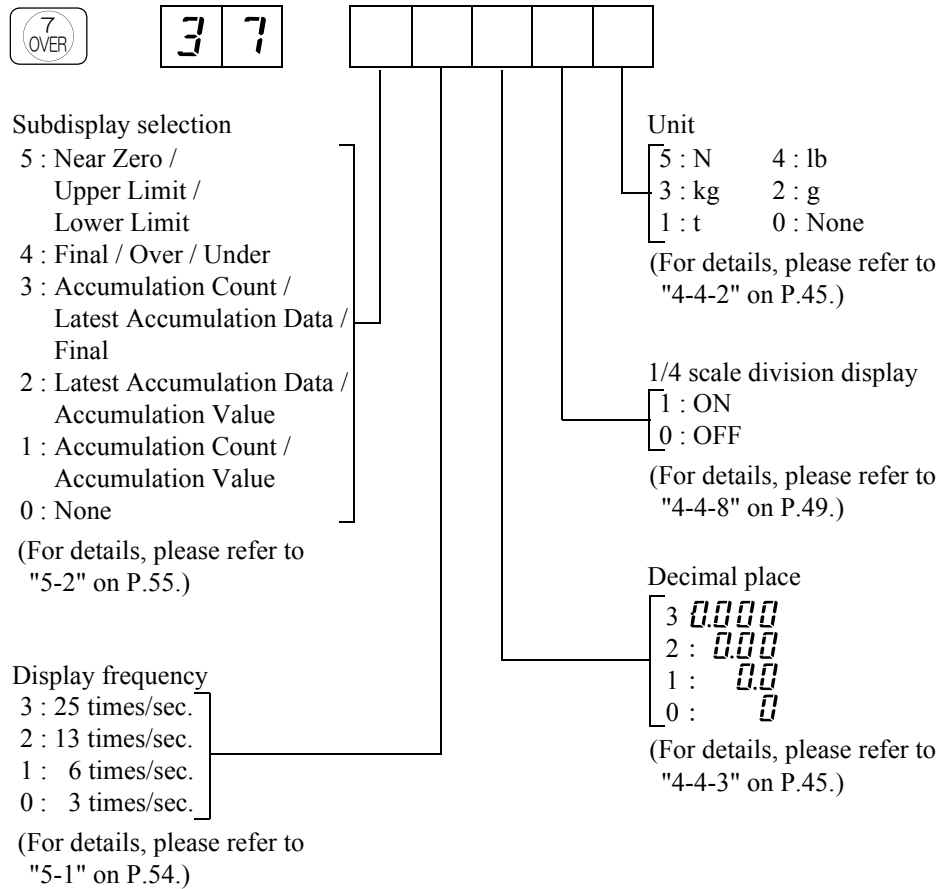

Request

When using the F701-C for any balance weight to undergo type approval by the Measurement Law, set the 1/4 scale division display to OFF. If it is set to OFF, the "zero point" lights only at a true zero point ($0 \pm 1/4$ scale division).

• **Gravitational Acceleration (Area number input)**



(For details, please refer to "4-4-7" on P.47.)

• **Gravitational Acceleration (Acceleration input)**

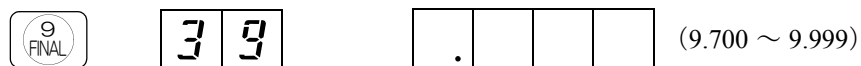

(For details, please refer to "4-4-7" on P.47.)

3-2-5. Setting Mode 4

In setting mode 4, setting values relating to communication are to be set.

• D/A Output Mode

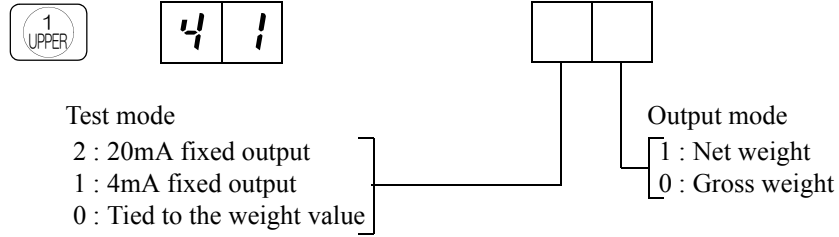

(For details, please refer to "10-4-3" on P.141.)

• D/A Zero Output Weight



(For details, please refer to "10-4-3" on P.141.)

• D/A Full Scale



(For details, please refer to "10-4-3" on P.141.)

• RS-485 I/F

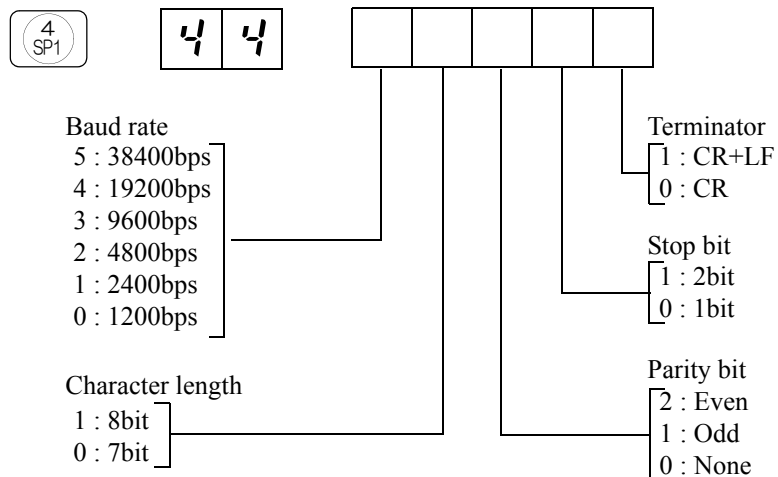

(For details, please refer to "10-5-3" on P.145.)

• ID Number

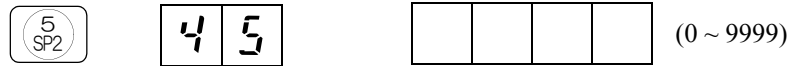

(For details, please refer to "10-5-4" on P.146.)

• RS-232C I/F

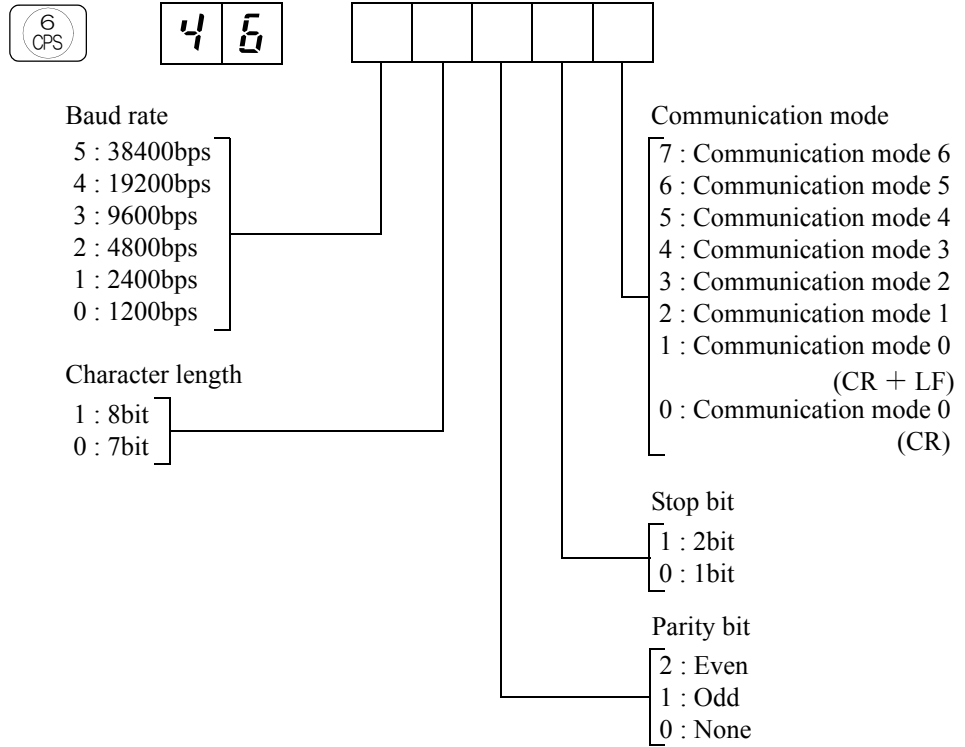

(For details, please refer to "10-2-3" on P.124.)

• External Function Selection

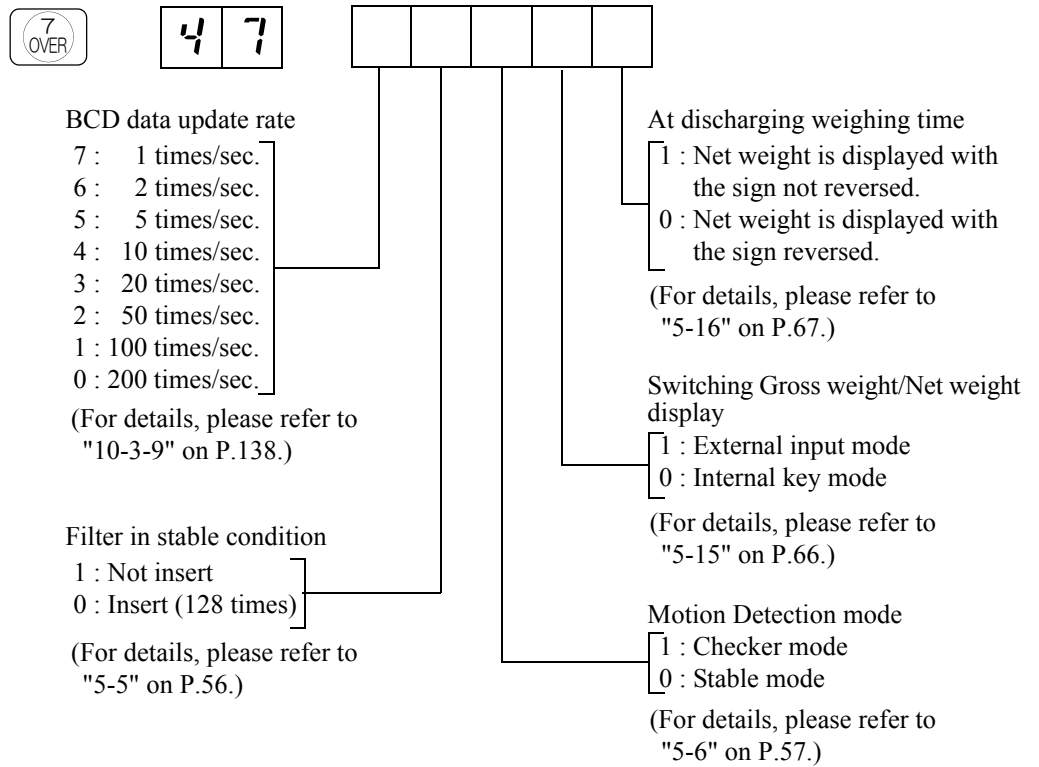

• Setting Value LOCK

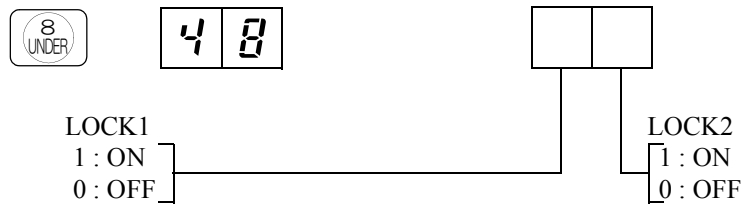

(For details, please refer to "8-1" on P.107.)

• Restriction on the Tare Subtraction Function

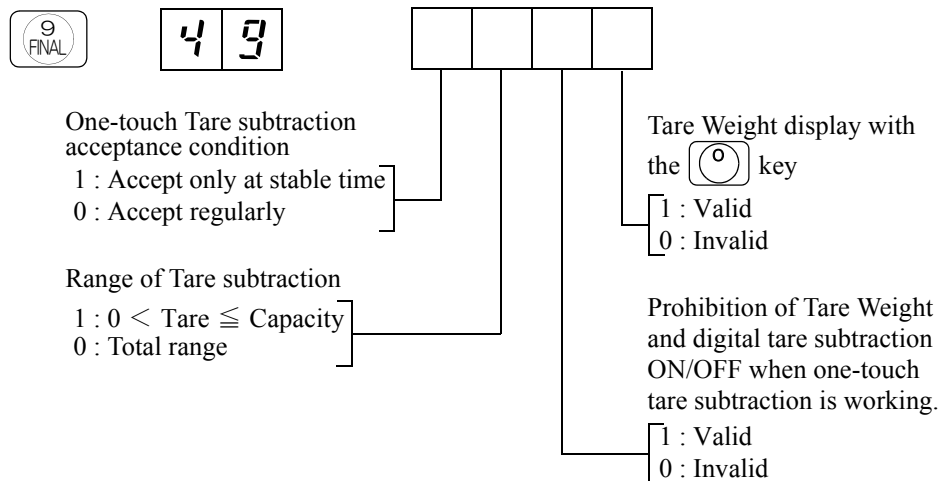

(For details, please refer to "5-14" on P.65.)

3-2-6. Setting Mode 5

• Input Selection

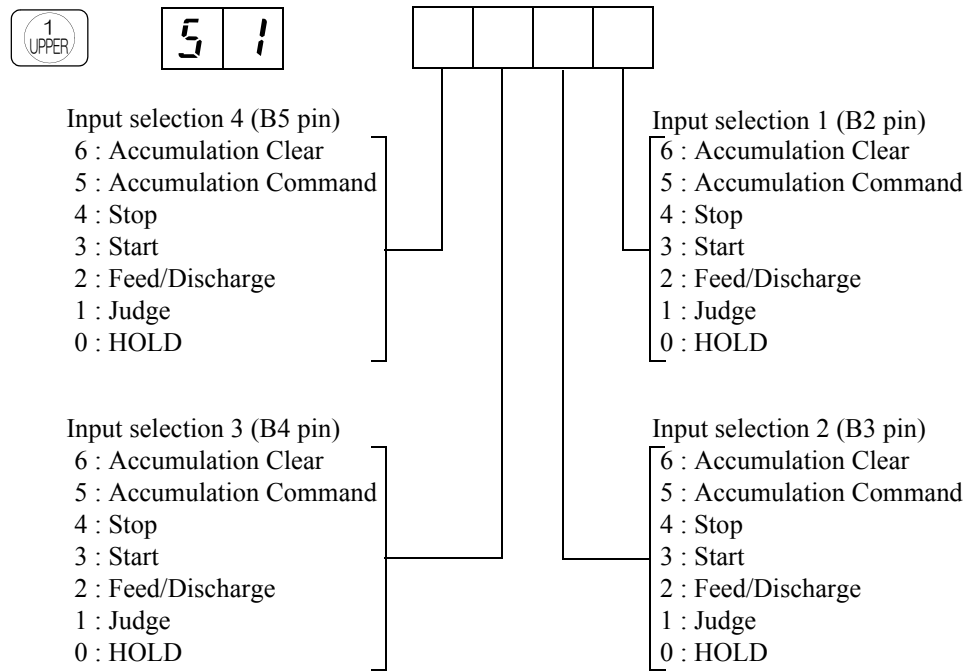

(For details, please refer to "9-4-11" on P.115.)

• Output Selection

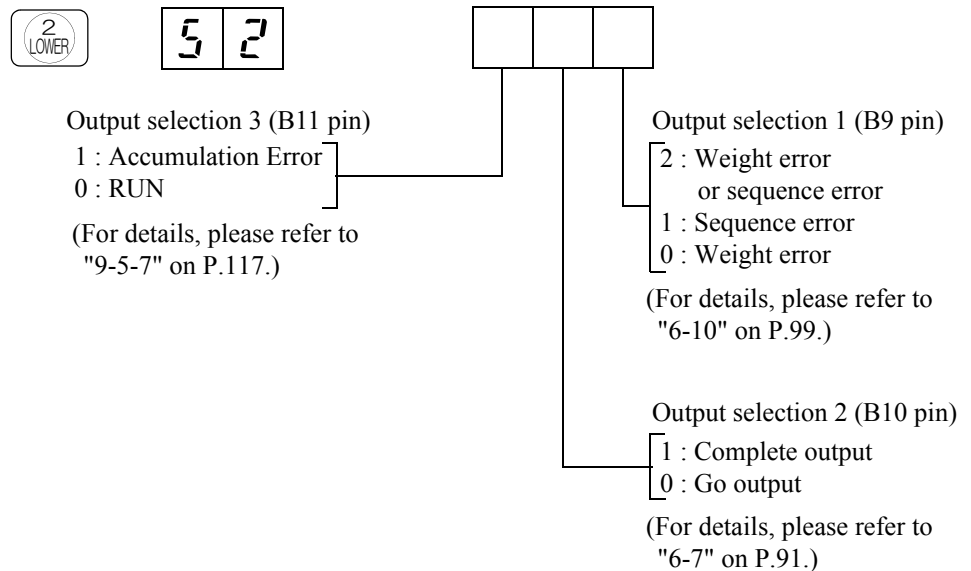

• CC-Link I/F Number of occupied station & Transmission speed

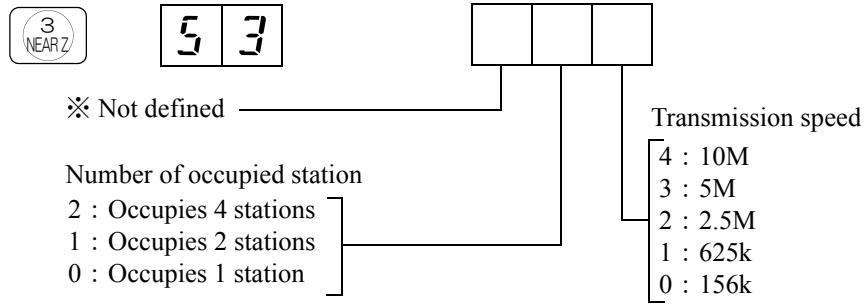

• CC-Link I/F Station No.



3-2-7. Setting Mode 8

In setting mode 8, statistical data having been accumulated in the F701-C is displayed, including Average Weight, Max. Value, Min. Value, General Standard Deviation, Sample Standard Deviation, Accumulation Count, Latest Accumulation Data, Max. - Min.

• **Average Weight**



 (0 ~ 99999)

• **Max. Value**



 (0 ~ 99999)

• **Min. Value**



 (0 ~ 99999)

• **General Standard Deviation**



 (0 ~ 99999)

• **Sample Standard Deviation**





 (0 ~ 99999)

• **Accumulation Count (n)**



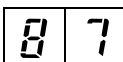
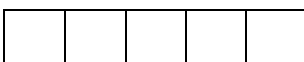

 (0 ~ 10000)

• **Latest Accumulation Data**

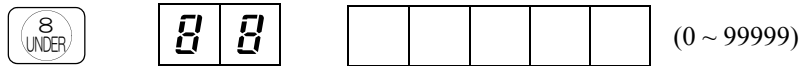

 (0 ~ 99999)

• Max. - Min. (R)

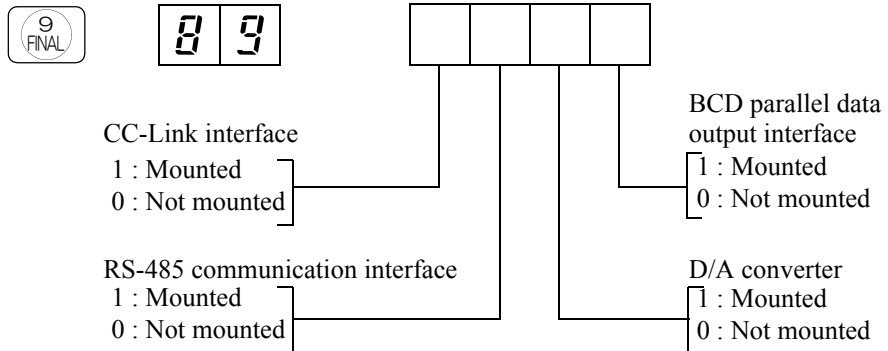

• Optional Board



● Calculation Formula

n = accumulation count = count of data

$\sum \chi$ = accumulation = total amount

$\bar{\chi}$ = average = accumulation / number of times = $\sum \chi / n$

General Standard Deviation

$$\sigma_n = \sqrt{\frac{\sum_{i=1}^n (\chi_i - \bar{\chi})^2}{n}}$$

Use all the data of the finite population and find the standard deviation of the population.

Sample Standard Deviation

$$\sigma_{n-1} = \sqrt{\frac{\sum_{i=1}^n (\chi_i - \bar{\chi})^2}{n - 1}}$$

Use the sample data among the population and the standard deviation of the population.



Data taking conditions

- When auto free fall compensation is OFF:
Data is taken when judgment is made.
 - When auto free fall compensation is ON:
Data is taken when free fall compensation is made.
(Weighing Function 3 in setting mode 2)
 - When the number of Judging Times is 00: No data is taken.
(Judging Time in setting mode 1)
- ※ For judgment and auto free fall compensation, refer to "a) Judging Times" on P.94.

【Example】

Times (n)	Accumu- lation	Actual weighing value	Average	Max.	Min.	Max. - Min.	General S.D.	Sample S.D.
(Latest Accumulation Data)								
0	0.000	0.000	0.000	0.000	0.000	0.000	error	error
1	20.050	20.050	20.050	20.050	20.050	0.000	0.000	error
2	40.090	20.040	20.045	20.050	20.040	0.010	0.005	0.007
3	60.160	20.070	20.053	20.070	20.040	0.030	0.012	0.015
4	80.240	20.080	20.060	20.080	20.040	0.040	0.016	0.018
5	100.260	20.020	20.052	20.080	20.020	0.060	0.021	0.024
6	120.260	20.000	20.043	20.080	20.000	0.080	0.027	0.030
7	140.270	20.010	20.039	20.080	20.000	0.080	0.028	0.030
8	160.250	19.980	20.031	20.080	19.980	0.100	0.033	0.035
9	180.360	20.110	20.040	20.110	19.980	0.130	0.039	0.042
10	200.370	20.010	20.037	20.110	19.980	0.130	0.038	0.041

← Accumulation clear



Statistical data is cleared by inputting the password "1235".
(Please refer to "7-3.Accumulation Clear" on P.103.)

4. CALIBRATION

4-1. Span Calibration

Calibration is performed for matching the F701-C to a load cell. For example, it is work to adjust so that the F701-C accurately displays 100.00kg when an actual load (or weight) of 100kg is applied to the load cell (balance section) of the weighing apparatus to which the F701-C is connected. This operation is called Span Calibration.

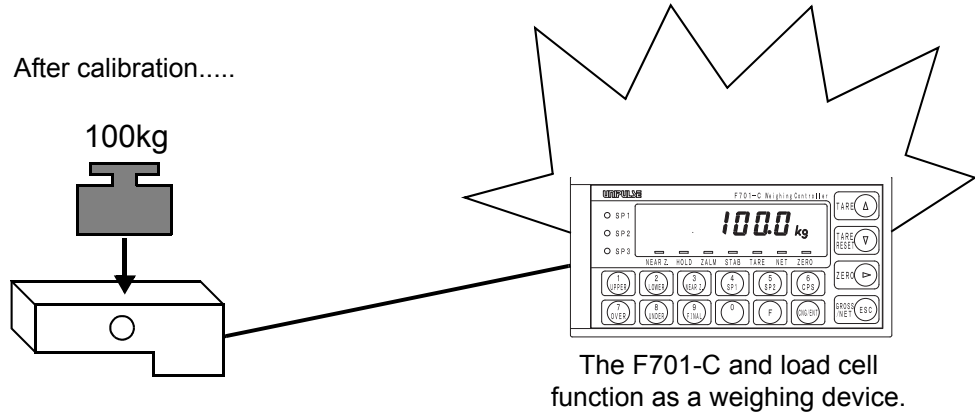
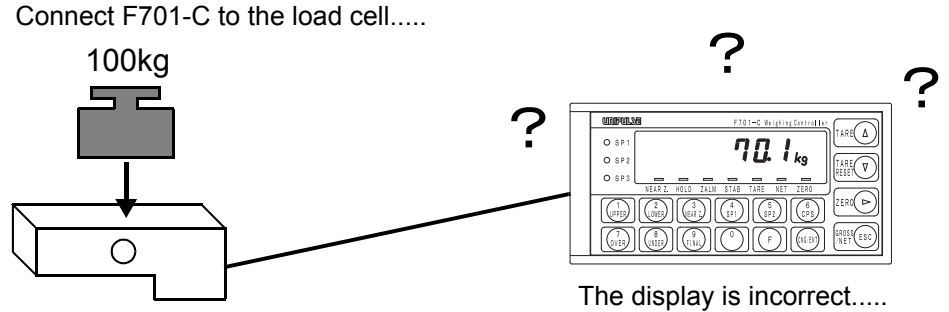

4-2. Span Calibration Procedure

Follow the steps below to perform Span Calibration.

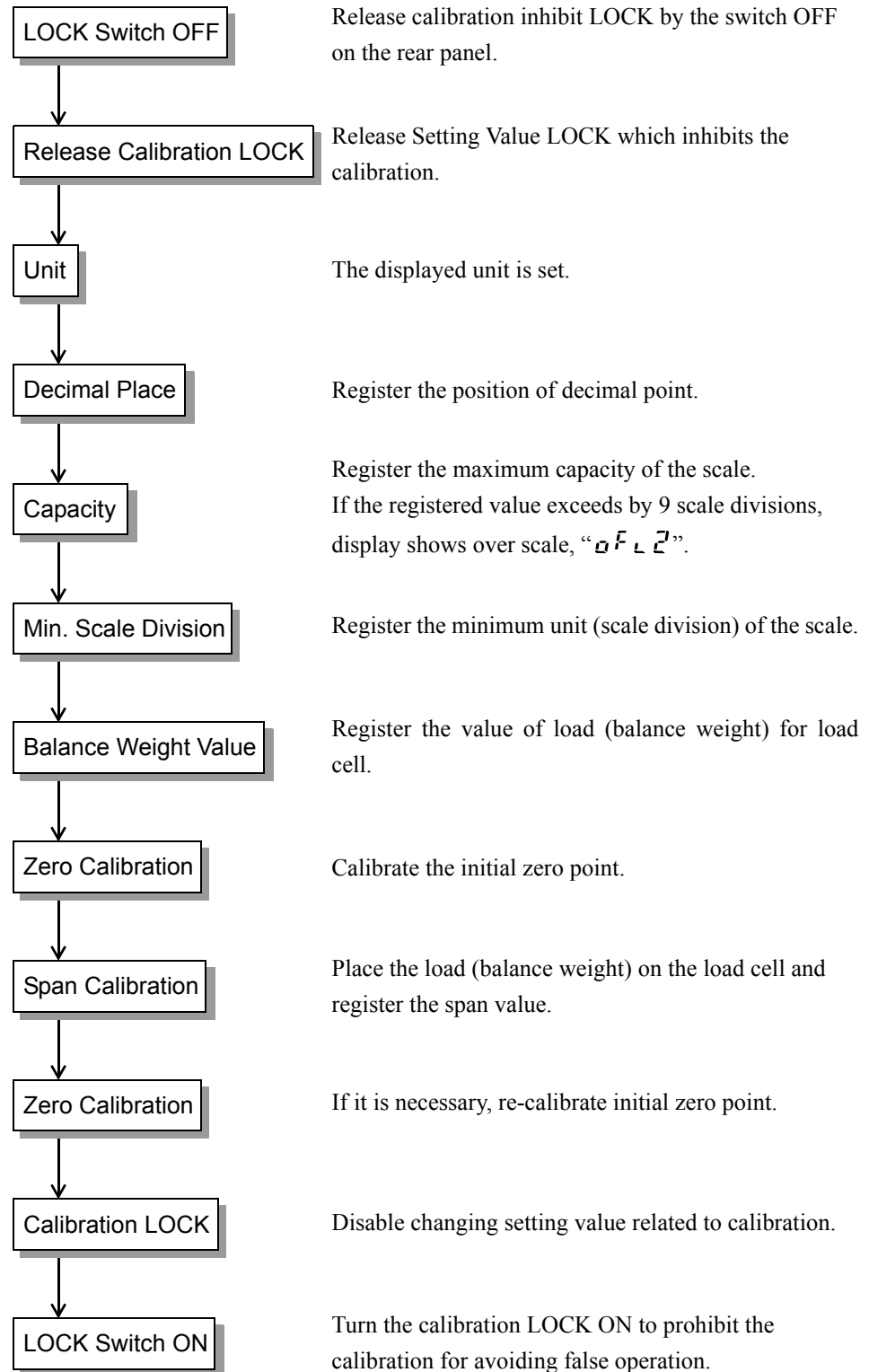

4-3. Secondary Calibration Procedure (Equivalent Calibration)

Calibration procedure performed by entering the rated output value (mV/V) and rated capacity value of load cell without using real load.

Secondary calibration function is provided for provisional calibration when the F701-C develops trouble or the calibration value is mistakenly changed.

The secondary calibration is only a provisional method. Calibration with actual load must be done as soon as possible.

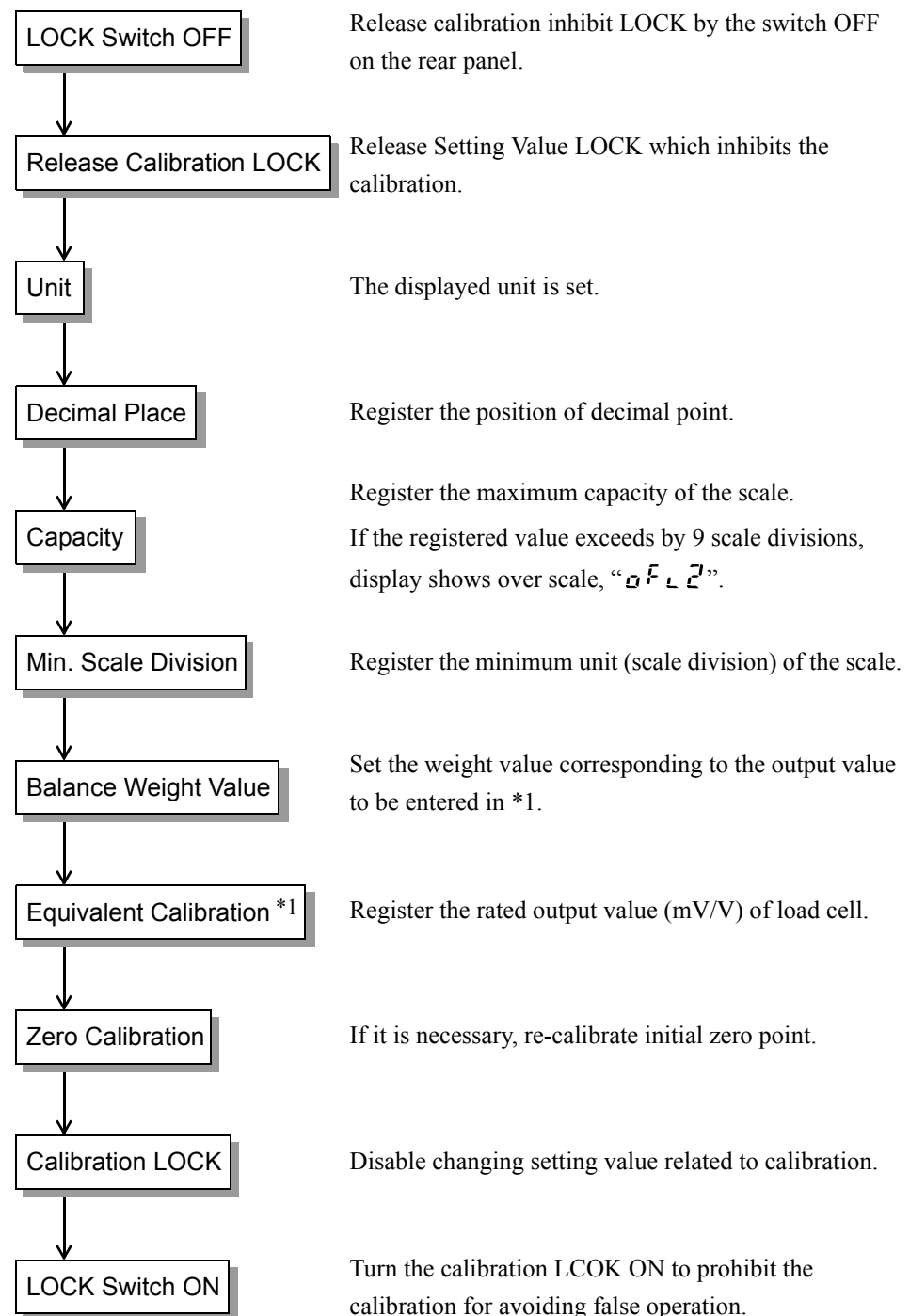

Request

- Set the Balance Weight Value to the Capacity or less.
- For performing calibration at the rated value according to the specifications of the load cell, set the Capacity to the same value as the rated value of the load cell.
- When connecting several load cells in parallel, it is possible to occur some differences between input and output value due to voltage drop caused by connection or material of lines.
In this case, register actual input value to perform accurate calibration.

4-4. Preparation for Calibration

4-4-1. LOCK Release

F701-C features a LOCK function for disabling changes in calibration and setting values. The software LOCK is performed with the operation on the display; the hardware LOCK is located on rear panel. Release both of locks when the calibration is performed.

Operation

- 1) LOCK OFF on the rear panel.

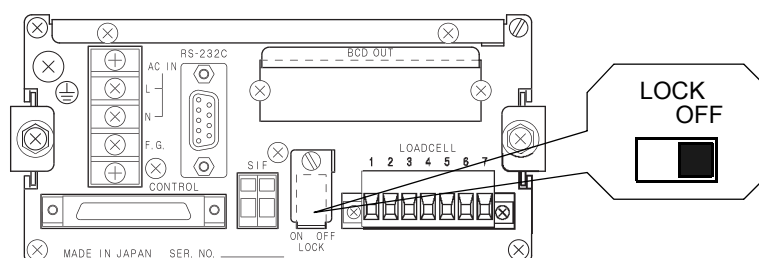

- 2) Select setting mode 4.

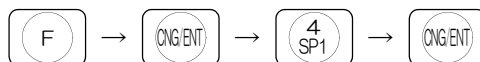

- 3) Set LOCK2 to OFF. (8-Setting Value LOCK)

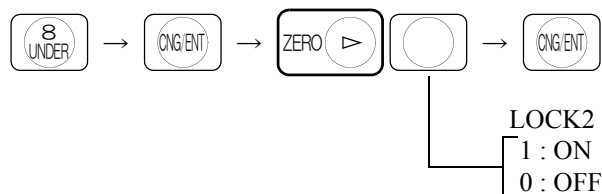

LOCK is released through above procedure. After the calibration is finished, LOCK ON to protect the calibration value.



Concerning LOCK and setting values to be protected, refer to "18.THE LIST OF INITIAL SETTING VALUE" on P.173.

4-4-2. Unit

Register the unit of the scale. The unit can select from t, kg, g, N, lb or None.

Operation

1) Select setting mode 3.

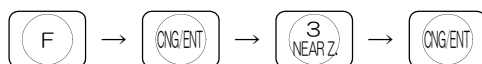

2) Select Unit. (7-Function Selection)

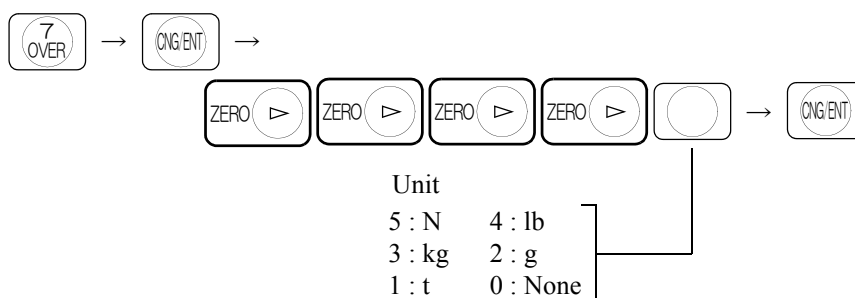

4-4-3. Decimal Place

Set the decimal place for weight-related displays, setting items, etc. Decimal place should be selected from 0, 0.0, 0.00 or 0.000. This selection results in a common decimal place.

Operation

1) Select setting mode 3.

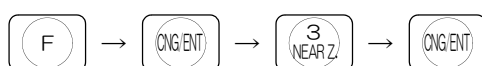

2) Select a desired decimal place. (7-Function Selection)

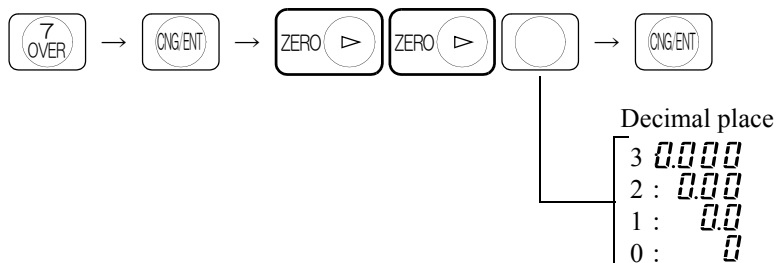

In the F701-C, the decimal place is all fixed except for weight-related descriptions.

※ It cannot be changed.

4-4-4. Capacity

Register the maximum capacity of the scale. If the registered value exceeds by 9 scale divisions, display shows over scale, “ $\square F \square Z$ ”. (Input range / 0 ~ 99999)

Operation

1) Select setting mode 3.

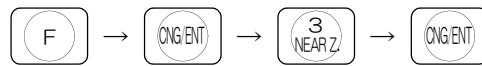

2) Input the Capacity. (2-Capacity)

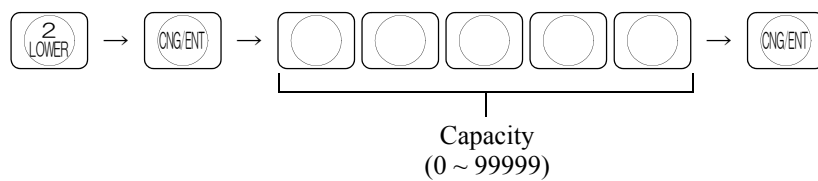

4-4-5. Minimum Scale Division

Register the minimum unit (scale division) of the scale. (Input range / 1 ~ 100)

Operation

1) Select setting mode 3.

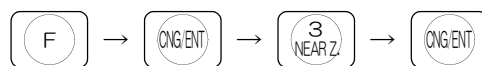

2) Input the Min. Scale Division. (3-Min. Scale Division)

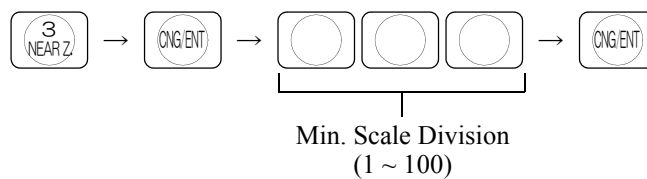

4-4-6. Balance Weight Value

Register the value of load (balance weight) before the Span Calibration.
 (Input range / 0 ~ 99999)

Operation

1) Select setting mode 3.

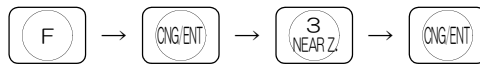

2) Input the Balance Weight Value. (1-Balance Weight Value)

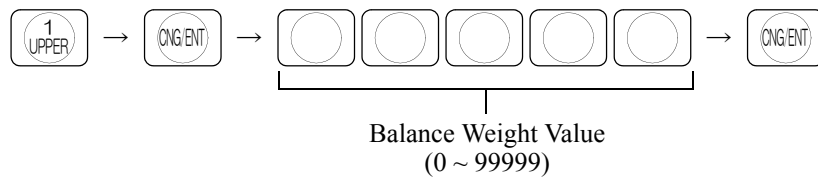

4-4-7. Gravitational Acceleration

If the calibration location and installation location of the balance are different, correct the gravitational error resulting from an area-to-area difference in gravitational acceleration by this function.

If the calibration location and installation location are in the same area, this setting is not needed.

Find the area number (01 ~ 16) of the area where actual load calibration is carried out from the Gravitational Acceleration correction table on the next page, set the number, and then perform actual load calibration.

Next, find the actual installation area from the table, and input the area number. Now, the difference from the calibration location in gravitational acceleration is corrected.

Also, if the area number is set at 00, Gravitational Acceleration (acceleration input) becomes valid.

Operation

1) Select setting mode 3.

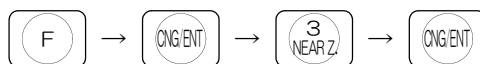

2) Input the Area number. (8-Gravitational Acceleration : area number input)

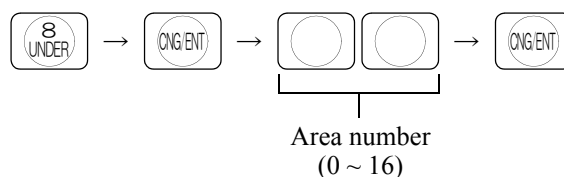

3) If the Area number is set at 00, input Acceleration.

(9-Gravitational Acceleration : acceleration input)

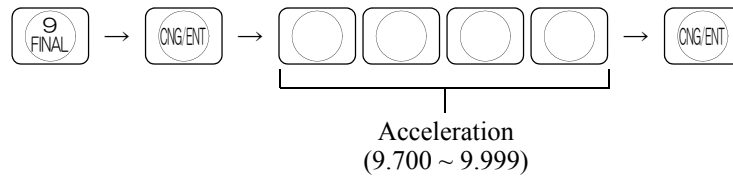

If the area number is set at 00, Gravitational Acceleration (Acceleration input) becomes valid.

Gravitational acceleration correction table

01	9.806	02	9.805	03	9.804	04	9.803
05	9.802	06	9.801	07	9.800	08	9.799
09	9.798	10	9.797	11	9.796	12	9.795
13	9.794	14	9.793	15	9.792	16	9.791



Amsterdam	9.813m/s ²	Ottawa	9.806m/s ²
Athens	9.800m/s ²	Paris	9.809m/s ²
Auckland NZ	9.799m/s ²	Rio de janeiro	9.788m/s ²
Bangkok	9.783m/s ²	Rome	9.803m/s ²
Birmingham	9.813m/s ²	San Francisco	9.800m/s ²
Brusseles	9.811m/s ²	Singapore	9.781m/s ²
Buenos Aires	9.797m/s ²	Stockholm	9.818m/s ²
Calcutta	9.788m/s ²	Sydney	9.797m/s ²
Capetown	9.796m/s ²	Taichung	9.789m/s ²
Chicago	9.803m/s ²	Tainan	9.788m/s ²
Copenhagen	9.815m/s ²	Taipei	9.790m/s ²
Cyprus	9.797m/s ²	Tokyo	9.798m/s ²
Djakarta	9.781m/s ²	Vancouver,BC	9.809m/s ²
Frankfurt	9.810m/s ²	Washinton DC	9.801m/s ²
Glasgow	9.816m/s ²	Wellington NZ	9.803m/s ²
Havana	9.788m/s ²	Zurich	9.807m/s ²
Helsinki	9.819m/s ²		
Kuwait	9.793m/s ²		
Lisbon	9.801m/s ²		
London (Greenwich)	9.812m/s ²		
Los Angelse	9.796m/s ²		
Madrid	9.800m/s ²		
Manila	9.784m/s ²		
Melbourne	9.800m/s ²		
Mexico City	9.779m/s ²		
Milan	9.806m/s ²		
New York	9.802m/s ²		
Oslo	9.819m/s ²		

4-4-8. 1/4 Scale Division

It divides the minimum scale division into four (4) parts. The “ZERO” (center zero) lamp turns on when the weight is between +1/4 division and -1/4 division.

1/4 scale division selects ON/OFF.

Operation

1) Select setting mode 3.

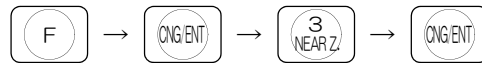

2) Select 1/4 scale division display ON/OFF. (7-Function Selection)

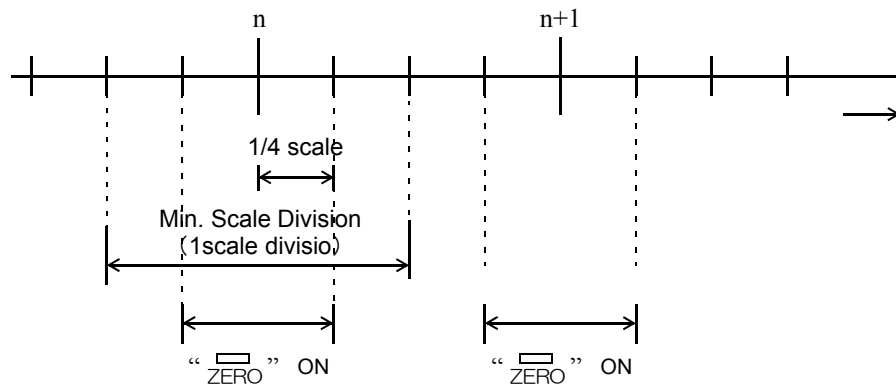
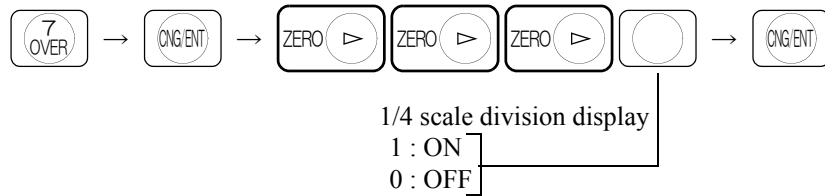

When the 1/4 scale division setting is OFF, “ZERO” lamp only works at the zero point.

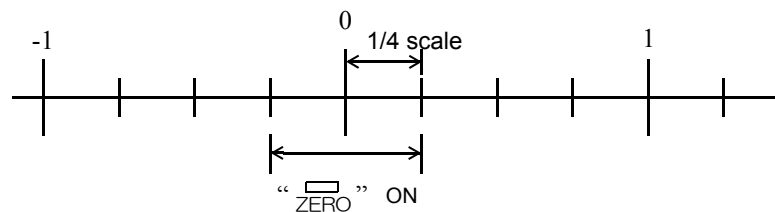

4-5. Zero Calibration

Register initial zero point.

- Verify there are no excess loads applied to load cell (or scale).
- Check that “ $\overline{\text{STAB}}$ ” is ON.
(Correct calibration can not be completed if signal is unstable.)

Operation

1) Select setting mode 9 (Calibration mode).

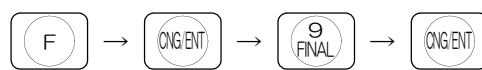

2) Register the Zero point.

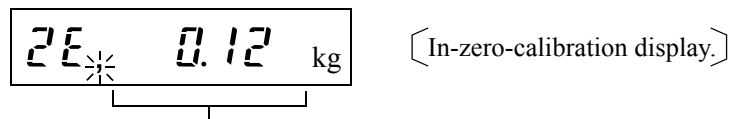
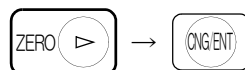

The in-calibration display differs according to the pre-calibration condition.

3) When the weight value display becomes 0, Zero Calibration is completed.

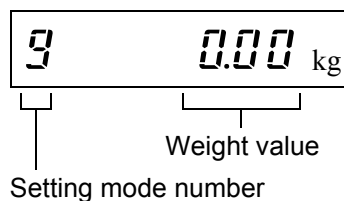

If a calibration error is displayed, redo Zero Calibration corresponding to the following error messages. (Please refer to "11.OVER SCALE & ERROR" on P.155.)

- “ $\overline{\text{E r r 2}}$ ”

Initial dead load is above zero adjustment range.

Remove any excess load from load cell or scale. If $\overline{\text{E r 2}}$ is still displayed, connect a resistor between +EXC and -SIG load cell connections. This should shift the zero point.



- This table is for a 350 Ω load cell.
- The temperature coefficient of the connected resistor directly influences the accuracy of the indicator. Use a resistance having a temperature coefficient of 50ppm/°C or more (recommended value of about 5ppm/°C).

Resistance		Strain	
Calculated value	Approx.value	μ -STRAIN	mV/V
875 k Ω	866 k Ω	200	0.1
437 k Ω	442 k Ω	400	0.2
291 k Ω	294 k Ω	600	0.3
219 k Ω	221 k Ω	800	0.4
175 k Ω	174 k Ω	1000	0.5
146 k Ω	147 k Ω	1200	0.6
125 k Ω	124 k Ω	1400	0.7
109 k Ω	110 k Ω	1600	0.8
97 k Ω	97.6 k Ω	1800	0.9
87.3 k Ω	86.6 k Ω	2000	1.0
79.4 k Ω	78.7 k Ω	2200	1.1
72.7 k Ω	73.2 k Ω	2400	1.2
67.1 k Ω	66.5 k Ω	2600	1.3
62.3 k Ω	61.9 k Ω	2800	1.4
58.2 k Ω	57.6 k Ω	3000	1.5
54.5 k Ω	54.9 k Ω	3200	1.6
51.3 k Ω	51.1 k Ω	3400	1.7
48.4 k Ω	48.7 k Ω	3600	1.8
45.9 k Ω	46.4 k Ω	3800	1.9
43.6 k Ω	43.2 k Ω	4000	2.0
41.5 k Ω	41.2 k Ω	4200	2.1
39.6 k Ω	39.2 k Ω	4400	2.2
37.9 k Ω	38.3 k Ω	4600	2.3
36.3 k Ω	36.5 k Ω	4800	2.4
34.8 k Ω	34.8 k Ω	5000	2.5

• “ $\epsilon \bar{E} r r \bar{E}$ ”

Initial dead load is negative.

Check that load cell is mounted in the correct direction; check that load is being applied to the load cell in the correct direction; check that the +SIG and -SIG lines are properly connected.

If $\epsilon \bar{E} r r \bar{E}$ still displayed, connect a resistor between -EXC and -SIG load cell connections. This should shift the zero point. Do Zero Calibration again.

4-6. Span Calibration

Span Calibration means putting a load (test weight) on the load cell (or scale) and calibrating so the F701-C indicates correct weight.

- Put the Balance Weight Value which is set the Balance Weight Value, on the load cell (or scale).
(Calibrating with more than 50% of the Capacity is favorable in respect of linearity.)
- Verify there are no excess loads applied to load cell (or scale).
- Check that “ $\overline{\text{STAB}}$ ” is on.
(Correct calibration can not be completed if signal is unstable.)

Operation

- 1) Select setting mode 9 (Calibration mode).

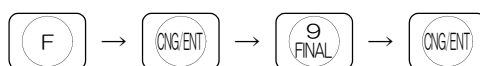

- 2) Perform Span Calibration. (1-Span Calibration)

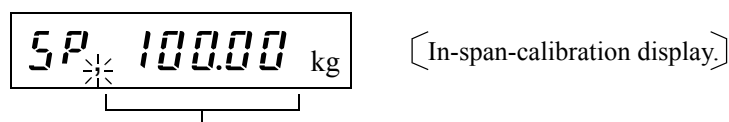
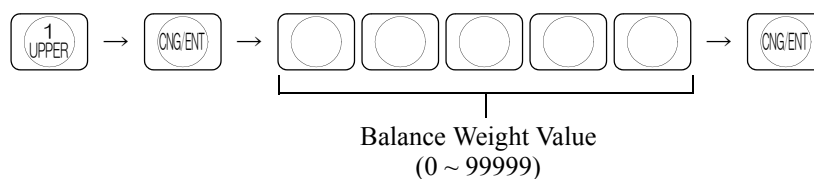

The in-calibration display differs according to the pre-calibration condition.
(The previous setting value, etc., is displayed.)

- 3) When the weight value display becomes equal to the Balance Weight Value, Span Calibration is completed.

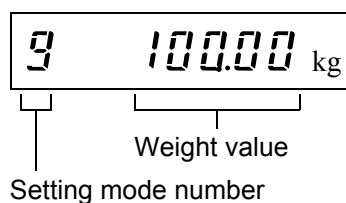

※ If any error message appears, refer to "11.OVER SCALE & ERROR" on P.155.

4-7. Secondary Calibration (Equivalent Calibration)

By key-inputting the weight value corresponding to the output value (mV/V) of the load cell, calibration is performed so that the input of the entered output value results in the entered weight value display.

Operation

1) Select setting mode 3.

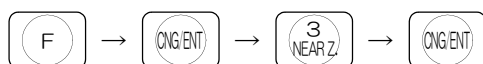

2) Input the Balance Weight Value corresponding to the output value to be entered in 4).
(1-Balance Weight Value)

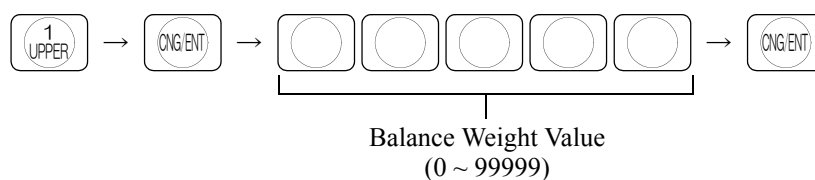

3) Select setting mode 9.

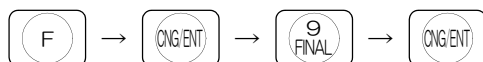

4) Input the Output value of the load cell. (2-Equivalent Calibration)

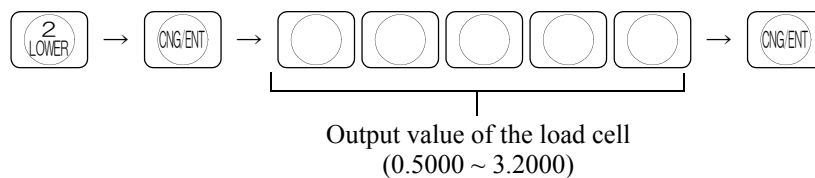

※ If any error message appears, refer to "11.OVER SCALE & ERROR" on P.155.

※ If “ $\bar{E} r r l$ ” (Zero Calibration again) appears, redo Zero Calibration, and then perform Equivalent Calibration again.

※ “ $\bar{E} r r \bar{E}$ ” is displayed when calibrating by resolution that exceeds 1/10000.

5. FUNCTION SETTINGS

5-1. Display Frequency

Select the F701-C display frequency. The numbers of updates on the display per second is only selected here.

Internal A/D conversion speed and CPU processing speed are not changed. The available display frequencies are: 25, 13, 6 or 3 times/sec.. 25 times/sec. is recommended for normal operation.

If the display flickers, select a lower frequency.

Operation

1) Select setting mode 3.

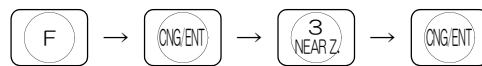

2) Select Display frequency. (7-Function Selection)

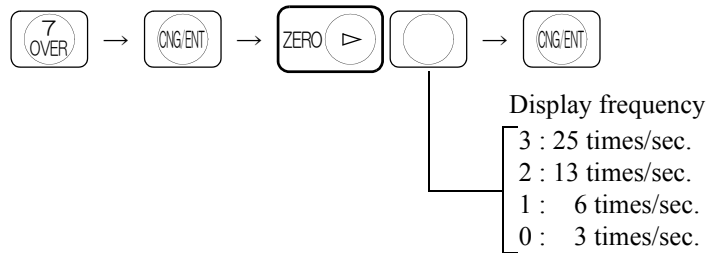

5-2. Subdisplay Selection

Set the data to be displayed in the subdisplay area.

What is displayed in the subdisplay area is the data set here out of:

Near Zero/Upper Limit/Lower Limit; Final/Over/Under; Accumulation Count/Latest Accumulation Data/Final; Latest Accumulation Data/Accumulation Value; Accumulation Count/Accumulation Value; and None.

(For details, please refer to "1-1.Front Panel" ② Subdisplay on P.1.)

Operation

1) Select setting mode 3.

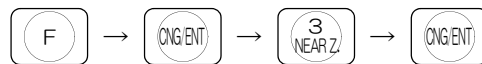

2) Select the data to be displayed. (7-Function Selection)

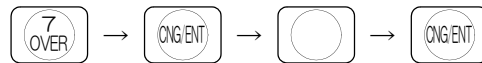

Subdisplay selection

- 5 : Near Zero / Upper Limit / Lower Limit
- 4 : Final / Over / Under
- 3 : Accumulation Count / Latest Accumulation Data / Final
- 2 : Latest Accumulation Data / Accumulation Value
- 1 : Accumulation Count / Accumulation Value
- 0 : None

5-3. Digital Filter

This function minimizes instability of the weight value by calculating the average frequency of the data converted from analog to digital. The frequency of the moving average selected from OFF(0) ~ 256 times. A higher frequency will make a more stable display with slower response.

A lower frequency will have quicker response but more unstable display.

Select the most suitable value for the weighing.

Operation

1) Select setting mode 2.

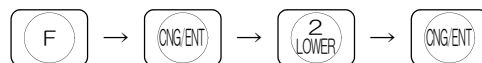

2) Input the frequency of moving averages. (6-Digital Filter)

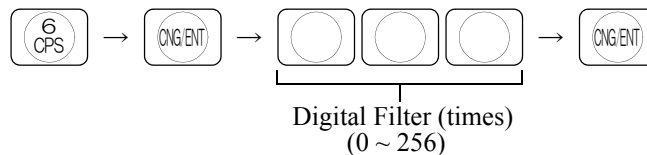

5-4. Analog Filter

This function stabilizes the display by removing low frequency noise from the load cell signal as well as averaging analog signals.

Selectable frequencies are: 2, 4, 6 or 8Hz. A higher frequency will make a more quick response but sometimes read a noise in.

Select the most suitable value for the weighing.

Operation

1) Select setting mode 1.

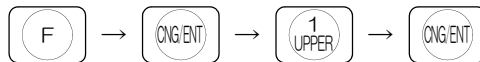

2) Select cutoff frequency. (8-Analog Filter)

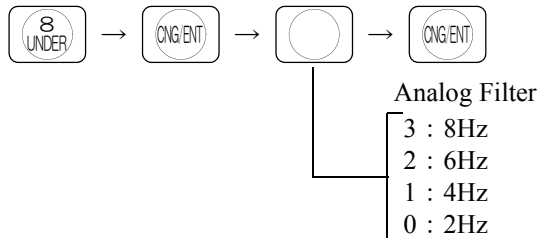

5-5. Filter in Stable Condition

When indicated value is stable, this function automatically insert the Digital Filter for restraining the instability. Select whether inserts it or not.

Regarding the definition of stability, refer to "5-6.Motion Detection (MD)" on P.57.

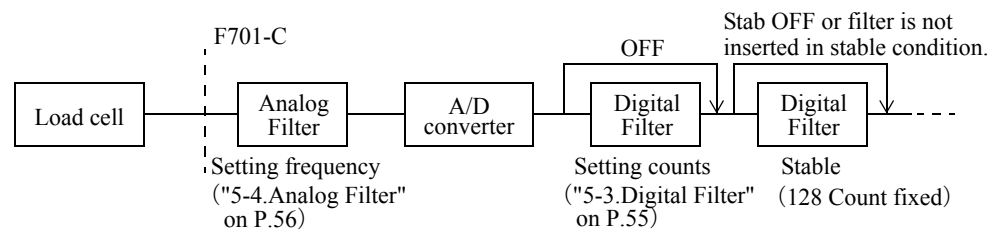

Operation

1) Select setting mode 4.

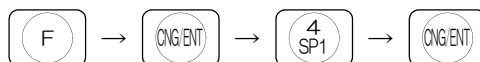

2) Select whether or not to insert the filter. (7-External Function Selection)

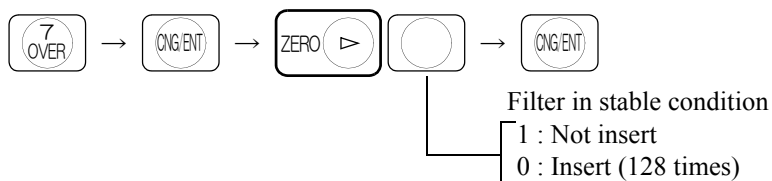

5-6. Motion Detection (MD)

Set the parameter to detect the stability of the indicated value.

When the range of weight changes is within the set range and the status lasts for set period of time, the Stab. turns ON considering to be the weight stable.

There are stable mode and checker mode in Motion Detection.

Stable mode

D1 ~ D5 shown below are compared with a set range at each A/D conversion.

- * D1 represents the difference between current weight value and the value 1 second previous. If one of them exceeds the range, the Stab. turns OFF at once.

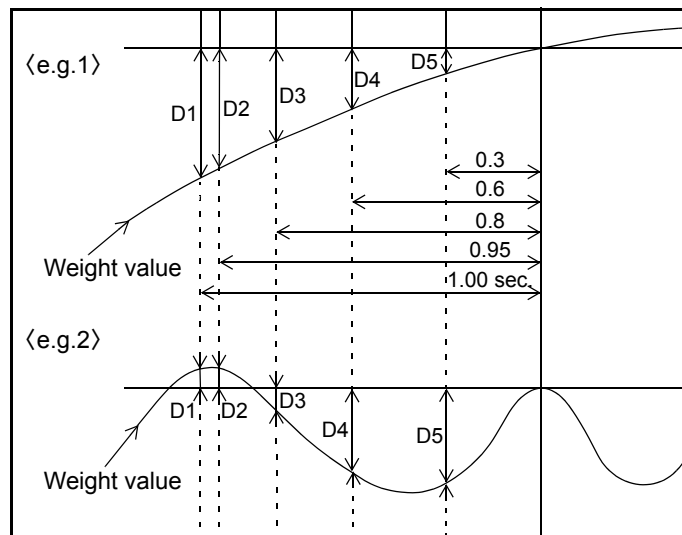

Checker mode

D1 ~ D3 shown below are compared with a set range at each A/D conversion.

If one of them exceeds the range, the Stab. turns OFF at once.

- * D1 represents the difference between current weight value and the value 0.09 second previous.

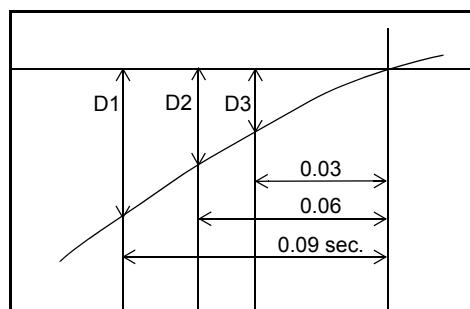

When the Stab. is ON, it enables to insert the Digital Filter to restrain the instability of weight value. (Please refer to "5-5.Filter in Stable Condition" on P.56.)

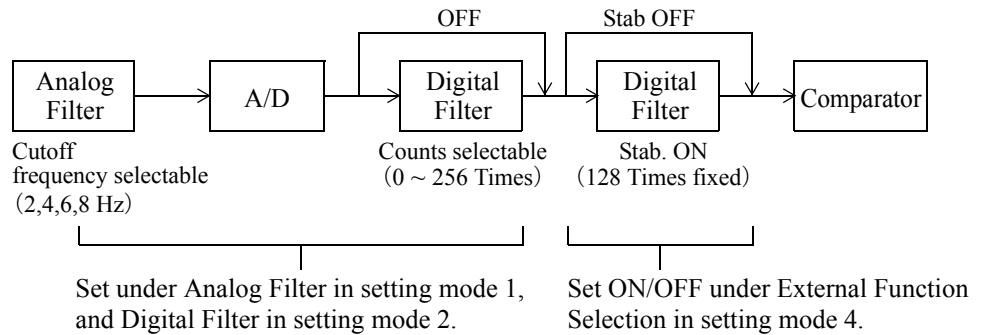

Setting motion detect parameter

MD mode Select the stable condition from stable mode or checker mode.

Operation

1) Select setting mode 4.

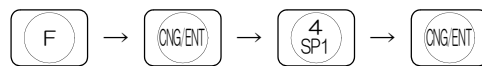

2) Select a desired mode. (7-External Function Selection)

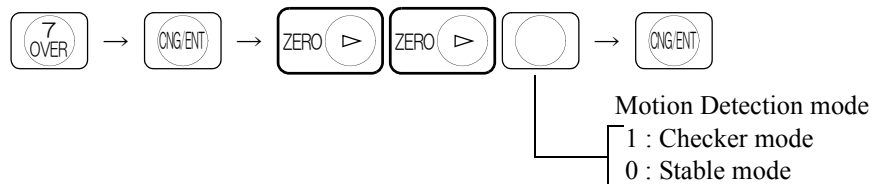

MD period Setting the period for judging the stability of weight.
(Input range / 0.0 ~ 9.9)

MD range Comparing the value (setting value × minimum scale division) with the range of weight change.
(Input range / 0 ~ 99)

Operation

1) Select setting mode 2.

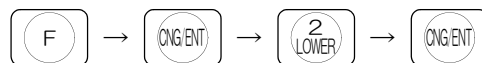

2) Input the Period and Range. (7-Motion Detection)

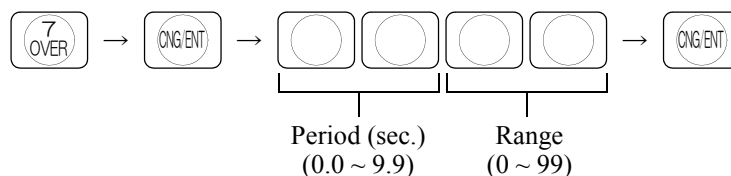

5-7. Zero Tracking (ZT)

This function automatically adjusts slow drifts and slight shifting of the zero point due to small amounts of accumulation on a scale.

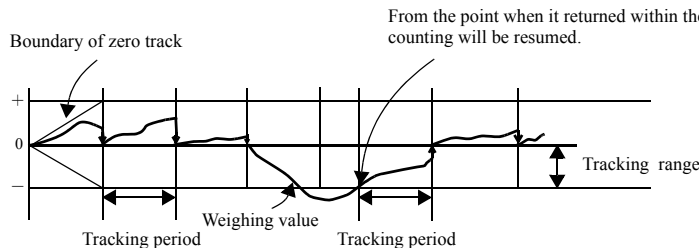

• Zero Tracking adjusts the zero point every set period when the shifting of the zero point is within the set point.

• The Tracking Period must be set between 0.0 and 9.9 seconds. The Tracking Range (digit) must be set from 0 ~ 9999 using a 1/4 scale division as a unit. (0002=0.5 divisions, 0012=3 divisions)
Zero Tracking does not work when the period is set 0.0 or the range is set to 00.

Boundary of zero track

From the point when it returned within the range, counting will be resumed.

Tracking period

Weighing value

Tracking range

a) Zero Tracking Period (Input range / 0.0 ~ 9.9)

b) Zero Tracking Range (Input range / 0 ~ 9999)

Operation

a)

1) Select setting mode 2.

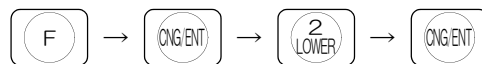

2) Input the Zero Tracking Period. (8-Zero Tracking Period)

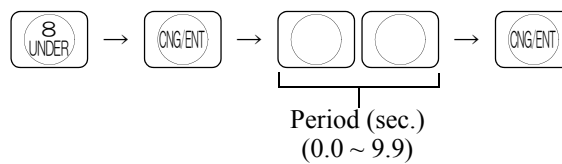

b)

1) Select setting mode 2.

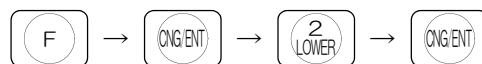

2) Input the Zero Tracking Range. (9-Zero Tracking Range)

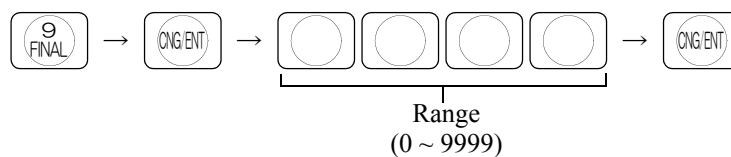

5-8. Digital Zero (DZ)

The Gross weight is forcibly zeroed by this function. The Net weight changes according to the following expression: (Net weight) = (Gross weight) - (Tare weight).

If the digital zero operation is performed where Gross weight exceeds the DZ Regulation Value (Please refer to "5-10.Zero Regulation Value" on P.61.), "Z_{ALM}" flashes to give a warning of the problem.

In this case DZ Regulation Value is subtracted from Gross weight.

Operation

1) Press  → .

2) Gross is zeroed.

• Digital zero by external signal

By short-circuiting A3pin (D/Z ON) and COM on the control connector, Gross weight is immediately zeroed.

Net weight changes according to the following expression:

(Net weight) = (Gross weight) - (Tare weight).

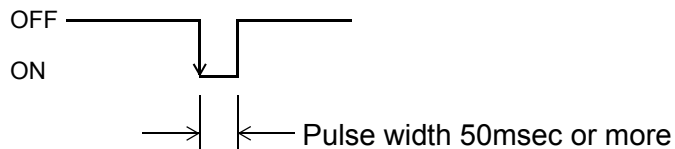

* In a case where 0 is not indicated when performing digital zero operation or when "Z_{ALM}" flashes, the following causes are considered.

Cause	Measure
Digital zero operation was performed when the DZ Regulation Value (default value 200) was exceeded.	<ul style="list-style-type: none"> • Change the set value of the DZ Regulation Value and perform digital zero operation again. (However, since this is a temporary measure, perform Zero Calibration at an early time.) • Remove lightweight residue adhered to the tank. • Check that there is no mechanical contact.

5-9. Digital Zero Clear

This function clears the digital zero.

If this operation is performed when “ $\overline{\text{ZALM}}$ ” flashes, the digital zero is cleared, and “ $\overline{\text{ZALM}}$ ” goes out.

Operation

1) By selecting setting mode 9 (Calibration mode), the digital zero is cleared.

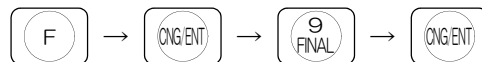

5-10. Zero Regulation Value

Set a range of zero point adjustment (a gap from the registered Zero Calibration value) by digital zero or zero tracking.

If the digital zero operation is performed or zero tracking operates where the DZ Regulation Value is exceeded, “ $\overline{\text{ZALM}}$ ” flashes to give a warning of the problem.

(Input range / 0 ~ 9999)

Operation

1) Select setting mode 3.

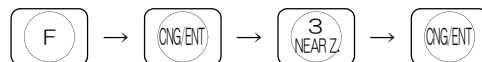

2) Input the DZ Regulation Value. (6-DZ Regulation Value)

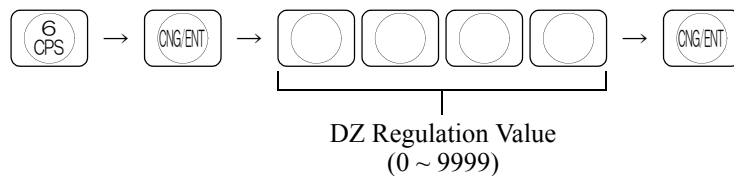

5-11. One-touch Tare Subtraction

Tare is subtracted and Net weight is zeroed by pressing  key.

However, the operation is performed only when “ $\overline{\text{STAB}}$ ” is on depending on the setting of Restriction on the Tare Subtraction Function in setting mode 4. The range of Tare subtraction can be selected from all range or $0 < \text{Tare} \leq \text{Capacity}$.

Operation

1) Press .

2) “ $\overline{\text{TARE}}$ ” lights.

• Tare subtraction by external signal

By short-circuiting A4pin (Tare subtraction ON) and COM on the control connector, Net weight is immediately zeroed, and “ $\overline{\text{TARE}}$ ” lights.

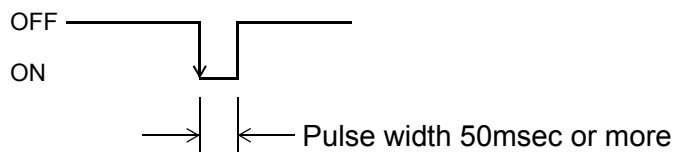

* If Net weight is not zeroed by performing the operation of Tare subtraction, the following causes are presumable.

Cause	Measure
The indicated value is Gross weight.	Press the  key to change the indicated value into Net weight. (If “ $\overline{\text{NET}}$ ” is on, the indicated value is Net weight.)
The indicated value is not stable. (By setting)	Perform the operation of Tare subtraction when “ $\overline{\text{STAB}}$ ” is ON.
The indicated value is out of the range of Tare subtraction. (By setting)	Perform the operation of Tare subtraction in the range of Tare subtraction.

5-12. One-touch Tare Subtraction Reset

The subtracted Tare can be restored and Net weight becomes equal to Gross weight.

Operation

1) Press .

2) “” goes out.

• Tare subtraction reset by external signal

By short-circuiting A5pin (Tare subtraction OFF) and COM on the control connector, Tare subtraction is immediately reset, and Net weight and Gross weight are equalized.

“” goes out.

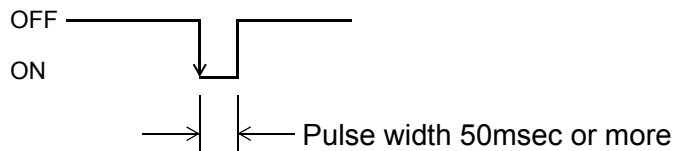

* If Net weight and Gross weight are not equalized by resetting Tare subtraction, the following cause is presumable.

Cause	Measure
The digital tare subtraction function is valid.	Set the value of Tare Weight in setting mode 1 to 0, or set digital tare subtraction ON/OFF in setting mode 2 to OFF.

5-13. Digital Tare Subtraction

Tare is subtracted and Net weight is zeroed.

Set Tare Weight by pressing  key then set digital tare subtraction ON.

a) Digital tare subtraction (Select from ON/OFF)

b) Tare Weight (Input range / 0 ~ 99999)

Operation

a)

1) Select setting mode 2.

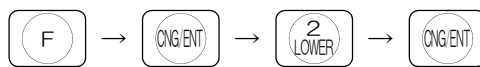

2) Select Digital tare subtraction ON/OFF. (3-Weighing Function 3)



1 : Digital tare subtraction ON
0 : Digital tare subtraction OFF

b)

1) Select setting mode 1.

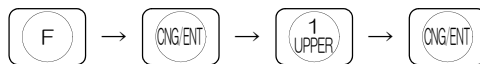

2) Input the Tare Weight. (9-Tare Weight)

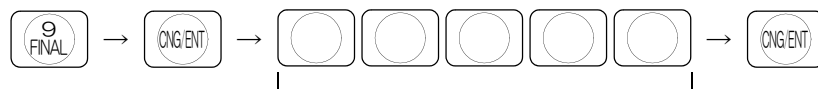

Tare Weight
(0 ~ 99999)





Tare subtraction and digital tare subtraction functions independently.

When  is pressed, tare subtraction will be executed at once then Net weight becomes 0 while digital tare subtraction is ON.

However, when tare subtraction is active in Restriction of the Tare Subtraction Function, ON/OFF in digital tare subtraction and Tare Weight maybe invalid.

5-14. Restriction of the Tare Subtraction Function

It can be restricted the function of digital tare subtraction or one touch tare subtraction.

- a) One-touch tare subtraction acceptance condition** (Select from Regularly / In stable mode)
It displays the timing of the Tare subtraction.
- b) Range of tare subtraction** (Whole range or from $0 < \text{Tare} \leq \text{Capacity}$)
- c) Tare Weight display with the  key** (Select from Valid / Invalid)
If it is set to be valid, the Tare Weight is displayed at the weight display section by pressing .
- d) Digital tare subtraction expansion** (Select from Valid / Invalid)
(Prohibition of Tare Weight and digital tare subtraction ON/OFF when one-touch tare subtraction is working.)
Select valid for inhibiting Tare Weight and digital tare subtraction ON/OFF when tare subtraction is in operation.

Operation

a), b), c), d)

1) Select setting mode 4.

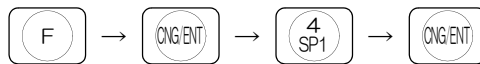

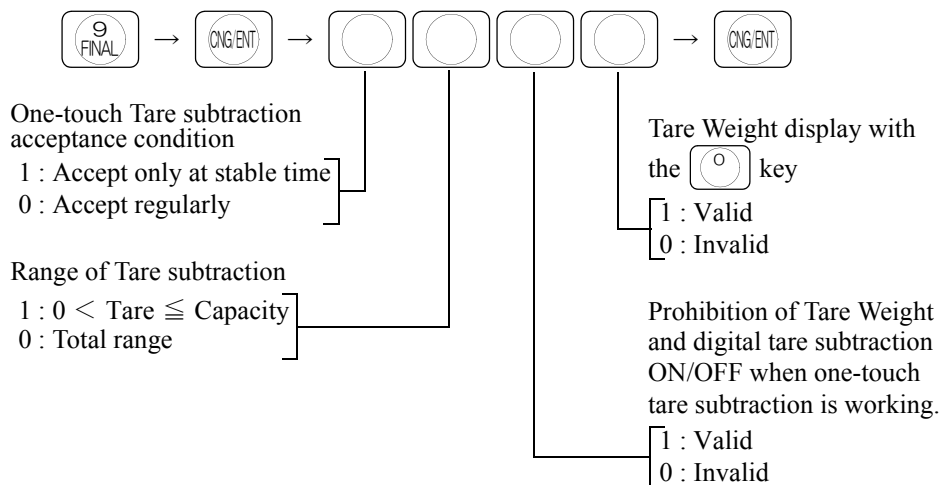

2) Put restrictions on the above four items.

(9-Restriction of the Tare Subtraction Function)



5-15. Switching Gross Weight/Net Weight Display

The switching Gross weight/Net weight is executed by pressing  on the main display. It can be switched over ON/OFF by using the signal from control connector to avoid false operation on the display.

- Internal key mode Switching with the  key on the normal screen.
Switching with the signal (edge input) from the control connector.
- External input mode..... Switching with the signal (revel input) from the control connector.

When external switch over is set,  on the main display becomes invalid.

Operation

1) Select setting mode 4.

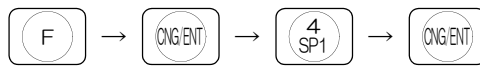

2) Select from Internal key mode/External input mode.

(7-External Function Selection)



Switching Gross weight/Net weight display

- 1 : External input mode
- 0 : Internal key mode

• Switching by external signal (A2pin)

- In internal key mode

Net weight display results on the ON edge (OFF → ON) of the external input.

Gross weight display results on the OFF edge (ON → OFF) of the external input.



- In external key mode

Net weight display results at ON, and Gross weight display results at OFF.

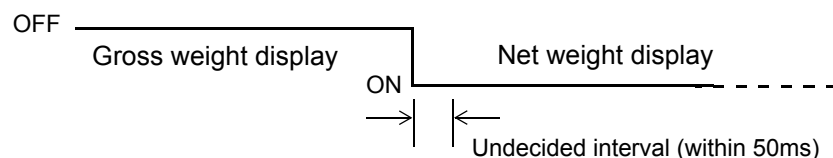

5-16. Reversing Symbol at Discharging Control

When discharging a fixed quantity material from material bin, Net weight becomes negative.

Discharging weight can be revised to positive by reversing the polarity of Net weight. Select from Net weight with - sign ON or Net weight with - sign OFF.

Operation

1) Select setting mode 4.

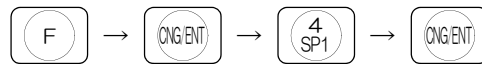

2) Select the sign. (7-External Function Selection)

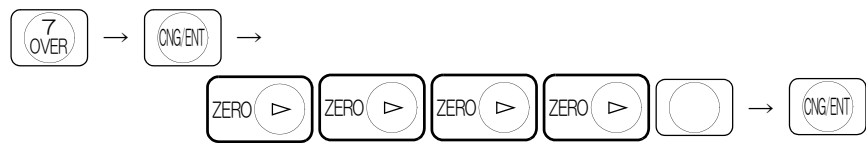





At discharging weighing time

1 : Net weight is displayed with the sign not reversed.
 0 : Net weight is displayed with the sign reversed.

5-17. Invalidation of Function Keys

Function keys on the front panel can be invalidated to prevent malfunctioning due to key operation.

- a) [TARE] key  (Select from Valid / Invalid)
- b) [TARE RESET] key  (Select from Valid / Invalid)
- c) [ZERO] key  (Select from Valid / Invalid)
- d) [GROSS/NET] key  (Select from Valid / Invalid)

Operation

a), b), c), d)

1) Select setting mode 2.

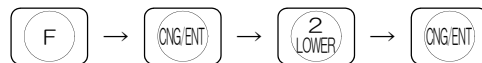

2) Select whether each key is Valid or Invalid. (5-Function Key Invalidation)

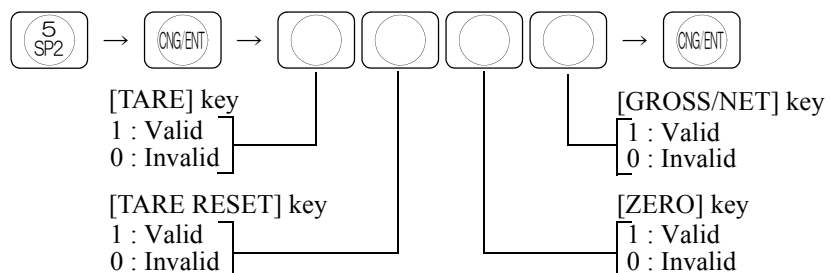

6. DISCHARGING CONTROL MODE

The discharging control means the control method for discharging raw material from the hopper or tank.

F701-C enables to discharge accurate quantity with the proper combination of setting the control of Final, Set Point 2, Set Point 1, Compensation and Judging Over, Under, Go and Timer for Comparison Inhibit, Judging.

According to the way of discharging, Feeding, Discharging or Simple comparison control or Sequence control is selectable.

6-1. Feeding Weighing and Discharging Weighing

6-1-1. Feeding Weighing

A method controlling a weight while feeding raw materials into a measuring tank (hopper).

Example of feeding weighing

In this example system, raw materials are to be fed from the material tank to the weighing tank. At first, the feeding valves are to be fully opened to feed, and closed in the order of Set Point 1 → Set Point 2, and Set Point 2 → Set Point 3 at the time of Final - Set Point 1, and Final - Set Point 2, respectively. The feeding valves are to be completely closed at the time of Final - Compensation. The weighed raw materials are to be discharged to a container by opening the discharge valves.

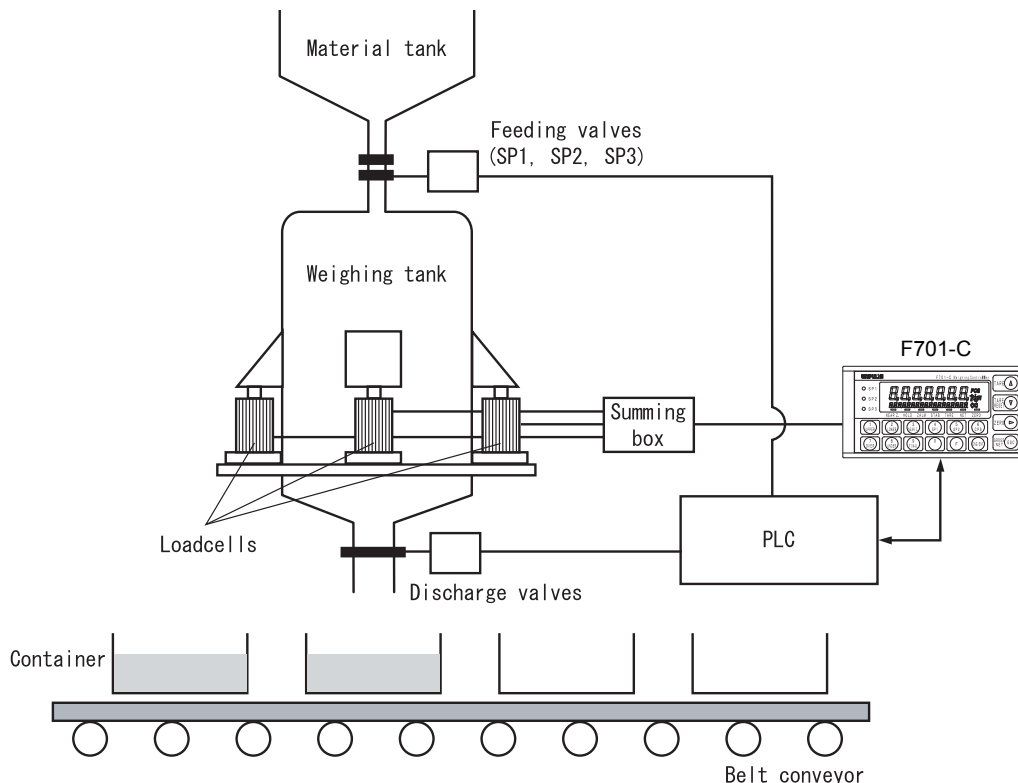

- (1) By setting external input Tare subtraction ON (or with the  key on the panel), Net weight is zeroed. (Tare subtraction)
- (2) The feeding valves are fully opened to start feeding. When the weighed value reaches (Final - Set Point 1), Set Point 1 output signal turns ON. (If the comparison inhibit timer is set, the timer starts.) Set Point 1 valve of the material tank is closed.
- (3) When the weighed value reaches (Final - Set Point 2), Set Point 2 output signal turns ON. (If the comparison inhibit timer is set, the timer starts.) Set Point 2 valve of the material tank is closed”.
- (4) When the weighed value reaches (Final - Compensation), Set Point 3 output signal turns ON, and if the judging timer is set, the timer starts. The feeding valves are completely closed.
- (5) After the judging timer expires, Over/Under judgment is made. If the weighed value exceeds the range of the Over/Under setting value, the over signal or under signal turns ON.
- (6) Raw materials are discharged from the weighing tank to a container. The valves of the weighing tank should be opened. Completion of discharge is confirmed with the Near Zero signal. In weighing from the second time onward, (1) ~ (5) are repeated.



The feeding valves and discharge valves should be opened and closed through the sequencer or relay sequence according to the control signals from the F701-C.

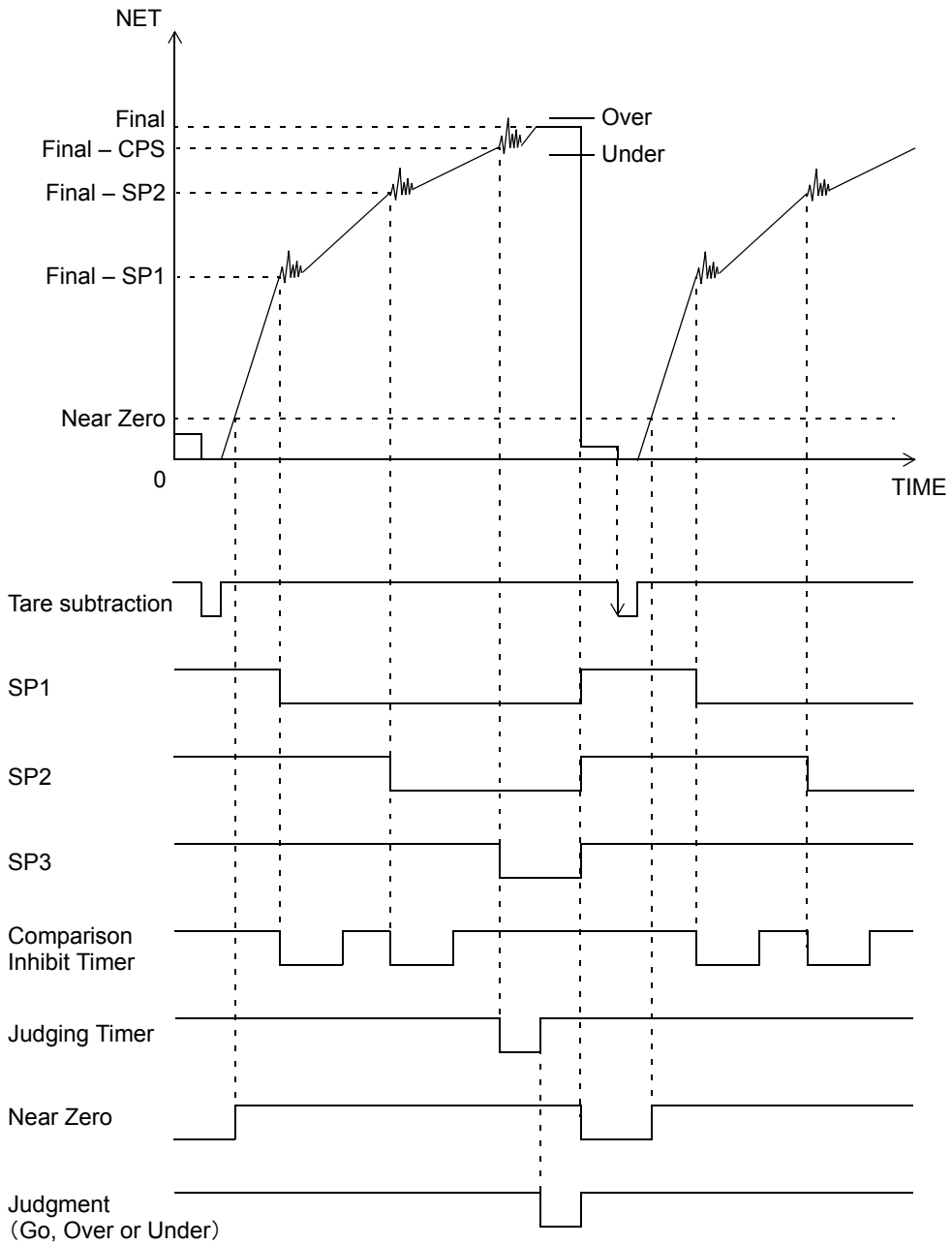



6-1-2. Discharging Weighing

First supply raw material into a metering tank (hopper), then controls a weight while discharging raw material from the metering tank.

Example of discharging weighing

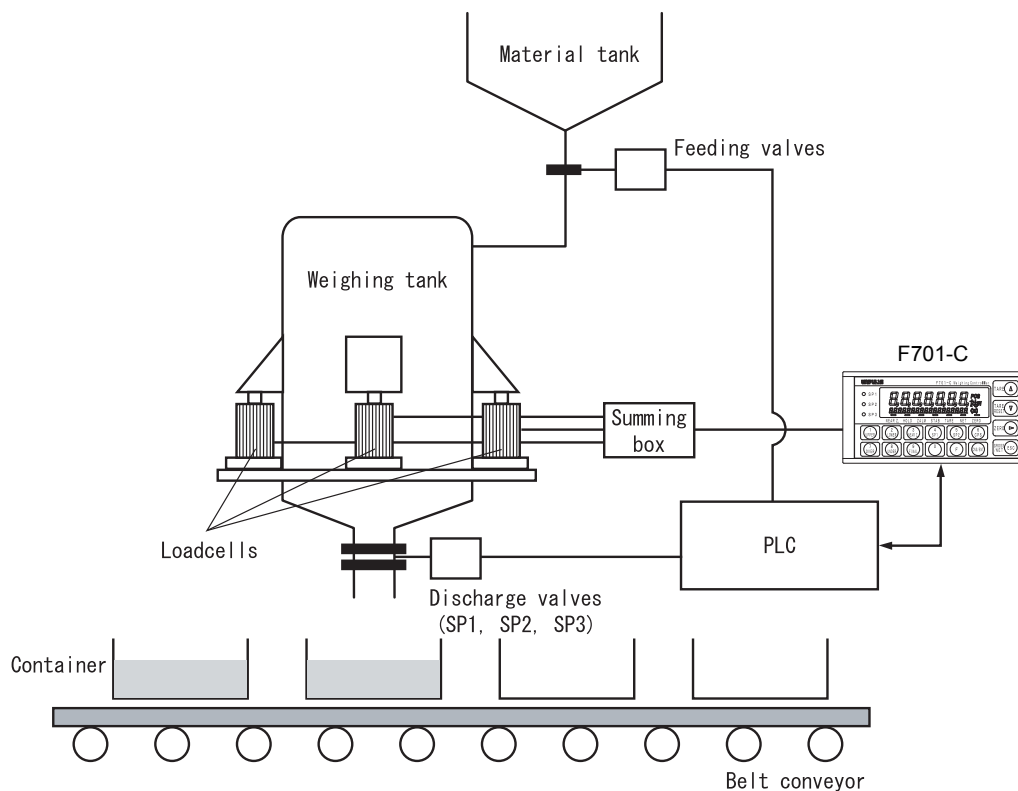
In discharging weighing, the amount of discharge can be weighed by adding negative weighed values. In this example system, raw materials are to be fed from the material tank to the weighing tank, and a fixed quantity of raw materials are to be discharged from the weighing tank to a container. At first, the discharge valves of the weighing tank are to be fully opened to discharge raw materials, and the discharge valves are to be closed in the order of Set Point 1 → Set Point 2, and Set Point 2 → Set Point 3 at the time of Final - Set Point 1, and Final - Set Point 2, respectively. The discharge valves are to be completely closed at the time of Final - Compensation, when one measurement is completed. When the weighing tank runs short, the feeding valves are to be opened to replenish the weighing tank with raw materials from the material tank to weigh.



- (1) The valves of the material tank are opened by the lower limit signal, and raw materials are fed into the weighing tank.
- (2) It is detected by the upper limit signal that the weighing tank is full, and the valves of the material tank are closed.
- (3) By setting external input Tare subtraction ON (or with the  key on the panel), Net weight is zeroed. (Tare subtraction)
- (4) The discharge valves are fully opened to start discharging. When the weighed value reaches (Final - Set Point 1), Set Point 1 output signal turns ON. (If the comparison inhibit timer is set, the timer starts.) The discharge valve (Set Point 1) is closed.
- (5) When the weighed value reaches (Final - Set Point 2), Set Point 2 output signal turns ON. (If the comparison inhibit timer is set, the timer starts.) The discharge valve (Set Point 2) is closed.
- (6) When the weighed value reaches (Final - Compensation), Set Point 3 output signal turns ON, and if the judging timer is set, the timer starts. The discharge valves are completely closed.
- (7) After the judging timer expires, Over/Under judgment is made. If the weighed value exceeds the range of the Over/Under setting value, the over signal or under signal is output. In weighing from the second time onward, (3) ~ (6) are repeated in a like manner.
- (8) When the weighing tank runs short of raw materials, the valves of the material tank are opened by the output of the lower limit signal to feed raw materials into the weighing tank.



The feeding valves and discharge valves should be opened and closed through the sequencer or relay sequence according to the control signals from the F701-C.

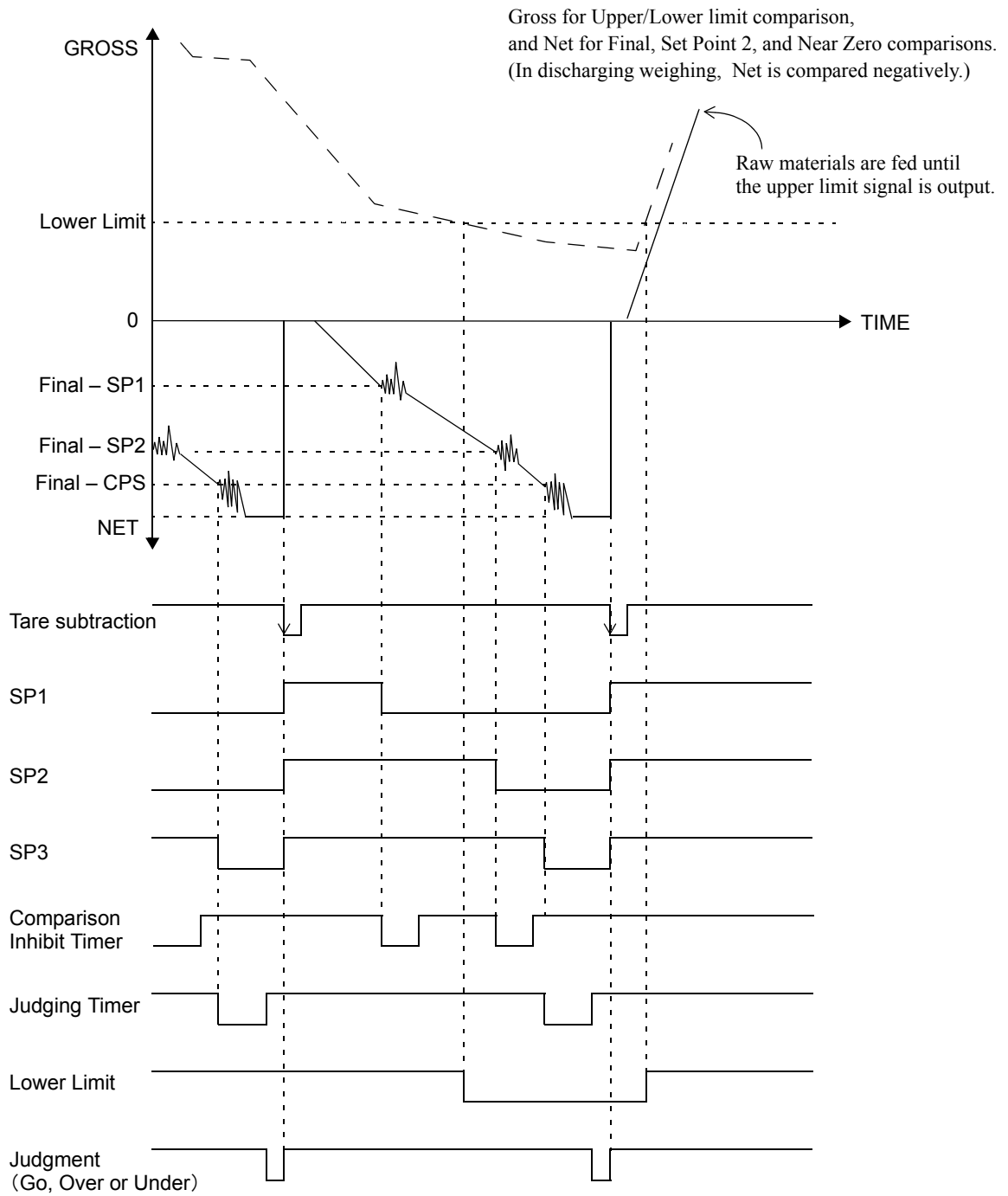

The Near Zero signal is used for discharge completion confirmation as in the case of feeding weighing.

6-1-3. Discharging Mode

Set the feeding or discharging. Selectable methods are feeding control, discharging control and external selection (Changing the feed/Discharge by the signal from control connector).

Operation

1) Select setting mode 2.

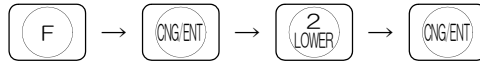

2) Select Discharging control mode. (1-Weighing Function 1)

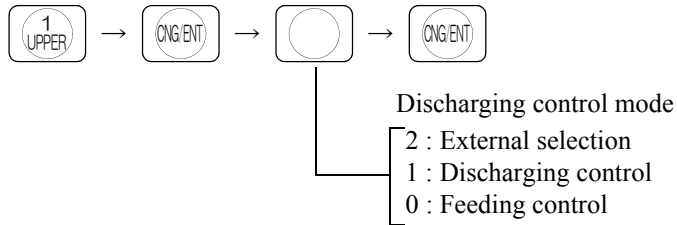

• Discharging control mode by external signal

Switch with the pin set at “Feed/Discharge” out of B2 to B5 pin on the control connector.
OFF → Feeding control, ON → Discharging control.

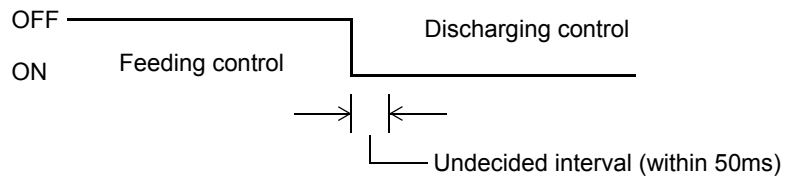

6-2. Simple Comparison Control and Sequence Control

6-2-1. Simple Comparison

Compares weight value with discharging value regularly.

Output is always ON when the weight value satisfies the conditions of final discharging setting items.

In simple comparison control, the next weighing is judged to be possible when the weight falls short of 25% of the Final after completion of the previous weighing.

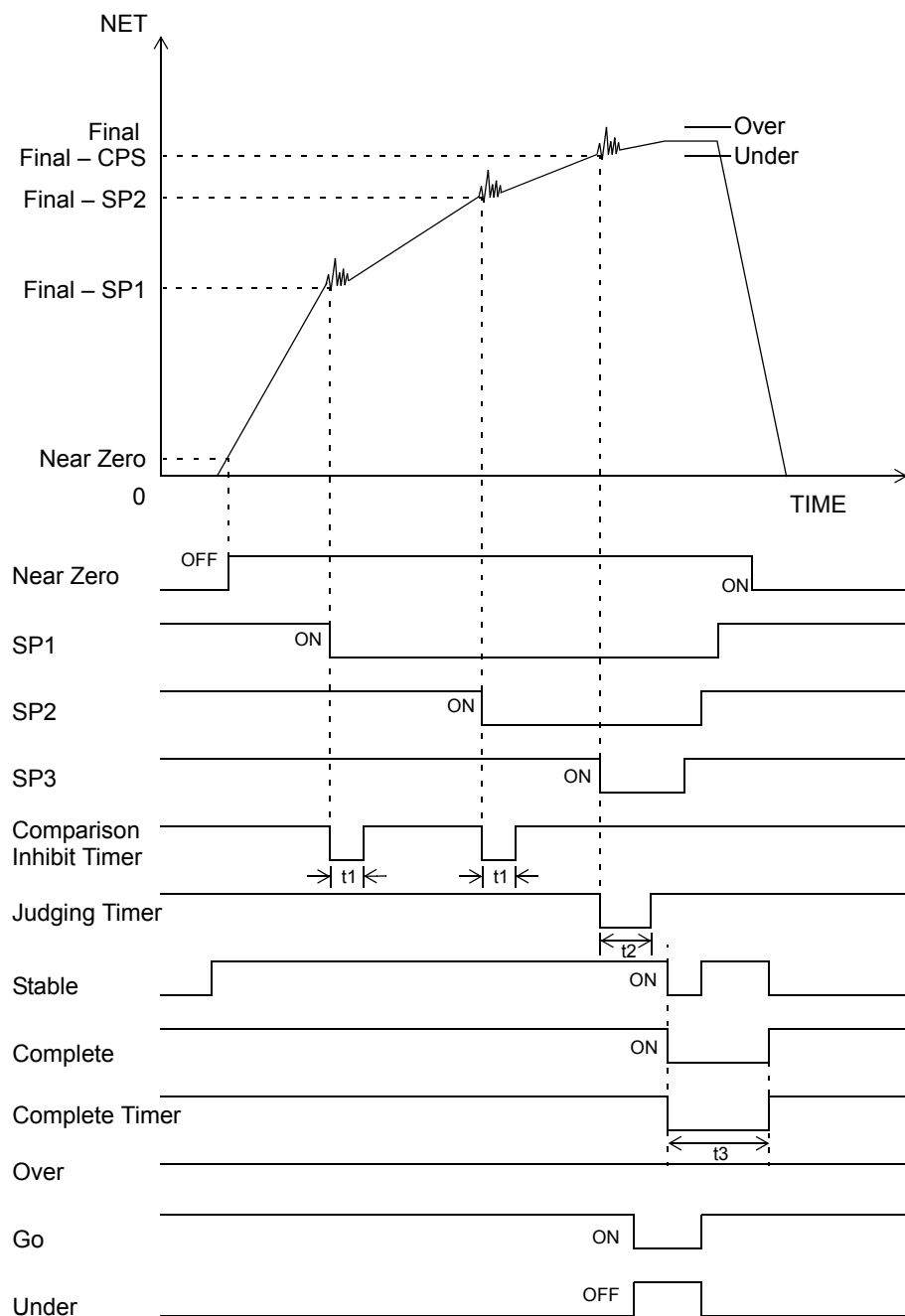

- The Over/Under comparison timing depends on the Over/Under comparison mode setting (Weighing Function 2 in setting mode 2).
(It is set at “Regularly” in the illustration.)
- The completion signal output timing depends on the complete signal output mode setting (Weighing Function 2 in setting mode 2).
- t1 : Comparison Inhibit Time Comparison Inhibit Time in setting mode 1
t2 : Judging Time Judging Time in setting mode 1
t3 : Complete Output Time Complete Output Time in setting mode 1
- Conditional expression
 - Near Zero turns ON when Weight value \leq Set value of Near Zero
 - SP1 output turns ON when Weight value \geq Final - SP1
 - SP2 output turns ON when Weight value \geq Final - SP2
 - SP3 output turns ON when Weight value \geq Final - CPS
 - Under turns ON when Weight value $<$ Final - Under
 - Over turns ON when Weight value $>$ Final + Over
 - Go turns ON when Final + Over \geq Weight value \geq Final - Under
- Select the weight value for Near Zero comparison from Gross weight/Net weight (Weighing Function 1 in setting mode 2).
- Select the comparison weight value for Set Point 1, Set Point 2 and Set Point 3 output signals, and Over, Go and Under judgment signals from Gross weight/Net weight (Weighing Function 1 in setting mode 2).

6-2-2. Sequential Control

This is a control method which compares the weight value with discharging value after starting signal of weighing ON.

When the starting signal ON, output of each signal of Set Point 1, Set Point 2, and Final turns ON then the signal turns OFF after weight value satisfied the each condition.

Sequential control can be conducted without connecting external sequencer in sequence control.

Sequence controls are classified into following categories.

- 1) Normal sequence control
Start weighing with start signal and finish the weighing by the output of complete signal.
- 2) Sequence control with adjust feeding
Adjust feeding is executed for the set period in adjusting time after completing the weighing.

① Normal sequence control (with Over/Under judgment)

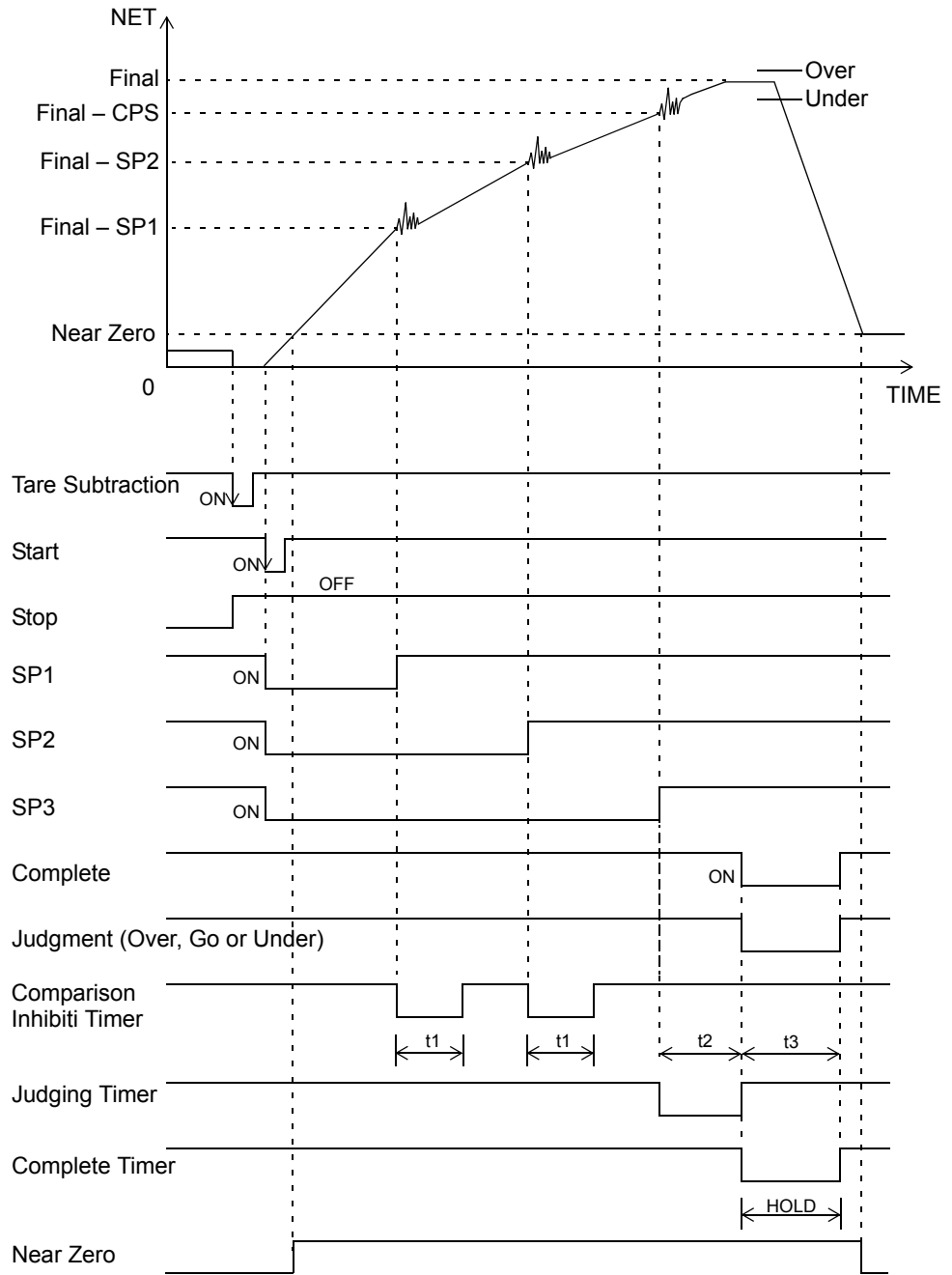

- The completion signal output timing depends on the complete signal output mode setting (Weighing Function 2 in setting mode 2).
- The Over/Under comparison timing is such that the Over/Under comparison mode setting (Weighing Function 2 in setting mode 2) is ignored, but comparisons are made when the completion output is ON, and the weight value is held.
- Upper/Lower limit comparison is always made in defiance of the setting of Upper/Lower limit comparison mode (Weighing Function 2 in setting mode 2).
- t1 : Comparison Inhibit Time Comparison Inhibit Time in setting mode 1
t2 : Judging Time Judging Time in setting mode 1
t3 : Complete Output Time Complete Output Time in setting mode 1
- Conditional expression
 - Near Zero turns ON when Weight value \leq Set value of Near Zero
 - ※ Set Point 1 / Set Point 2 / Set Point 3 feeding gate signal is turned ON at the ON edge (OFF \rightarrow ON) of the start signal.
 - SP1 turns OFF when Weight value \geq Final - SP1
 - SP2 turns OFF when Weight value \geq Final - SP2
 - SP3 turns OFF when Weight value \geq Final - CPS
 - Under turns ON when Weight value $<$ Final - Under
 - Over turns ON when Weight value $>$ Final + Over
 - Go turns ON when Final + Over \geq Weight value \geq Final - Under
- Select the weight value for Near Zero comparison from Gross weight/Net weight (Weighing Function 1 in setting mode 2).
- Select the comparison weight value for Set Point 1, Set Point 2 and Set Point 3 output signals, and Over, Go and Under judgment signals from Gross weight/Net weight (Weighing Function 1 in setting mode 2).

② Normal sequence control (without Over/Under judgment)

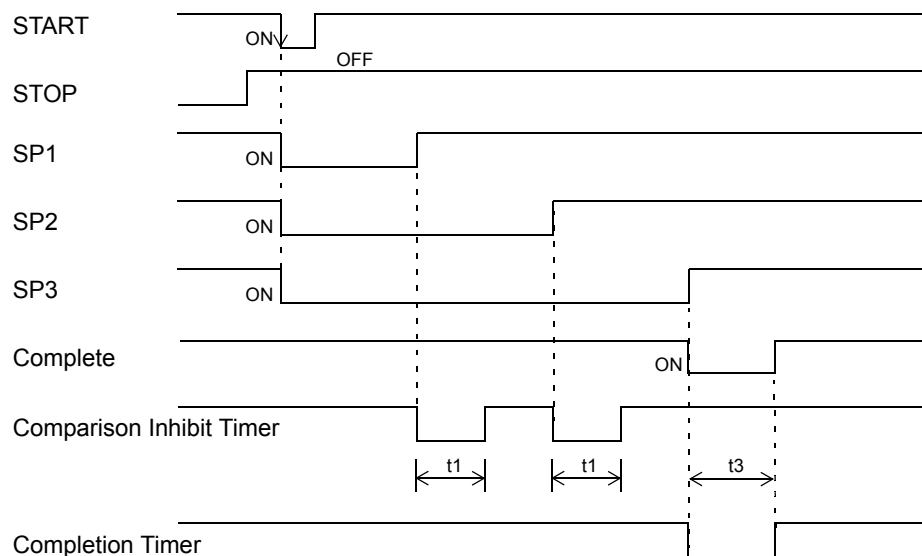

- When the setting of Judging Times in setting mode 1 is 00, Over/Under judgment is not made.
- The completion signal output timing is such that the complete signal output mode setting (Weighing Function 2 in setting mode 2) is ignored, but it is output at the OFF edge (ON → OFF) of the final signal (Set Point 3 signal).
- t_1 : Comparison Inhibit Time Comparison Inhibit Time in setting mode 1
- t_3 : Complete Output Time Complete Output Time in setting mode 1

③ Sequence with adjust feeding

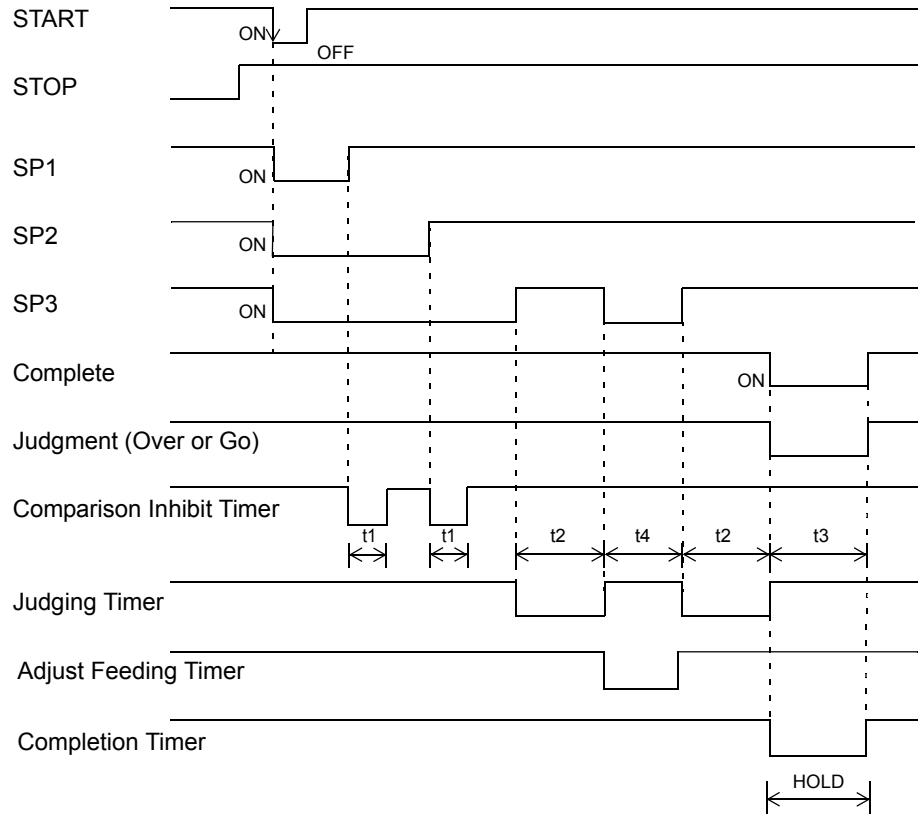

- Set adjust feeding (ON/OFF) (Sequence Mode in setting mode 2) to ON.
 - The completion signal output timing depends on the complete signal output mode setting (Weighing Function 2 in setting mode 2).
 - The Over/Under comparison timing is such that the Over/Under comparison mode setting (Weighing Function 2 in setting mode 2) is ignored, but comparisons are made when the completion output is ON, and the weight value is held.
 - Upper/Lower limit comparison is always made in defiance of the setting of Upper/Lower limit comparison mode (Weighing Function 2 in setting mode 2).
- | | | |
|--------|-------------------------|---|
| ● t1 : | Comparison Inhibit Time | Comparison Inhibit Time in setting mode 1 |
| t2 : | Judging Time | Judging Time in setting mode 1 |
| t3 : | Completion output time | Completion Output Time in setting mode 1 |
| t4 : | Adjust Feeding Time | Adjust Feeding Time in setting mode 1 |

About the stop signal

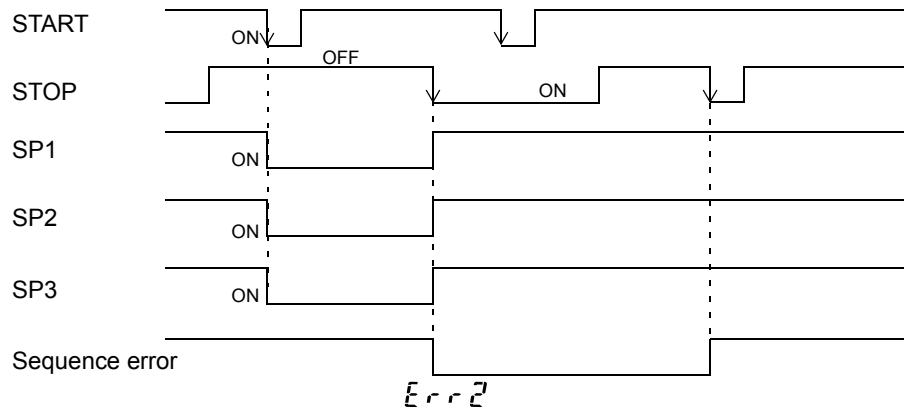

- When the stop signal is turned ON, all the signals of Set Point 1 output, Set Point 2 output and Set Point 3 output are turned OFF.
- If the start signal is turned ON when the stop signal is ON, a sequence error will result.
- For resetting the sequence error, input the stop signal again.

6-2-3. Sequence Mode

Setting Simple comparison/Sequence control.

Operation

1) Select setting mode 2.

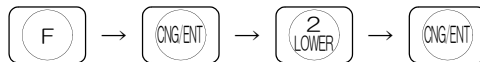

2) Select from Simple comparison mode/Sequence mode. (4-Sequence Mode)

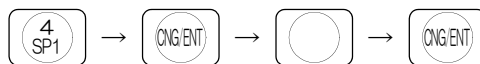

- 1 : Sequence mode
- 0 : Simple comparison mode

6-3. Auto Free Fall Compensation Regulation / Auto Free Fall Compensation ON/OFF / Average Count of Auto Free Fall Compensation / Auto Free Fall Compensation Coefficient

Auto free fall compensation adjusts the amount of suspended ingredient automatically to reduce weight error. Register auto free fall compensation parameter.

Principle of auto free fall compensation

Sampling the weight value when the complete signal turns ON after Set Point 3 finished. Record "n" times(A) the difference(D) between set Final value and actual weight value, average the difference and multiplied by compensation coefficient, then add the result of Compensation value.

$$\text{Value added to Compensation value} = \frac{(D_1 + D_2 + D_3 \cdots D_A)}{A} \times C$$

F701-C can regulate the value of D for minimizing the errors.

When D is within the range of $(\text{Final} + \text{AFFC.}) \geq \text{Actual weight} \geq (\text{Final} - \text{AFFC.})$, F701-C processes auto free fall compensation.

And when compensation feeding is ON in Sequence Mode, F701-C samples the weight value before compensation feeding.

Request

The auto free fall compensation function stores compensation samples by using the Over/Under judgment signals.

If the number of Judging Times is set to 00 (no judgment), the F701-C cannot store such samples for auto free fall compensation, so that the compensation function does not work.

For using the auto free fall compensation function, set the number of Judging Times to 01 or more.

For details, please refer to "a) Judging Times" on P.94.

Example)	Final	20.000
	AFFC.	0.100
	Average count of AFFC.	4
	AFFC. coefficient	2/4

Times	Actual Weighing	Error	Average count of AFFC.	CPS
0			0	← Power ON
1	20.050	+0.050	1	0.500
2	20.040	+0.040	2	0.500
3	20.070	+0.070	3	0.500
4	20.080	+0.080	4 → 0	0.500
		$+0.240/4 = 0.060$		
			$0.060 \times 2/4 = 0.030$	→ CPS Value
5	20.020	+0.020	1	0.530
6	20.000	0.000	2	0.530
7	20.010	+0.010	3	0.530
8	20.110	(+0.110)	← × 3	0.530
9	20.010	+0.010	4 → 0	0.530
		$+0.040/4 = 0.010$		
			$0.010 \times 2/4 = 0.005$	→ CPS Value
10	19.880	(-0.120)	← × 1	0.535
11	19.990	-0.010	1	0.535
12	20.010	+0.010	2	0.535
13	20.000	0.000	3	0.535
14	19.980	-0.020	4 → 0	0.535
		$-0.020/4 = -0.005$		
			$-0.005 \times 2/4 = -0.003$	→ CPS Value
				0.532

※ When Compensation value is changed, average count of AFFC. becomes 0.



Setting compensation coefficient

Compensation coefficient can be selected from 1/4, 2/4, 3/4, or 1.

You can get more accurate compensation value by selecting 1 when each weight value is approximate same in each measuring or by selecting 1/4 ~ 2/4 when each weight value fluctuates in each measuring.

Setting compensation parameter

- a) AFFC.** Set the regulated value to avoid the compensation value becomes extremely large (or small).
(Input range / 0 ~ 99999)
- b) AFFC. ON/OFF** Selection of AFFC.
When CC-Link is installed, writing of free fall compensation data can be prohibited, at the time of writing in the exclusive data area.
(Select from OFF, ON, ON (Communication OP invalid))
- c) Average count of AFFC.** Number of weighing value for calculating the average of compensation.
(Input range / 1 ~ 9)
- d) AFFC. coefficient** Setting for avoiding fluctuations of the compensation value be computed by multiplying the compensation and the coefficient of not more than 1.
(Select from 1, 3/4, 2/4 or 1/4)

Operation

a)

1) Select setting mode 1.

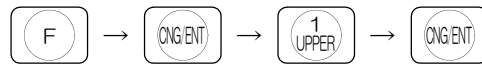

2) Input the AFFC.. (7-Auto Free Fall Compensation Regulation)

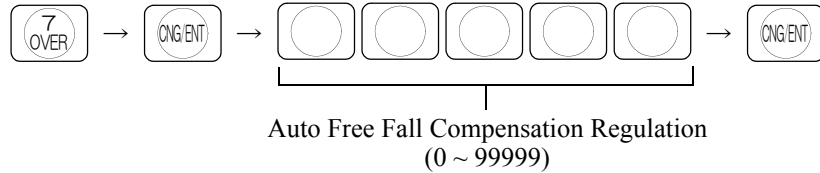

b), c), d)

1) Select setting mode 2.

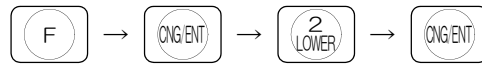

2) Set AFFC. ON/OFF, average count of AFFC. and AFFC. coefficient.

(3-Weighing Function 3)

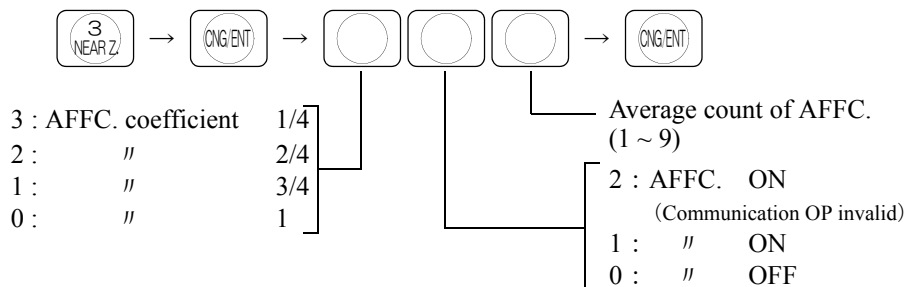

6-4. Final / Set Point 2 / Set Point 1 / Compensation / Over / Under

Setting for controlling and judging the discharge.

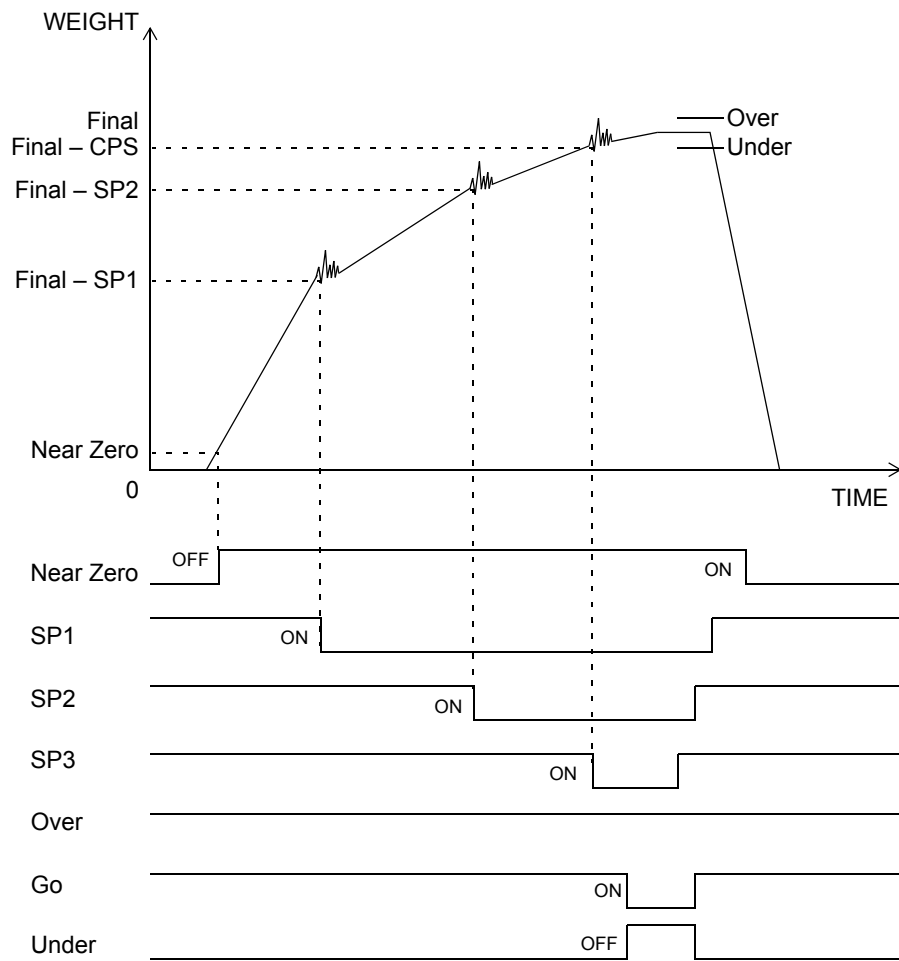

Outputting the control signal to external part from the control connector by the value set here.

Setting Discharging Fixed Value

Setting	Display	Judging Formula
Near Zero	NZ	Weight value \leq Set value of Near Zero
Set Point 1	SP1	Weight value \geq Final - SP1
Set Point 2	SP2	Weight value \geq Final - SP2
Set Point 3	SP3	Weight value \geq Final - CPS
Under		Weight value $<$ Final - Under
Over		Weight value $>$ Final + Over
Go		Final + Over \geq Weight value \geq Final - Under

- a) **Final** (Input range / 0 ~ 99999)
- b) **Set Point 2** (Input range / 0 ~ 99999)
- c) **Set Point 1** (Input range / 0 ~ 99999)
- d) **Compensation** (Input range / 0 ~ 9999)
- e) **Over** (Input range / 0 ~ 999)
- f) **Under** (Input range / 0 ~ 999)

※ Not for using Set Point 1 and Set Point 2, make the settings of Set Point 1 and Set Point 2 equal to the Final.

Operation

a)

1) Select setting mode 0.

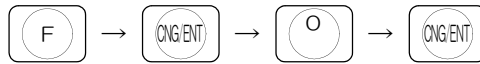

2) Input the Final. (9-Final)

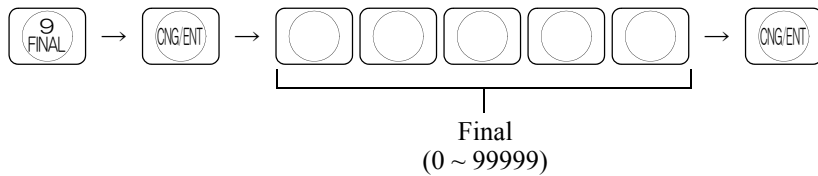

b)

1) Select setting mode 0.

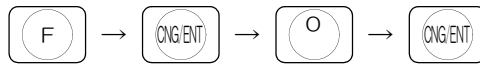

2) Input the Set Point 2. (5-Set Point 2)

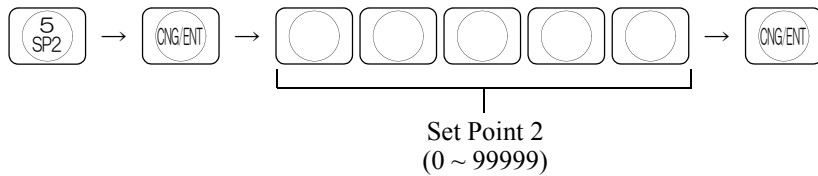

c)

1) Select setting mode 0.

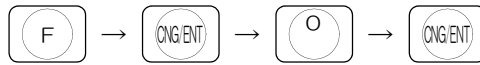

2) Input the Set Point 1. (4-Set Point 1)

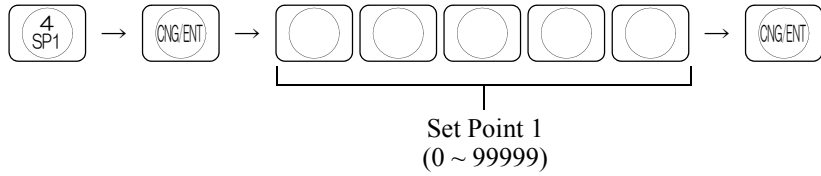

d)

1) Select setting mode 0.

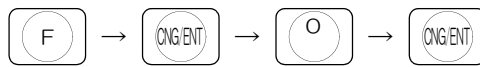

2) Input the Compensation. (6-Compensation)

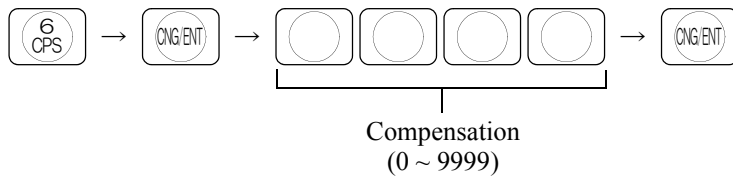

e)

1) Select setting mode 0.

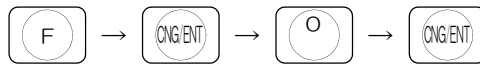

2) Input the Over. (7-Over)

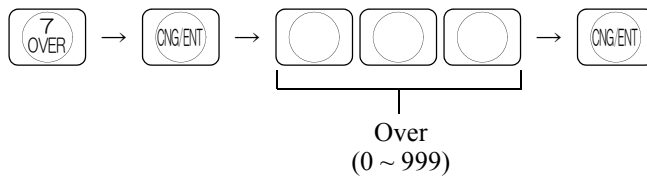

f)

1) Select setting mode 0.

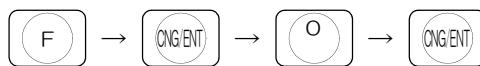

2) Input the Under. (8-Under)

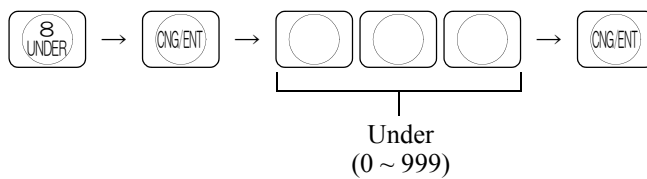

6-5. Near Zero / Upper Limit / Lower Limit

Setting for judging the final discharging function.

〈 Conditional formula 〉

a) Near Zero	Weight value \leq Near Zero	ON	(Input range / 0 ~ 99999)
b) Upper Limit	Weight value $>$ Upper Limit	ON	(Input range / 0 ~ 99999)
c) Lower Limit	Weight value $<$ Lower Limit	ON	(Input range / 0 ~ 99999)

Operation

a)

1) Select setting mode 0.

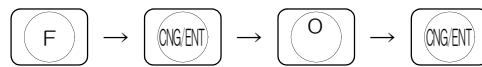

2) Input the Near Zero. (3-Near Zero)

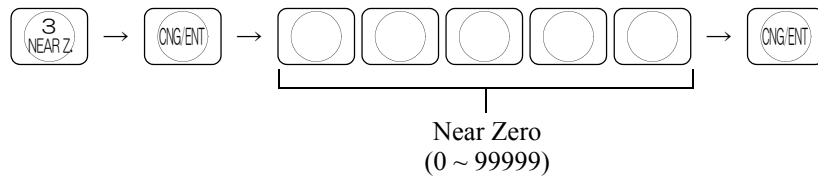

b)

1) Select setting mode 0.

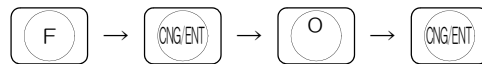

2) Input the Upper Limit. (1-Upper Limit)

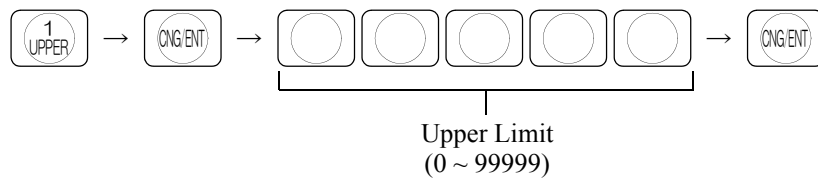

c)

1) Select setting mode 0.

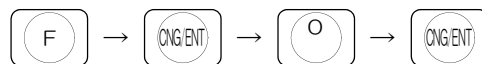

2) Input the Lower Limit. (2-Lower Limit)

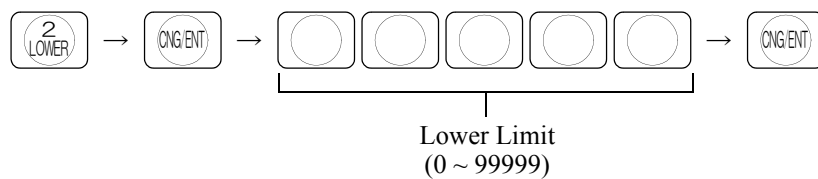

6-6. Upper/Lower Limit Comparison / Upper/Lower Limit Comparison Mode / Near Zero Comparison / Final and Comparison / Over/Under Comparison Mode

It enables to select the weight (Gross/Net) to be compared and the timing of comparison at the each comparison point of Upper/Lower limit, Near Zero or Over/Under.

- a) **Upper/Lower limit comparison** (Select from Gross weight / Net weight / Comparison OFF)
- b) **Upper/Lower limit comparison mode** (Select from Comparison Regularly / External Judging ON)
- c) **Near Zero comparison** (Select from Gross weight / Net weight / Comparison OFF / | Gross weight | / | Net weight |)
- d) **Over/Under comparison** (Select from Gross weight / Net weight / Comparison OFF)
- e) **Over/Under comparison mode** (Select from Comparison Regularly / External Judging ON / Complete Signal ON / Complete ON Hold)

Operation

a), c), d)

1) Select setting mode 2.

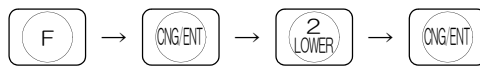

2) Set Upper/Lower limit comparison, Near Zero comparison and Final and Over/Under comparison. (1-Weighing Function 1)

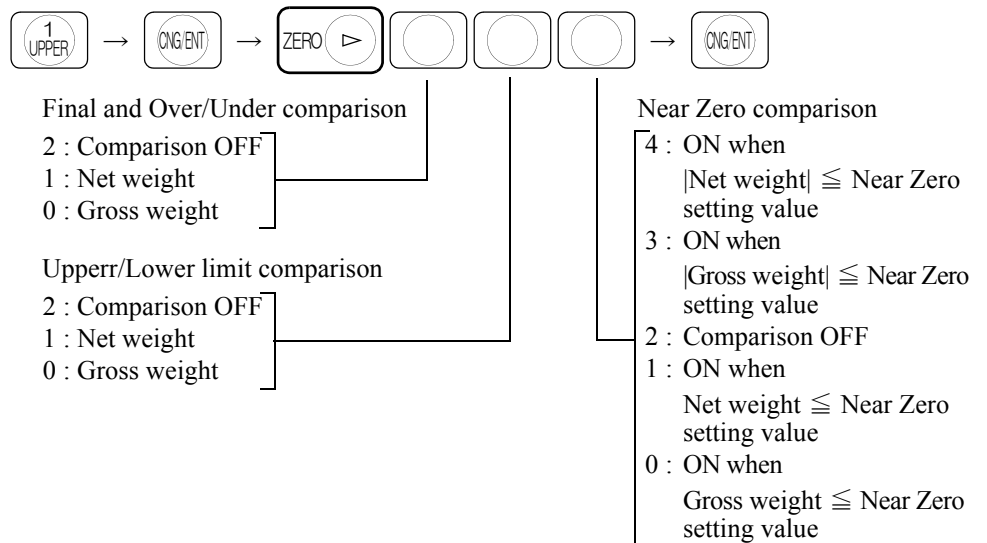

b), e)

1) Select setting mode 2.

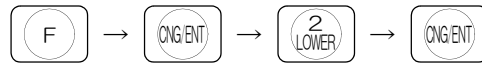

2) Set Upper/Lower limit comparison mode and Over/Under comparison mode.

(2-Weighing Function 2)



Over/Under comparison mode
 3 : Comparison is made, and the weight value is held when the complete output is ON.
 2 : Comparison is made when the complete output is ON.
 1 : Comparison is made when the external judgment input is ON.
 0 : Comparison regularly

Upper/Lower limit comparison mode
 1 : Comparison is made when the external judgment input is ON.
 0 : Comparison regularly

B2 to B5 pin on the control connector can be used as judgment signals by setting.

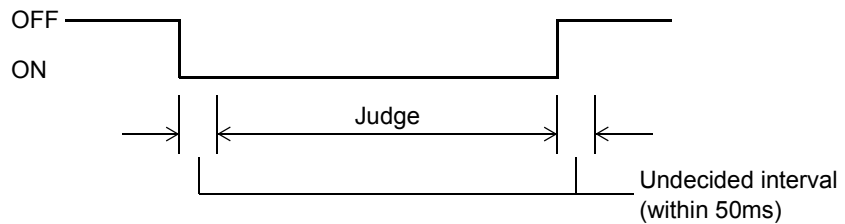

Be aware that no judgment is made if there is no judgment input set by the input selection when the over/under comparison mode or the upper/lower limit comparison mode is set at "Comparison is made when the external judgment input is ON." However, the external judgment input cannot be used in the sequence mode.

6-7. Complete Signal Output Mode / Complete Output Time / Judging Time / Comparison Inhibit Time / Output Selection 2

• Comparison Inhibit Time/Judging Time

The function which inhibits the comparison for certain period of time to eliminate false control or judgement with the vibration caused by opening or closing of valve.

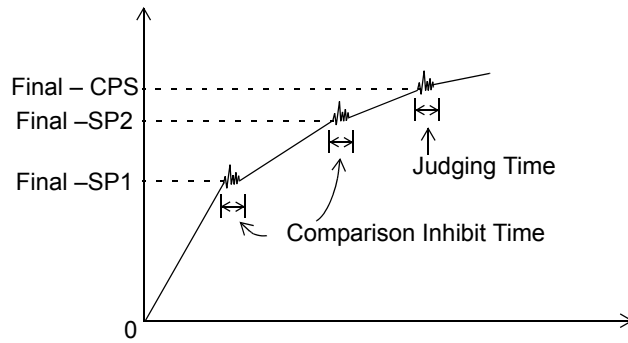

• Complete Output Time

Setting the period of complete signal (Control connector B10pin) output when the weighing is completed.

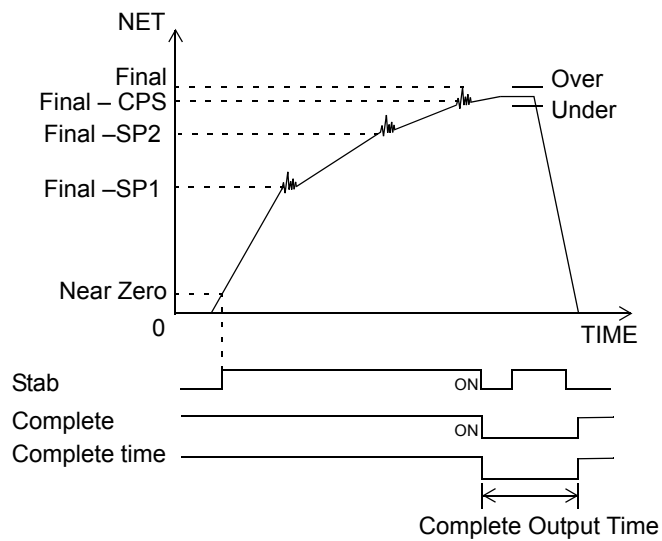

- a) **Complete signal output mode** (Select from Judging Time / Judge & Stable / Judging / Stable)
- b) **Complete Output Time** (Input range / 0.00 ~ 9.99)
- c) **Judging Time** (Input range / 0.00 ~ 9.99)
- d) **Comparison Inhibit Time** (Input range / 0.00 ~ 9.99)
- e) **Output Selection 2** (Select from Go output / Complete output)

Operation

a)

1) Select setting mode 2.

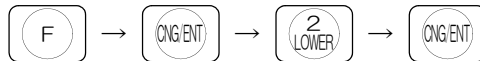

2) Select Complete signal output mode. (2-Weighing Function 2)



Complete signal output mode

- 2 : ON for the Complete Output Time from when the judging timer has expired or from when the weight value becomes stable after the SP3 signal turns ON.
- 1 : ON for the Complete Output Time from when the weight value becomes stable after the judging timer has expired.
- 0 : ON for the Complete Output Time from when the judging timer has expired.

b)

1) Select setting mode 1.

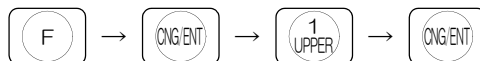

2) Input the Complete Output Time. (3-Complete Output Time)

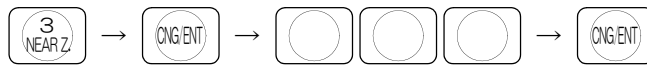

Complete Output Time (sec.)
(0.00 ~ 9.99)

c)

1) Select setting mode 1.

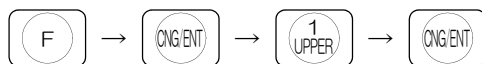

2) Input the Judging Time. (2-Judging Time)

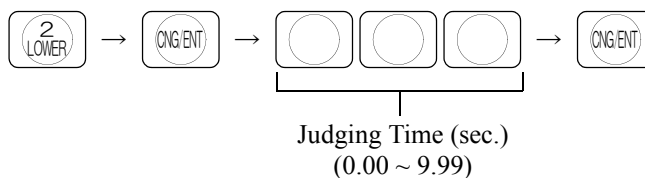

d)

1) Select setting mode 1.

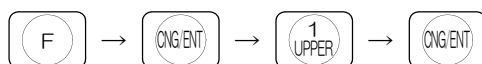

2) Input the Comparison Inhibit Time. (1-Comparison Inhibit Time)

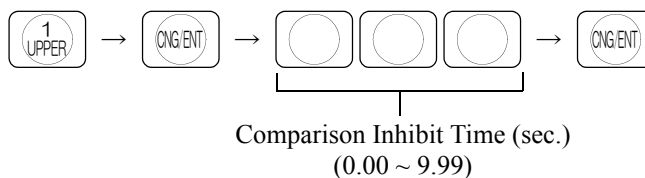

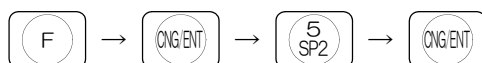

e)

1) Select setting mode 5.

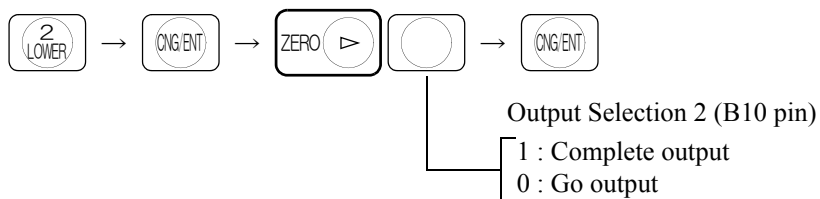

2) Set Output selection 2. (2-Output Selection)



 • Unless the weight value once drops down to 25% or less of the Final after the complete output, the complete output will not turn on after the next weighing.

• If the Final is set at 0, the complete output may turn on at power-on.

6-8. Judging Times / AZ Times / At Start Near Zero Confirmation / At Start Weight Value Confirmation / Adjust Feeding / Adjust Feeding Time

a) Judging Times

The Selection whether conduct the judgment on Over, Under or Go when complete signal is displayed after completing the weighing.

Set the number from 00 to 99.

00 : Without judging

01 : Conducting judging every time

02 : Conducting an judging for every twice

03 : Conducting an judging for every three times

⋮

99 : Conducting an one judging in 99 times

< Example > When the number of Judging Times is set to 2.

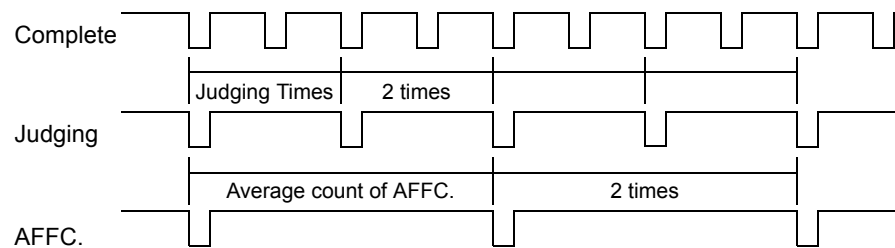

Request

The auto free fall compensation function stores compensation samples by using the Over/Under judgment signals.

If the number of Judging Times is set to 00 (no judgment), the F701-C cannot store such samples for auto free fall compensation, so that the compensation function does not work.

For using the auto free fall compensation function, set the number of Judging Times to 01 or more.

b) AZ times

The selection whether the weight value is set 0 or not at start.

When weight value = Gross weight, conduct digital zero or when weight value = Net weight, subtract the Tare to set weight value for 0.

Set the number from 00 to 99.

00 : Without auto 0

01 : Conduct an auto zero every time.

02 : Conduct an auto zero for every twice.

03 : Conduct an auto zero for every three times.



99 : Conducting one auto zero in 99 times

< Example > When the number of AZ Times is set to 3.

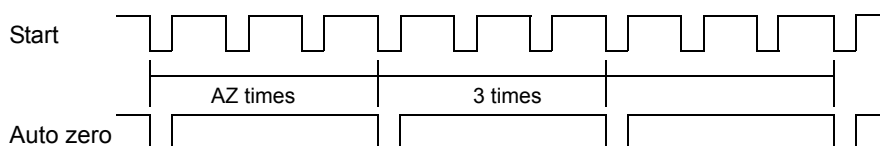

- Auto zero is operated at the same time as start signal is outputted.
- “Err 3” will be displayed if zero alarm is caused by auto zero.
- Tare subtraction and digital zero can be operated via the front keys or the control connector even if you set the auto zero to (00) without auto zero.

c) Near Zero confirmation at the start of weighing

Setting for confirming whether Near Zero signal ON at the start of weighing.

(Select from ON or OFF).

Weighing will normally start if the Near Zero is ON. “Err 4” is displayed if the Near Zero is OFF.

Refer to "6-5.Near Zero / Upper Limit / Lower Limit" on P.88 concerning Near Zero setting.

d) Weight value confirmation at the start of weighing

Confirm whether the weighing value has reached SP1 at the start of weighing.

(select from ON or OFF) If it has, “ $\bar{E} \cdot \cdot \bar{5}$ ” will be displayed.

Refer to "6-4.Final / Set Point 2 / Set Point 1 / Compensation / Over / Under" on P.85 concerning Set Point 1 setting.

e) Adjust feeding (Select from ON/OFF)

f) Adjust feeding time (Input range / 0.00 ~ 9.99)

Operation

a)

1) Select setting mode 1.

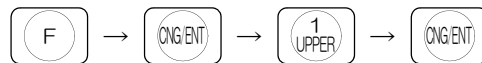

2) Input the Judging Times. (6-Judging Times)

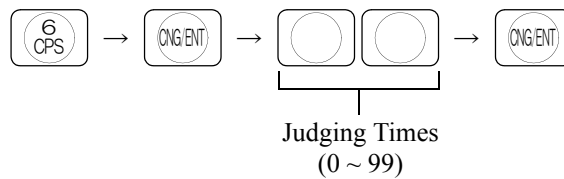
**b)**

1) Select setting mode 1.

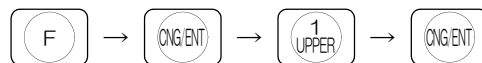

2) Input the Auto Zero Times. (5-Auto Zero Times)

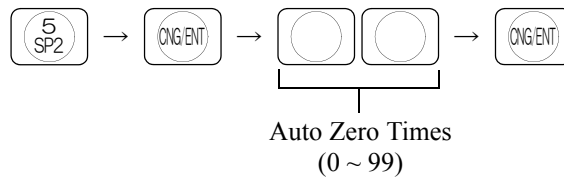

c), d), e)

1) Select setting mode 2.

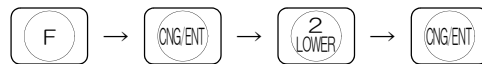

2) Set Near Zero check at start-time, weight value check at start-time and adjust feeding.

(4-Sequence Mode)

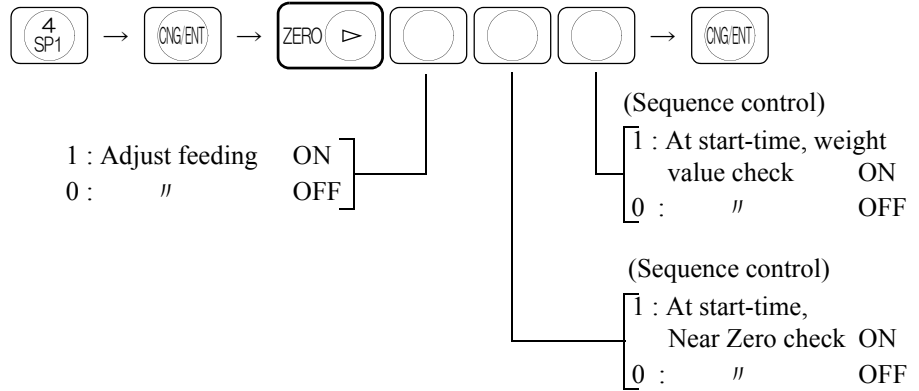

f)

1) Select setting mode 1.

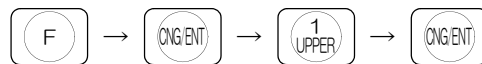

2) Input the Adjust Feeding Time. (4-Adjust Feeding Time)

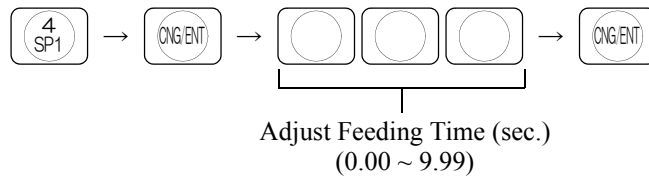

6-9. Net Over / Gross Over

This function warns you that the Net or Gross weight exceeds the entered control value.

a) Net Over (Input range / 0 ~ 99999)

b) Gross Over (Input range / 0 ~ 99999)

	Conditional formula	Display
Net Over	Net weight > Net Over set value	oFL1
Gross Over	Gross weight > Gross Over set value	oFL3

Operation

a)

1) Select setting mode 3.

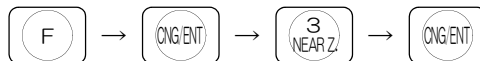

2) Input the Net Over. (4-Net Over)

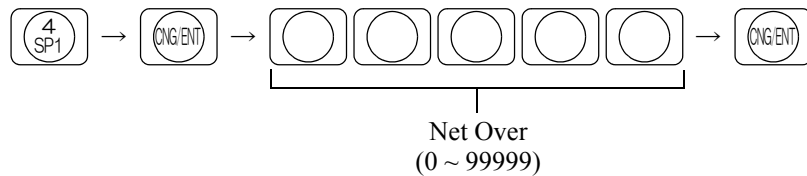

b)

1) Select setting mode 3.

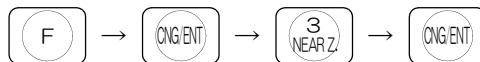

2) Input the Gross Over. (5-Gross Over)

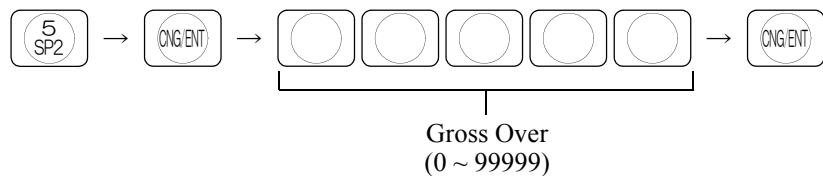

6-10. Weight Error / Sequence Error

Weight error

When the display is LOAD, OFL or ZALM, the output turns ON.

Sequence error

When the display is Err, the output turns ON.

Weight error and sequence error output signals are selectable by setting.

Operation

1) Select setting mode 5.

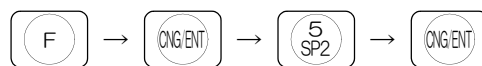

2) Set Output selection 1. (2-Output Selection)



Output Selection 1 (B9 pin)

- 2 : Weight error or sequence error
- 1 : Sequence error
- 0 : Weight error

7. STATISTICAL AND ACCUMULATION FUNCTION SETTING AND OPERATION

Weight values are accumulated by this function. Based on the accumulated weight data, statistical data, such as the maximum, minimum, and average, are calculated.

Weight values can be accumulated by the auto accumulation command or external input/output signal, through RS-232C communication, RS-485 communication (option), CC-Link (option).

Up to 10000 accumulations can be made. For 10001 or more accumulations, the operation "Accumulation clear" must be performed to clear the accumulated and statistical data.

While the number of accumulations is 10000, an accumulation error results. The accumulation error can be outputted from B11 pin out of the external input/output signals (by setting).

Even while the accumulation error is given, other weighing operations and the print command (SI/F), etc., are not affected.

Operations other than those relating to statistics and accumulations are performed normally.

The accumulation value and statistical data can be referred to in the subdisplay area or in the setting mode 8.

(For details, please refer to "1-1.Front Panel" ② Subdisplay on P.1, "3-2-7.Setting Mode 8" on P.37.)



The accumulated weight could be Gross or Net weight, which is selected in Over / Under Comparison of the Comparison Mode.

7-1. Data Display

The statistics data accumulated in F701-C are displayed.

Weight values can be accumulated by weighing with the auto accumulation command ON or by turning ON the external signal input “Accumulation command”.

What is displayed is average weight, max. value, min. value, general standard deviation, sample standard deviation, accumulation count, latest accumulation data, or max. - min.

Operation

1) Select setting mode 8.

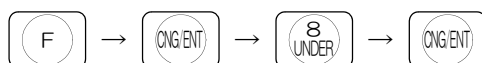

2) Set the data to be displayed.

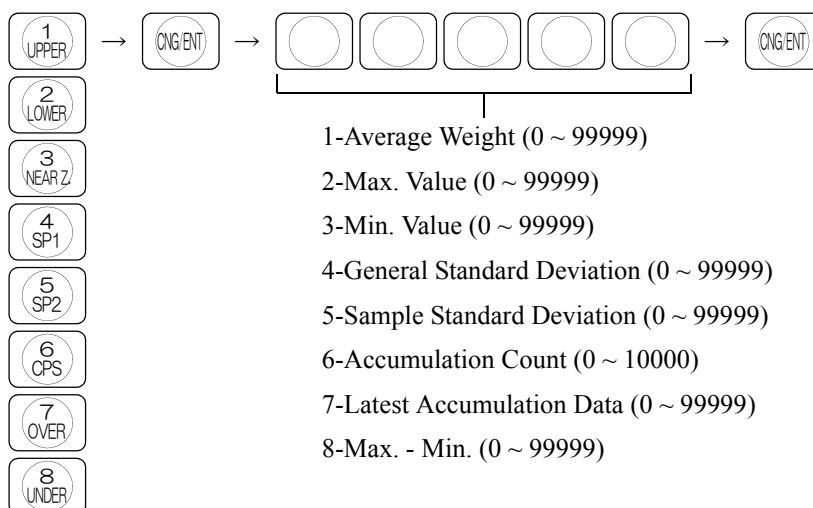

7-2. Accumulation Command

Weight values can be accumulated by the external input/output signal or through the RS-232C, RS-485 (option), CC-Link (option) when desired.

Accumulation command by the external input/output

Set one of the B2 to 5 pins out of the external input/output signals to “accumulation command”.

An immediate accumulation is executed at the ON edge of an input to the set pin.

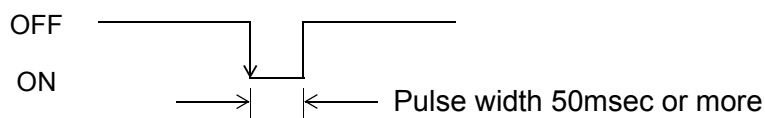

Operation

1) Select setting mode 5.

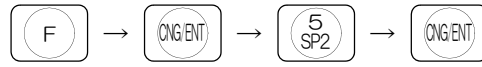

2) One of input selections 1~4 is set to the Accumulation Command. (1-Input Selection)

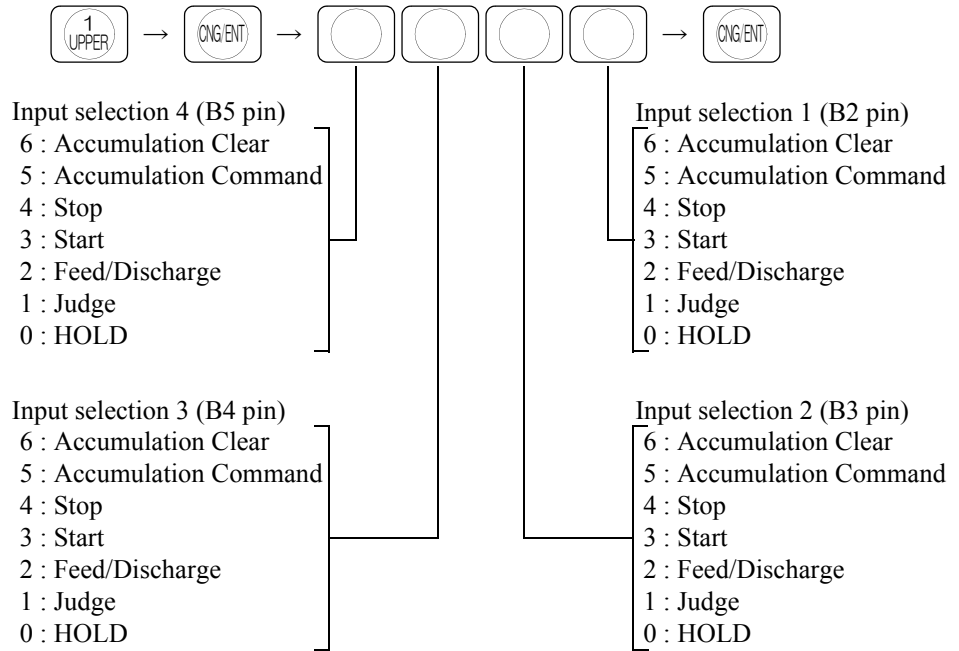

Accumulation command through the RS-232C or RS-485 (option)

An immediate accumulation is executed when the accumulation command “CI” is received from the host.

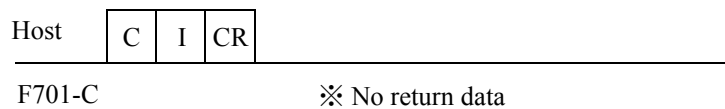

Accumulation command through the CC-Link (option)

Accumulation is executed by using the bit of RY0018 *.
 Accumulation is executed by ON edge.

* When occupied 4 or 2stations. When 1 station is occupied, RY0008 is used.

7-3. Accumulation Clear

Clear Accumulated Data (times, accumulation value and statistical data).

Operation

1) Select setting mode 9.

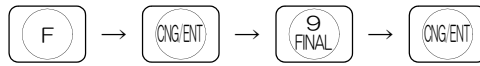

2) Input the password "1235". (9-Pass Word)



Accumulations can be cleared by the password input or external input/output signal or through the RS-232C, RS-485 (option), CC-Link (option).

Accumulation clear by the external input/output

Set one of the B2 to 5 pins out of the external input/output signals to "accumulation clear".

Immediate accumulation clearing is executed at the ON edge of an input to the set pin.

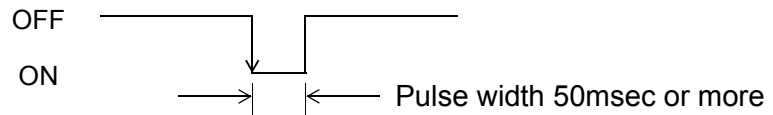

Operation

1) Select setting mode 5.

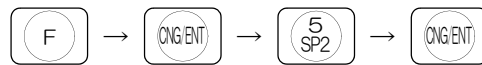

2) One of input selections 1~4 is set to the Accumulation Clear. (1-Input Selection)

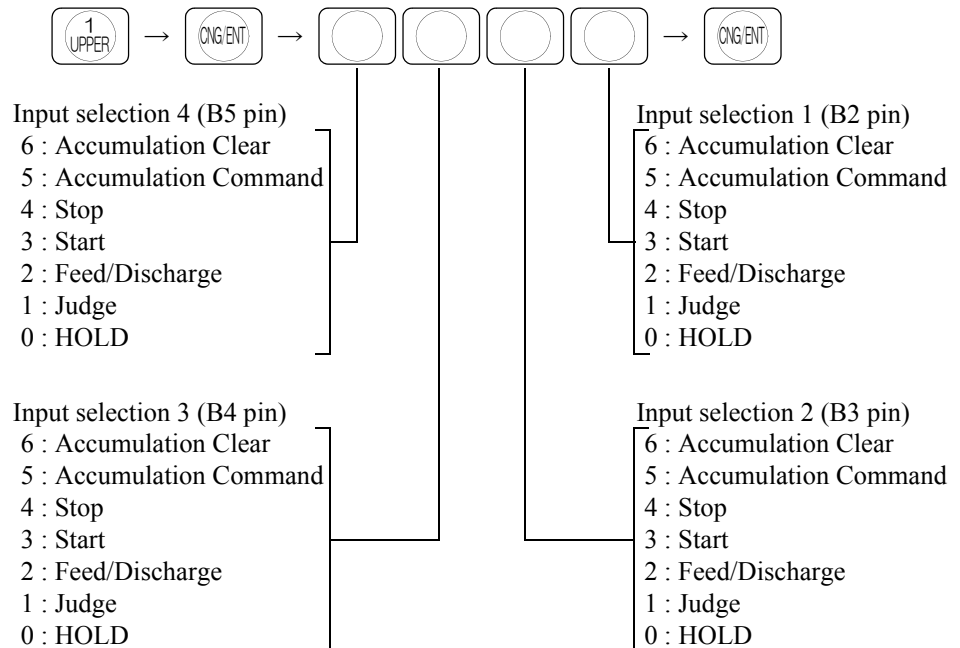

Accumulation clear through the RS-232C or RS-485 (option)

Immediate accumulation clearing is executed when the accumulation command “CJ” is received from the host.

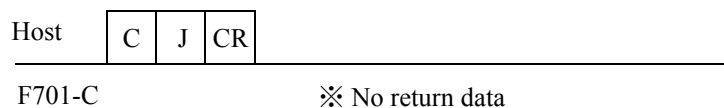

Accumulation clear through the CC-Link (option)

Accumulation clearing is executed by using the bit of RY0019 *.
 Accumulation clearing is executed by ON edge.

* When occupied 4 or 2stations. When 1 station is occupied, RY0009 is used.

7-4. Auto Accumulation Command

Select whether or not to automatically accumulate weight values in the F701-C. If the auto accumulation command is on, an accumulation is made when the complete signal of the F701-C turns on. At this time, the count, accumulation value and statistical data are updated, and also an auto print command is sent onto the SI/F format.

However, in the case where the result of weighing is negative or in the case of “over scale”, no accumulation is made if no judgment is set.

Auto accumulation command timing

1) Simple comparison command

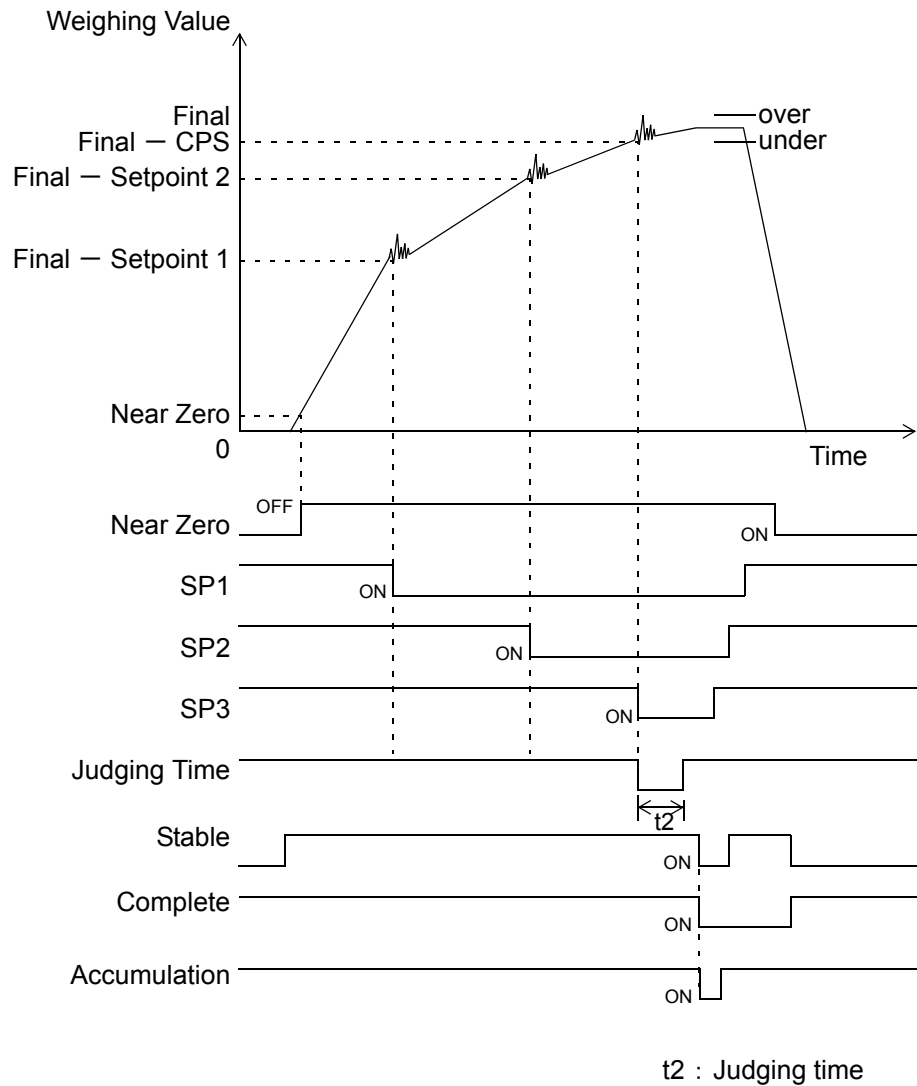

2) Sequence control

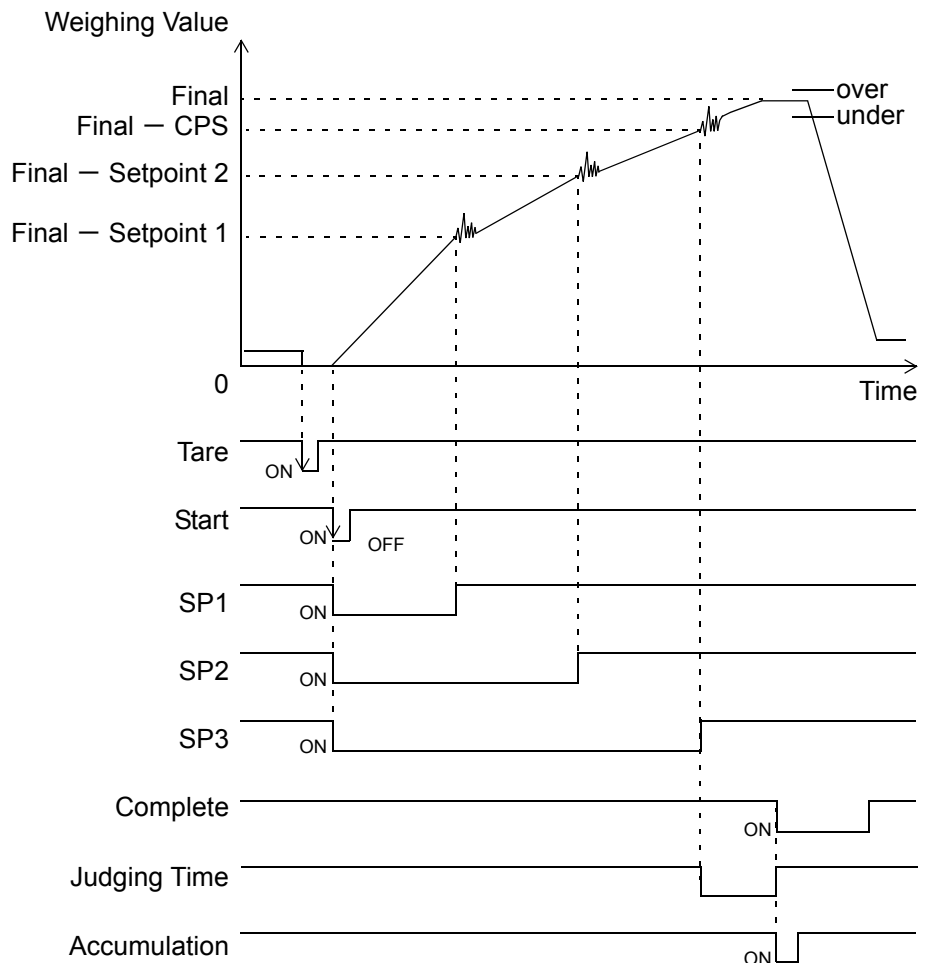

Regarding Simple Comparison Control and Sequence Control refer to "6-2.Simple Comparison Control and Sequence Control" on P.75.

Operation

1) Select setting mode 2.

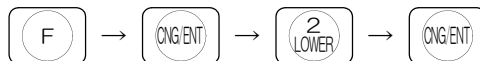

2) Set whether the auto accumulation command is ON or OFF. (2-Weighing Function 2)



Accumulation command selection
 1 : Auto accumulation command ON
 0 : Auto accumulation command OFF

8. SYSTEM MODE

8-1. LOCK (soft)

Lock for protecting from false operation, refer to "18.THE LIST OF INITIAL SETTING VALUE" on P.173 regarding effective setting value for LOCK (soft).

Select from ON/OFF.

Operation

1) Select setting mode 4.

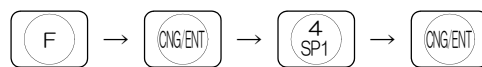

2) Select LOCK1 and LOCK2 ON/OFF. (8-Setting Value LOCK)

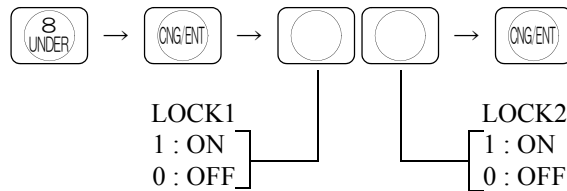

8-2. Password

Use for clearing statistical data in setting mode 8.

Operation

1) Select setting mode 9.

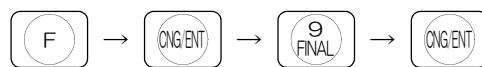

2) Input the password "1235". (9-Pass Word)



8-3. Self-Check and Memory Clear

This equipment is provided with the self-check function by which the memory is automatically checked to detect problems, and the visual check function by which the display can be checked visually.

While pressing the  key, turn ON the power.

With this, checking starts immediately.

	Description	Type	
1	Software version	Display	
2	All lighting on the display	Display	
3	RAM Read/Write Check	Auto	← E r r o r 1 is displayed when error occurs.
4	ROM check sum Check	Auto	← E r r o r 2 is displayed when error occurs.
5	Status sequential lighting	Visual	
6	7-segment lighting on the display	Visual	
7	NOV RAM Read/Write Check	Auto	← E r r o r 3 is displayed when error occurs.
	PASS display and check end	Display	

※ The software version display may vary according to the time of purchase.



※ When the LOCK switch on the rear panel is ON, the NOV RAM is not checked.

※ Visually check the display.

※ Checking stops when there is any problem during memory checks.

※ If checking in progress stops or the display is not correct, it is faulty. Ask our agency or us for repair.

● Memory clear

While pressing the  and  keys, turn ON the power, so that the memory (SRAM) (setting values and work areas) is cleared, and the self-check program is executed.

(ALL CLR (ALL CLr) is displayed.)

※ However, the settings and calibrated values stored in the NOV RAM (nonvolatile RAM) remain unchanged. (Refer to "18.THE LIST OF INITIAL SETTING VALUE" on P.173.)

9. EXTERNAL INPUT/OUTPUT SIGNALS (CONTROL CONNECTOR)

The Input/Output circuit and internal circuit are photocoupler-insulated electrically.

9-1. Control Connector-Pin Assignment

The applicable connector is the following (accessory) manufactured by Fujitsu Component or an equivalent:

Connector: FCN-361J024-AU / Cover: FCN-360C024-B

A1	*	COM	B1	*	COM
A2	In	G/N	B2	In	Input Selection 1 *1
A3	In	D/Z ON	B3	In	Input Selection 2 *1
A4	In	Tare ON	B4	In	Input Selection 3 *1
A5	In	Tare OFF	B5	In	Input Selection 4 *1
A6	Out	Near Zero	B6	Out	Lower Limit
A7	Out	SP1	B7	Out	Upper Limit
A8	Out	SP2	B8	Out	Stable
A9	Out	SP3	B9	Out	Output Selection 1 *2
A10	Out	Under	B10	Out	Output Selection 2 *2
A11	Out	Over	B11	Out	Output Selection 3 *2
A12	*	COM	B12	*	COM

※ * : The COM (common) terminals are connected inside.

※ *1 : Selectable by setting. (For details, please refer to "9-4-11.Input Selection" on P.115)

※ *2 : Selectable by setting. (For details, please refer to "6-10.Weight Error / Sequence Error" on P.99, "6-7.Complete Signal Output Mode / Complete Output Time / Judging Time / Comparison Inhibit Time / Output Selection 2" on P.91, "9-5-7.Accumulation Error" on P.117)

※ SP1 turns ON when Weight value \geq Final - SP1

SP2 turns ON when Weight value \geq Final - SP2

SP3 turns ON when Weight value \geq Final - CPS

9-2. Equivalent Circuit (Input)

A signal is inputted to the signal input circuit by short-circuiting or opening the input terminal and the COM terminal. Short-circuiting is effected by means of a contact (such as a relay or a switch) or a noncontact (such as a transistor or an open-collector TTL).

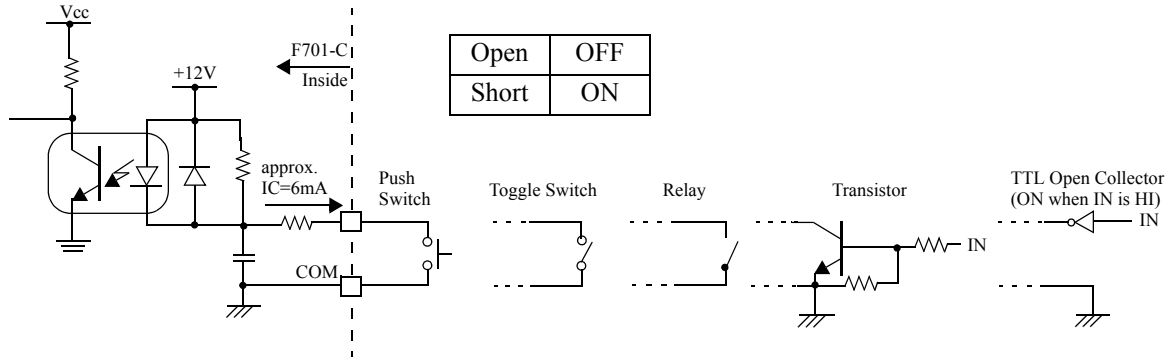

- Do not apply external voltage to the signal input circuit.
- The external element is required to withstand $I_c=10\text{mA}$.
- Leakage from the external element is required to be $100\ \mu\text{A}$ or below.

9-3. Equivalent Circuit (Output)

The signal output circuit is open-collector output of a transistor.

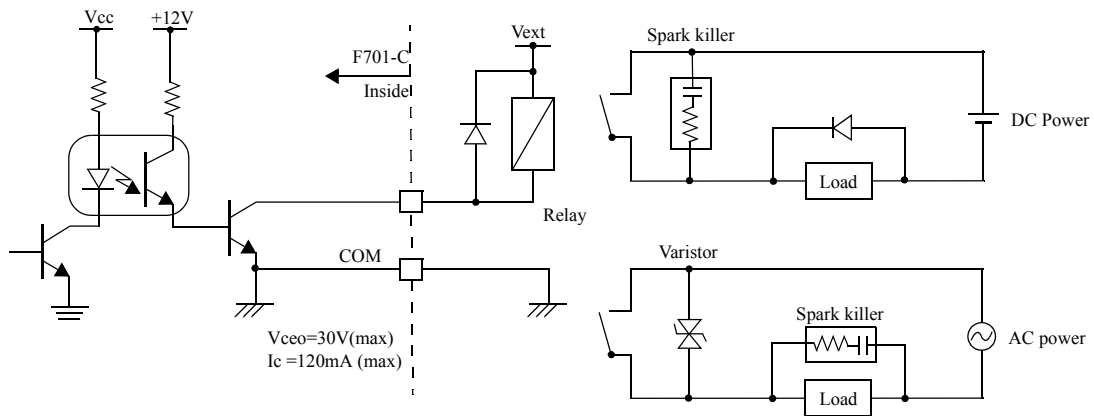

• Transistor status

Output data	Tr
0	OFF
1	ON

- Use external power source (up to DC30V) for driving relay (V_{ext}).
- Do not short-circuit the load, such as a coil of relay, that will break the output transistor.
- Connect a surge absorber or a spark killer to the relay circuit as shown in the draft so that to reduce noise trouble and extend the life of relay. Noise trouble can be reduced, and the relay's life can be extended.

9-4. External Input Signal

9-4-1. Gross/Net Switching (G/N) <Edge Input> <Level Input>

Edge input or level input is selectable by the setting of Gross weight/Net weight display (External Function Selection in setting mode 4).

※ For the method of setting, refer to "5-15.Switching Gross Weight/Net Weight Display" on P.66.

• In the case of edge input (G/N setting: internal key mode)

When external input is ON edge (OFF → ON), display switches to Net weight.

When external input is OFF edge (ON → OFF), display switches to Gross weight.



• In the case of level input (G/N setting: external input mode)

Net weight display results at ON, and Gross weight display results at OFF.

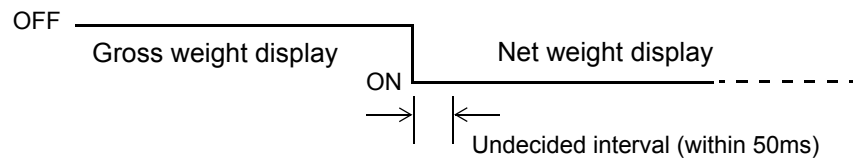



9-4-2. Digital Zero (D/Z ON) <Edge Input>

When external input is ON edge (OFF → ON), it brings the Gross weight to zero.

This function works within the range of DZ Regulation Value.

If out of this range, zero will not result, but “ \overline{ZALM} ” flashes.

The  →  key operation also results in the same movement (when the ZERO key is valid under the Function Key Invalid setting in setting mode 2).

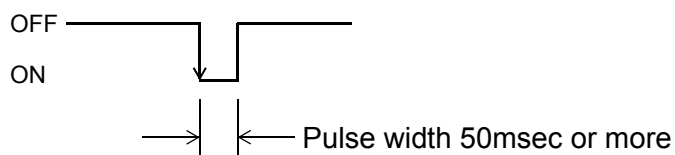

9-4-3. Tare Subtraction (TARE ON) <Edge Input>

Subtract the Tare at once by external input ON edge (OFF → ON), it brings the Net weight to zero. The  key operation also results in the same movement (when [TARE] key is valid under the Function Key Invalid setting in setting mode 2)

However, the operation is performed only when “ $\overline{\text{STAB}}$ ” is on depending on the setting of Restriction on the Tare Subtraction Function in setting mode 4. The range of Tare subtraction can be selected from all range or $0 < \text{Tare} \leq \text{Capacity}$.

※ During Tare subtraction, “ $\overline{\text{TARE}}$ ” lights.

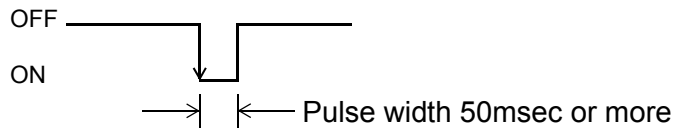

9-4-4. Tare Subtraction Reset (TARE OFF) <Edge Input>

Reset the Tare by external input edge (OFF → ON).

This does not apply to Tare Weight.

The  key operation also results in the same movement (when [TARE RESET] key is valid under the Function Key Invalid setting in setting mode 2)

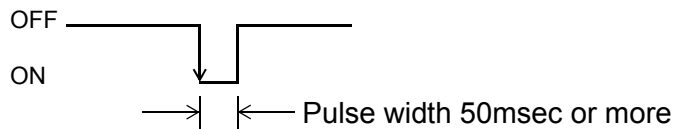

9-4-5. Hold (HOLD) <Level Input>

The weight value and comparison will be in a hold mode while external input is ON.

※ “ $\overline{\text{HOLD}}$ ” blinks in a hold mode.

※ Hold function is ineffective in Sequence Mode.

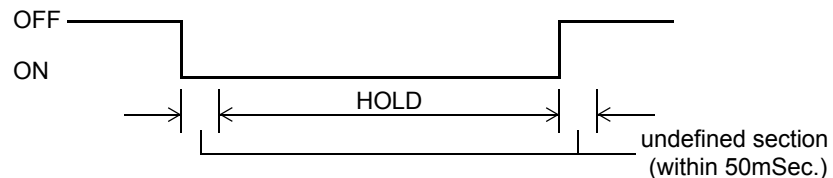

9-4-6. Judge <Level Input>

Valid when Over/Under comparison or Upper/Lower limit comparison (Weighing Function 2 in setting mode 2) is set to external judgment input.

※ For the method of setting, refer to "6-6.Upper/Lower Limit Comparison / Upper/Lower Limit Comparison Mode / Near Zero Comparison / Final and Comparison / Over/Under Comparison Mode" on P.89.

※ Judge function is ineffective in Sequence Mode.

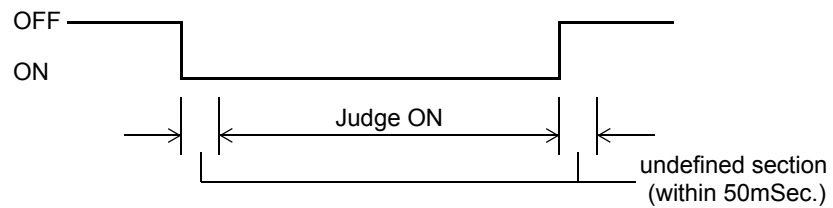

9-4-7. Feed / Discharge <Level Input>

Discharging control mode (Weighing Function 1 in setting mode 2) is effective in external selection.

※ For the method of setting, refer to "6-1-3.Discharging Mode" on P.74.

Feeding control is activated when it is OFF. Discharging control is activated when it is ON.

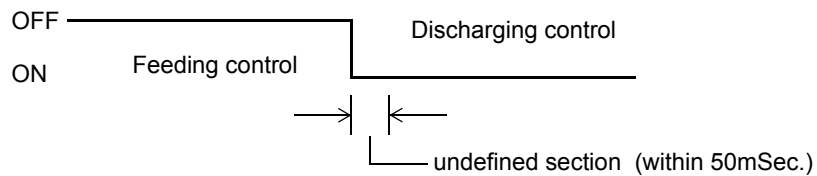

9-4-8. Input Signals Used in Sequence Mode

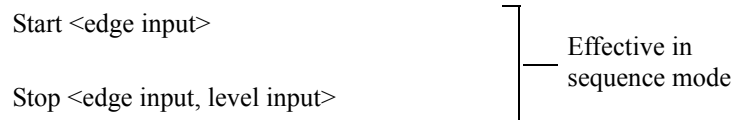

※ For the method of setting, refer to "6-2-3.Sequence Mode" on P.81.

9-4-9. Accumulation command <Edge Input>

An immediate accumulation is executed at the ON edge (OFF → ON) of the external input.

The weight value (gross or net) set in the over/under comparison mode is accumulated.

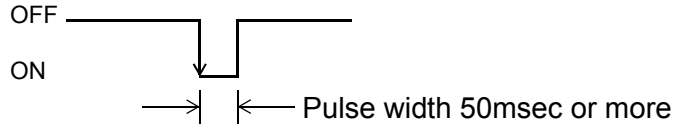

9-4-10. Accumulation Clear <Edge Input>

Immediate clearing of accumulated data and statistical data is executed at the ON edge (OFF → ON) of the external input.

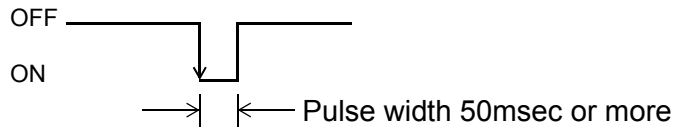

9-4-11. Input Selection

On each pin of input selection 1 (B2) to 4 (B5) of the external input/output signals, the input signal can be selected by setting.

Settable items are accumulation clear, accumulation command, stop, start, feed/discharge, judge, and hold (common to input selection 1 to 4).

However, except the hold signal, the same signal cannot be selected on two or more pins. If the same signal is selected on two or more pins, forced setting of “HOLD” will result. When “HOLD” is selected on two or more pins, the weight value is held if at least one signal is ON.

Operation

1) Select setting mode 5.

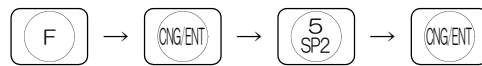

2) Set the Input selection items. (1-Input Selection)

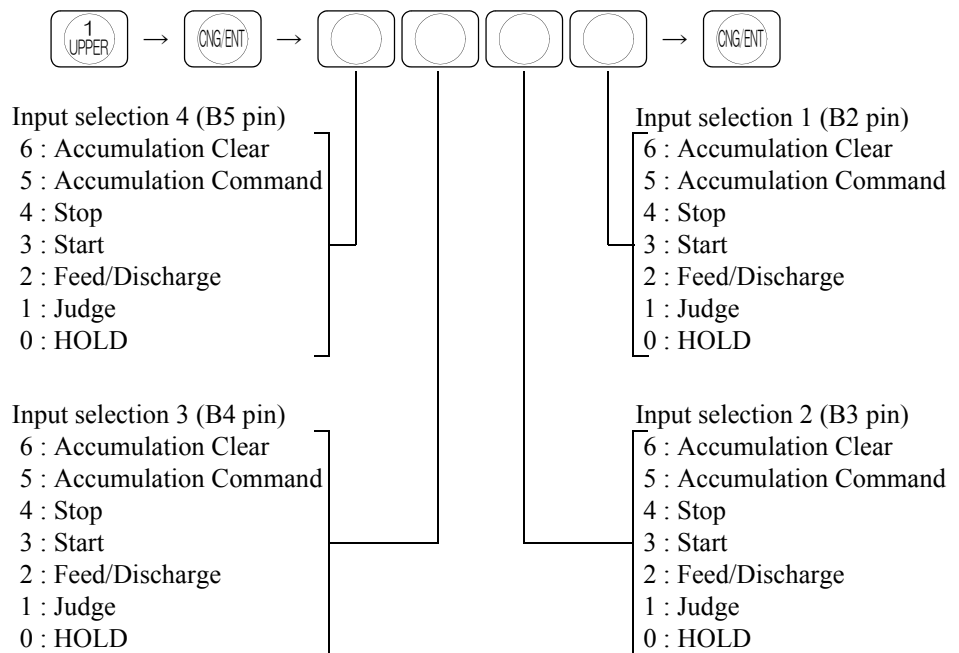

9-5. External Output Signal

9-5-1. Near Zero

The output turns ON when $\text{Weight value} \leq \text{Set value of Near Zero}$.

※ For the method of setting, refer to "6-5.Near Zero / Upper Limit / Lower Limit" on P.88, "6-6.Upper/Lower Limit Comparison / Upper/Lower Limit Comparison Mode / Near Zero Comparison / Final and Comparison / Over/Under Comparison Mode" on P.89.

9-5-2. Lower Limit, Upper Limit

Select from comparison regularly or comparison at external judging ON in Upper/Lower limit comparison mode.

Conditional expression

The lower limit output turns ON when $\text{Weight value} < \text{Lower Limit}$

The upper limit output turns ON when $\text{Weight value} > \text{Upper Limit}$

※ For the method of setting, refer to "6-5.Near Zero / Upper Limit / Lower Limit" on P.88, "6-6.Upper/Lower Limit Comparison / Upper/Lower Limit Comparison Mode / Near Zero Comparison / Final and Comparison / Over/Under Comparison Mode" on P.89.

9-5-3. Stable

This output turns ON when the weight value is stable.

※ Refer to "5-6.Motion Detection (MD)" on P.57 for details.

9-5-4. Weight Error

When the display is LOAD, OFL or ZALM, the output turns ON.

※ For the method of setting, refer to "6-10.Weight Error / Sequence Error" on P.99.

※ For the error display, refer to "11.OVER SCALE & ERROR" on P.155.

9-5-5. Sequence Error

When the display is Err, the output turns ON.

※ For the method of setting, refer to "6-10.Weight Error / Sequence Error" on P.99.

※ For the error display, refer to "11.OVER SCALE & ERROR" on P.155.

9-5-6. RUN

This output turns ON when F701-C is ready to operate.

RUN can be outputted externally as the signal of output selection 3 by setting.

Operation

1) Select setting mode 5.

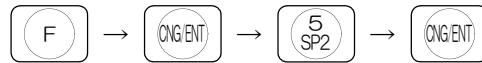

2) Set Output selection 3. (2-Output Selection)

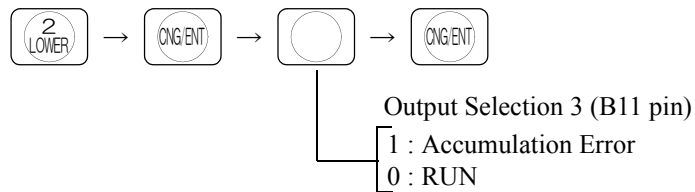

9-5-7. Accumulation Error

The output turns ON when the number of accumulations is 10000.

The accumulation error can be outputted externally as the signal of output selection 3 by setting.

※ For the method of setting, refer to "9-5-6.RUN" on P.117.

※ For the accumulation error, refer to "7.STATISTICAL AND ACCUMULATION FUNCTION SETTING AND OPERATION" on P.100.

9-5-8. SP1, SP2, SP3

◆ **In simple comparison mode**

SP1 turns ON when $\text{Weight value} \geq \text{Final} - \text{SP1}$

SP2 turns ON when $\text{Weight value} \geq \text{Final} - \text{SP2}$

SP3 turns ON when $\text{Weight value} \geq \text{Final} - \text{CPS}$

Final, Set Point 1, Set Point 2, Compensation
in setting mode 0

Final and Over/Under comparison under Weighing Function 1
in setting mode 2

※ For the method of setting, refer to "6-4.Final / Set Point 2 / Set Point 1 / Compensation / Over / Under" on P.85, "6-6.Upper/Lower Limit Comparison / Upper/Lower Limit Comparison Mode / Near Zero Comparison / Final and Comparison / Over/Under Comparison Mode" on P.89.

◆ **In sequence mode**

In sequence mode, the weighing sequence is started at the ON edge of the start signal (OFF → ON), Set Point 1, Set Point 2 and Set Point 3 turn ON.

SP1 turns OFF when $\text{Weight value} \geq \text{Final} - \text{SP1}$

SP2 turns OFF when $\text{Weight value} \geq \text{Final} - \text{SP2}$

SP3 turns OFF when $\text{Weight value} \geq \text{Final} - \text{CPS}$

Final, Set Point 1, Set Point 2, Compensation
in setting mode 0

Final and Over/Under comparison under Weighing Function 1
in setting mode 2

※ For the method of setting, refer to "6-4.Final / Set Point 2 / Set Point 1 / Compensation / Over / Under" on P.85, "6-6.Upper/Lower Limit Comparison / Upper/Lower Limit Comparison Mode / Near Zero Comparison / Final and Comparison / Over/Under Comparison Mode" on P.89, "9-4-11.Input Selection" on P.115.

9-5-9. Under, Go, Over

◆ In simple comparison mode

Select comparison mode in Over/Under comparison mode (Weighing Function 2 in setting mode 2).

The under signal turns ON when $\text{Weight value} < \text{Final} - \text{Under}$

The over signal turns ON when $\text{Weight value} > \text{Final} + \text{Over}$

Final, Under, Over in setting mode 0

Final and Over/Under comparison under Weighing Function 1 in setting mode 2

The go signal turns ON when $\text{Final} + \text{Over} \geq \text{Weight value} \geq \text{Final} - \text{Under}$

※ For the method of setting, refer to "6-4.Final / Set Point 2 / Set Point 1 / Compensation / Over / Under" on P.85, "6-6.Upper/Lower Limit Comparison / Upper/Lower Limit Comparison Mode / Near Zero Comparison / Final and Comparison / Over/Under Comparison Mode" on P.89, "6-7.Complete Signal Output Mode / Complete Output Time / Judging Time / Comparison Inhibit Time / Output Selection 2" on P.91.

◆ In sequence mode

Compares the weight value when complete signal ON and hold it, while ignoring the setting of Over/Under comparison mode (Weighing Function 2 in setting mode 2).
(only when judge ON)

The under signal turns ON when $\text{Weight value} < \text{Final} - \text{Under}$

The over signal turns ON when $\text{Weight value} > \text{Final} + \text{Over}$

Final, Under, Over in setting mode 0

Final and Over/Under comparison under Weighing Function 1 in setting mode 2

The go signal turns ON when $\text{Final} + \text{Over} \geq \text{Weight value} \geq \text{Final} - \text{Under}$

※ The go output signal is used for complete output by setting.
(Either go or complete is selectable.)

※ For the method of setting, refer to "6-4.Final / Set Point 2 / Set Point 1 / Compensation / Over / Under" on P.85, "6-6.Upper/Lower Limit Comparison / Upper/Lower Limit Comparison Mode / Near Zero Comparison / Final and Comparison / Over/Under Comparison Mode" on P.89, "6-7.Complete Signal Output Mode / Complete Output Time / Judging Time / Comparison Inhibit Time / Output Selection 2" on P.91.

9-5-10. Complete**◆ In simple comparison mode**

Select the complete signal output timing in complete signal output mode (Weighing Function 2 in setting mode 2).

The output ON time depends on the Complete Output Time in setting mode 1.

※ For the method of setting, refer to "6-7.Complete Signal Output Mode / Complete Output Time / Judging Time / Comparison Inhibit Time / Output Selection 2" on P.91.



- Unless the weight value once drops down to 25% or less of the Final after the complete output, the complete output will not turn ON after the next weighing.
- If the Final is set at 0, the complete output may turn ON at power-on.

◆ In sequence mode

- With Over/Under judgment

Conditions: The setting of Final and Over/Under comparison is other than "comparison OFF".

The number of Judging Times is other than 0.

Select the complete signal output timing in complete signal output mode (Weighing Function 2 in setting mode 2).

The output ON time depends on the Complete Output Time in setting mode 1.

- Without Over/Under judgment

Conditions: The setting of Final and Over/Under comparison is "comparison OFF".

The number of Judging Times is 0.

The complete output turns ON in defiance of the setting of complete signal output mode (Weighing Function 2 in setting mode 2) on the OFF edge (ON → OFF) of the set point 3 signal.

The output ON time depends on the Complete Output Time in setting mode 1.

※ The complete output signal is used for go output by setting (output selection 2 under Output Selection in setting mode 5).

(Either go or complete is selectable.)

※ For the method of setting, refer to "6-7.Complete Signal Output Mode / Complete Output Time / Judging Time / Comparison Inhibit Time / Output Selection 2" on P.91.

9-5-11. Output selection

Each signal of the weight error, sequence error, complete, go, RUN, and accumulation error outputs is selective by setting.

Weight error and sequence error

The weight error and sequence error are outputted from output selection 1 of B9 pin.

Complete and Go

The complete and go are outputted from output selection 2 of B10 pin.

RUN and accumulation error

The RUN and accumulation error are outputted from output selection 3 of B11 pin.

Operation

1) Select setting mode 5.

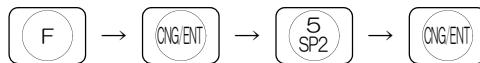

2) Set the Output selection 1, 2 and 3. (2-Output Selection)

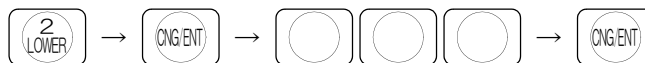

Output selection 3 (B11 pin)
 1 : Accumulation Error
 0 : RUN

Output selection 1 (B9 pin)
 2 : Weight error
 or sequence error
 1 : Sequence error
 0 : Weight error

Output selection 2 (B10 pin)
 1 : Complete output
 0 : Go output

10. INTERFACE

10-1. 2-wire Serial Interface (S/I/F)

This 2-wire serial interface is for connecting the F701-C to peripheral equipment such as a printer or remote display. A two-core parallel cable or a cabtyre cable (Wire with covering thickened for construction) may be used for connection. When a two-core parallel cable or a cabtyre cable is used, the transmitting distance is approximately 30m. When a two-core shielded twisted pair cable is used, the transmitting distance is approximately 300m.

10-1-1. Connection

Up to three nonpolarized external devices can be connected. It should not run along side AC or other high-voltage wiring. It may cause of malfunction.

Example 1 :

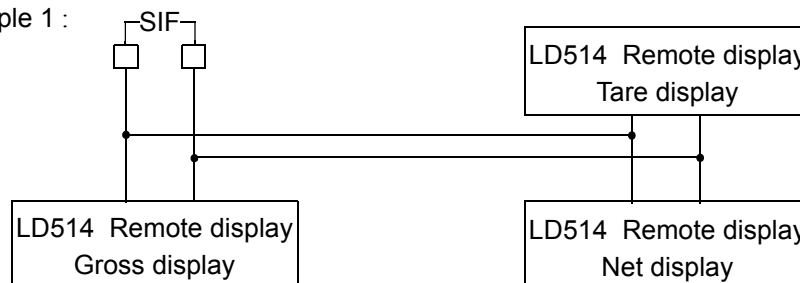

※ Up to 3 remote displays (LD514) can be connected. The each display (Gross weight, Net weight, Tare weight) can display individual content according to the selection.

Example 2 :

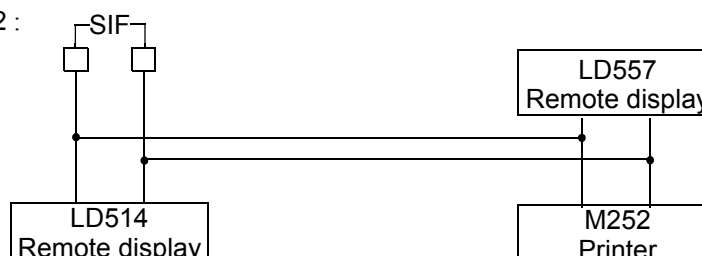

※ These indicated above are examples for the connection of remote displays (LD557, LD514, M252). Each display can select the data (Gross weight, Net weight, Tare weight) individually.

10-1-2. Auto Print Command

The F701-C gives an auto print command to any device connected by SI/F interface. In sequence mode, the auto print command is output when the judgment signal (Go, Over, Under) turns ON. Therefore, be aware that the auto print command is not output when no judgment is set (Judging Times = 00). In simple comparison mode, the auto print command is output when the complete signal turns ON. Therefore, the auto print command is not output when the setting of Final and Over/Under comparison is comparison OFF (Weighing Function 1 in setting mode 2). An auto print command is outputted to the external device when the accumulation command is received by the external input/output signal or through the RS-232C, RS-485 (option), CC-Link (option).

10-2. RS-232C Interface

10-2-1. Communication Specifications

1.Specifications

Signal level	:	Based on the RS-232C
Transmitting distance	:	Approx. 15m (16.4yd.)
Transmitting method	:	Asynchronous, full duplex
Transmitting speed	:	1200, 2400, 4800, 9600, 19200 or 38400 bps selectable
Bit configuration	:	Start 1 bit Character length 7 or 8 bits selectable Stop 1 or 2 bits selectable Parity none, odd or even selectable
Code	:	ASCII

2.Connector pin assignment

Adaptable connector : 9-pin D-SUB connector
(JAE DE-09SN, OMRON XM2D-0901 etc)

1			6		
2	In	RXD	7	Out	RTS
3	Out	TXD	8	In	CTS
4			9		
5	*	GND			

10-2-2. Cable

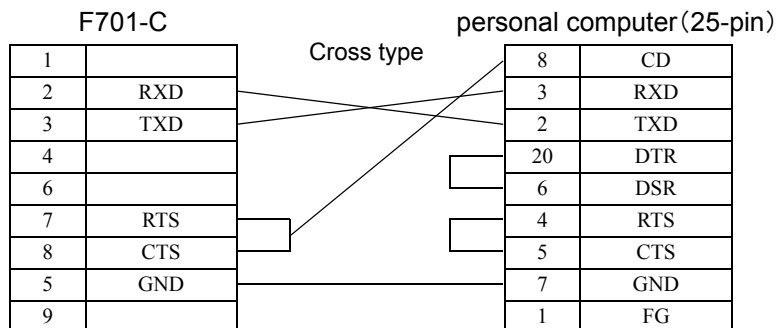
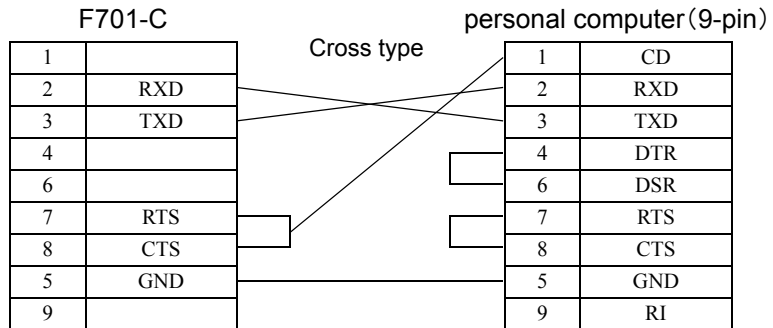

The above diagram is for connecting a personal computer as a DTE (Data Terminal Equipment) device. If it is a DCE (Data Circuit-terminating Equipment) device, connect pin to pin (DTR to DTR, DSR to DSR etc.).

Cables should be prepared after checking connector type and pin assignments of the connected device.

10-2-3. Setting Values for RS-232C

1. Set the RS-232C port of this equipment.

Operation

1) Select setting mode 4.

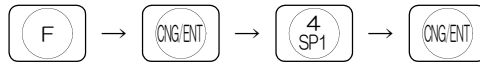

2) Set the RS-232C port. (6-RS-232C I/F)

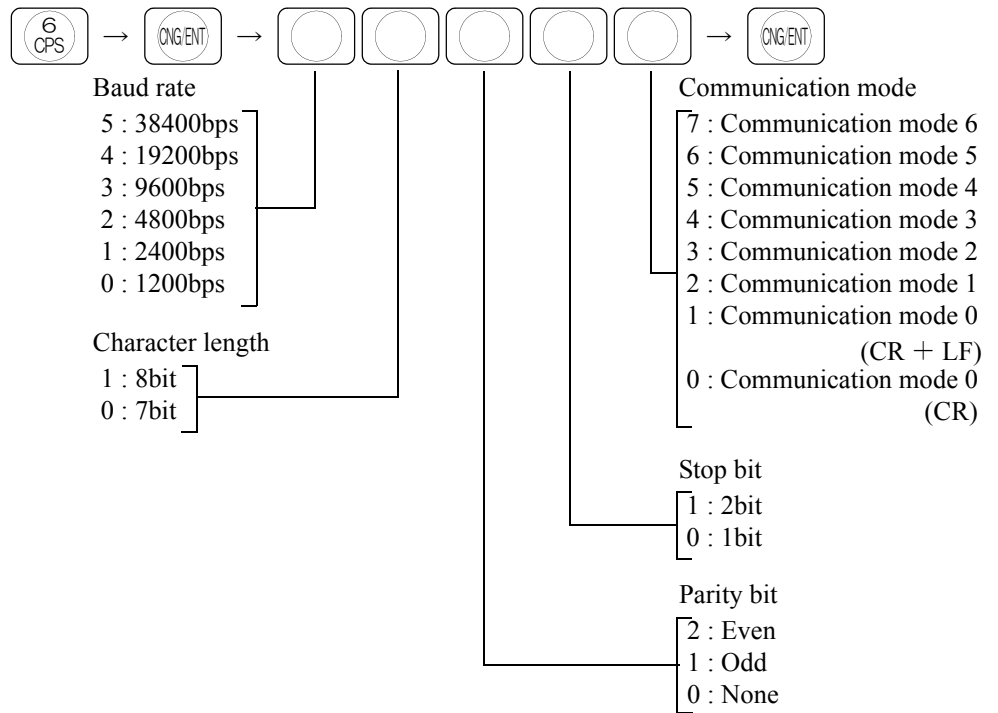

2. The initial set for RS-232C port of connecting personal computer and sequencer should be the same setting of F701-C.

10-2-4. Communication Mode

• Communication mode 0

F701-C communicates with the command from the host computer.
The terminator can be selected “CR” or “CR+LF”.

• Communication mode 1

F701-C sends Gross weight continuously.
Command is invalid at this mode.

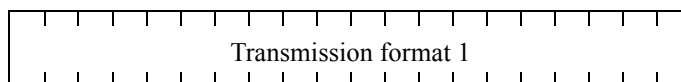

(20byte)

▪ **Communication mode 2**

F701-C sends Net weight continuously.
 Command is invalid at this mode.

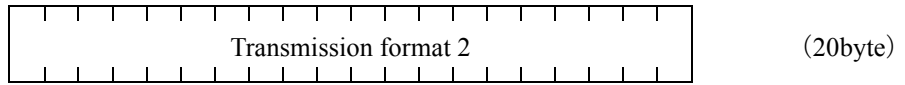

▪ **Communication mode 3**

F701-C sends Gross and Net weight continuously.
 Command is invalid at this mode.

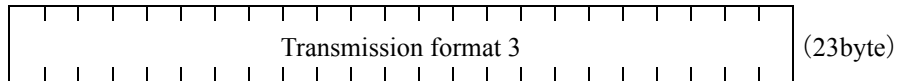

▪ **Communication mode 4**

F701-C sends Gross weight at the timing of auto print command.
 Command is invalid at this mode.

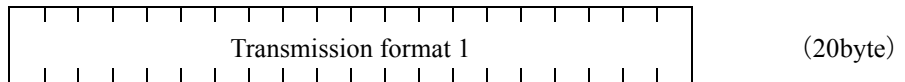

▪ **Communication mode 5**

F701-C sends Net weight at the timing of auto print command.
 Command is invalid at this mode.

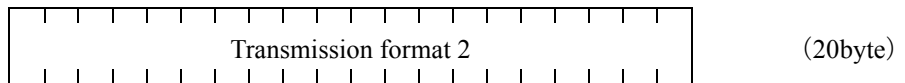

▪ **Communication mode 6**

F701-C sends Gross and Net weight at the timing of auto print command.
 Command is invalid at this mode.

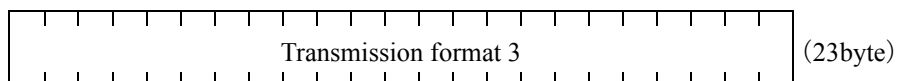

Request

Please refer to each page about following items.

- Transmission format : "10-2-5.Transmission Format" on P.126
- Communication format : "10-2-6.Communication Format" on P.127
- Print Command : "10-1-2.Auto Print Command" on P.122

10-2-5. Transmission Format

• Transmission format 1

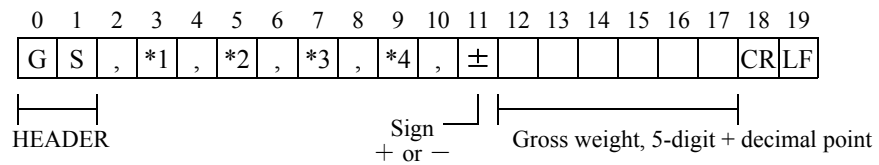

• Transmission format 2

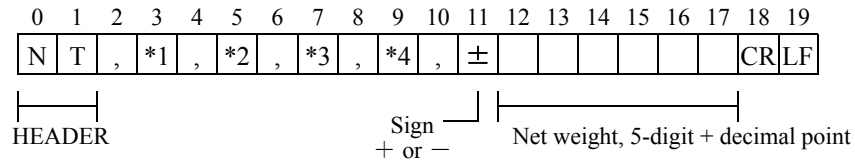

• Transmission format 3

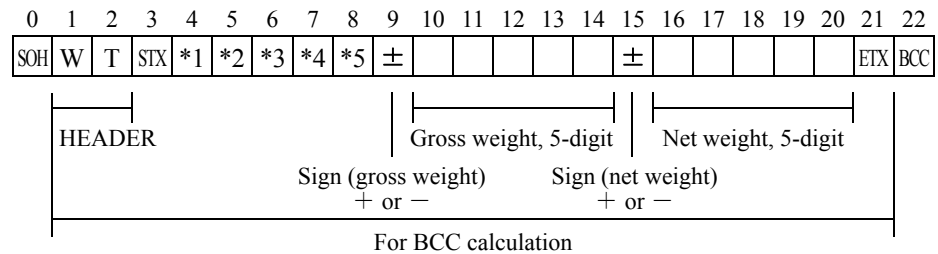

Each ASCII code of SOH,STX and ETX

SOH : 01 STX : 02 ETX : 03

BCC : Block check character

It is calculated as the XOR of the transmitted character (Hexadecimal).

- | | |
|--|--|
| <p>*1 O : Overload (LOAD,OFL)
 S : Stable
 M : Unstable
 H : Hold</p> | <p>*4 N : Near zero OFF
 Z : Near zero ON</p> |
|--|--|

Priority H > O > (S or M)

- | | |
|--|---|
| <p>*2 A : Zero tracking OFF
 T : Zero tracking ON
 Z : Zero error</p> | <p>*5 Decimal place
 3 : 0.000
 2 : 0.00
 1 : 0.0
 0 : 0</p> |
|--|---|

Priority Z > (T or A)

- *3 H : Upper limit ON
 L : Lower limit ON
 G : Upper limit and Lower limit OFF
 N : Upper limit and Lower limit ON
 F : Comparison OFF

Priority N > (H or L)

• Reading out the status 2 (7-digit)

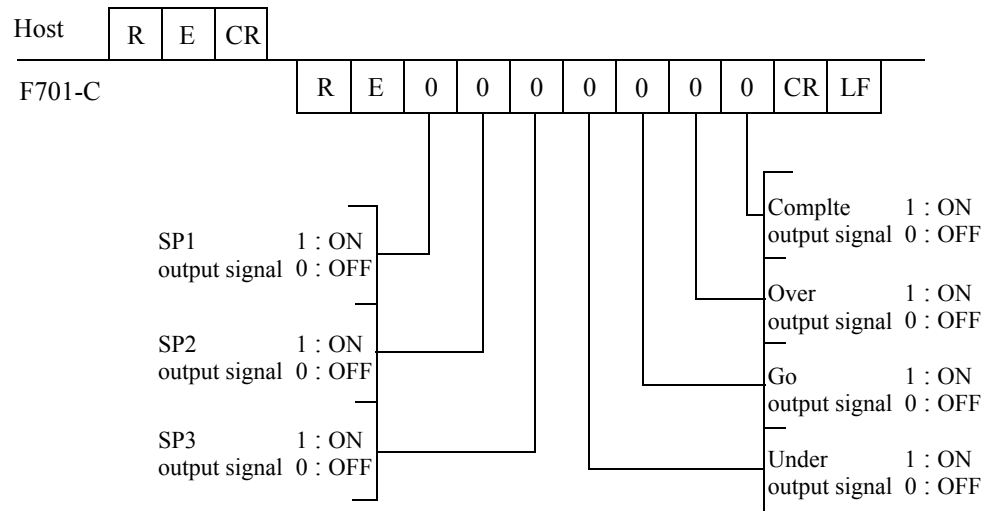

• Reading out the status 3 (7-digit)

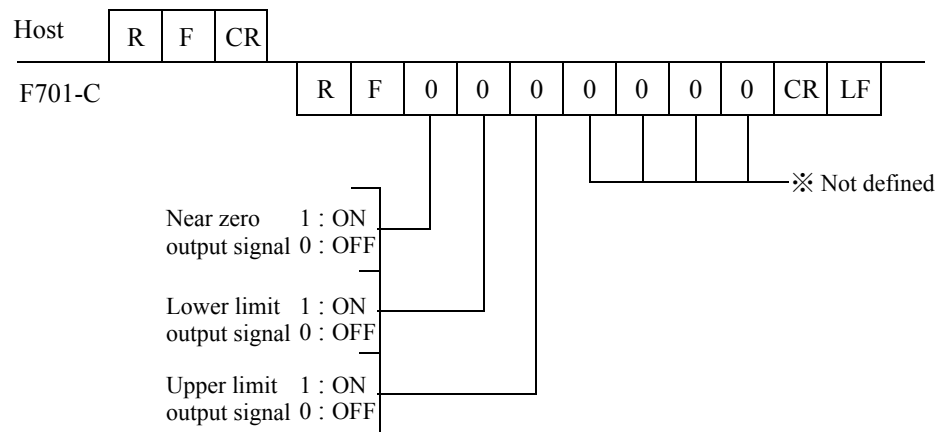

• Reading out the status 4 (7-digit)

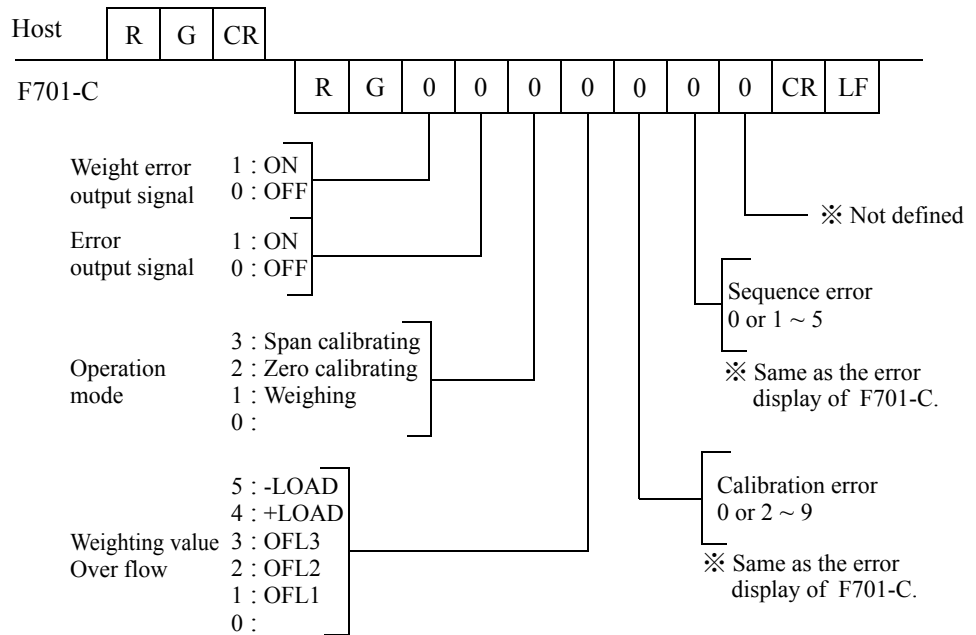

• Read out the count of data (accumulation times : 5-digit)

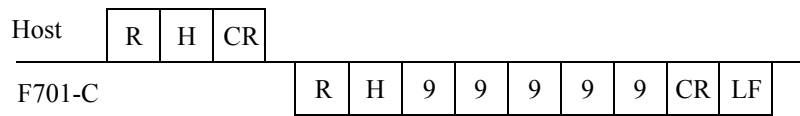

• Read out the accumulated value (9-digit, decimal point)

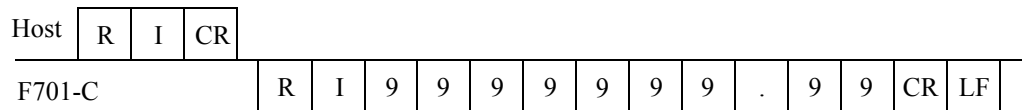

• Read out the accumulated data

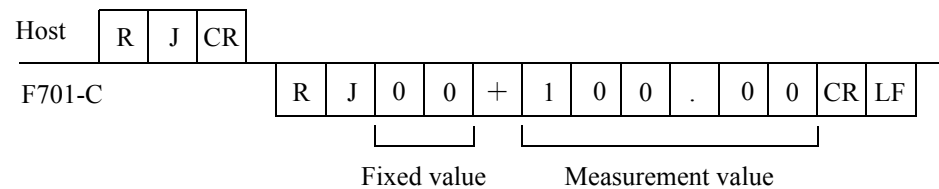

* Up to 256 pieces of data can be stored in the buffer in memory.
 Reading-out erases data chronologically.

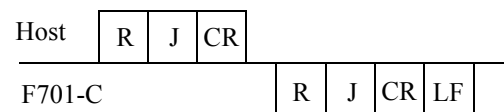

Data returned when there is no accumulated data in the buffer.

• Write in the set value

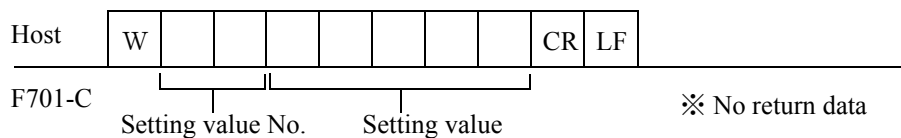

※ For setting value No., refer to "Setting value communication format" on P.132.

• Read out the set value

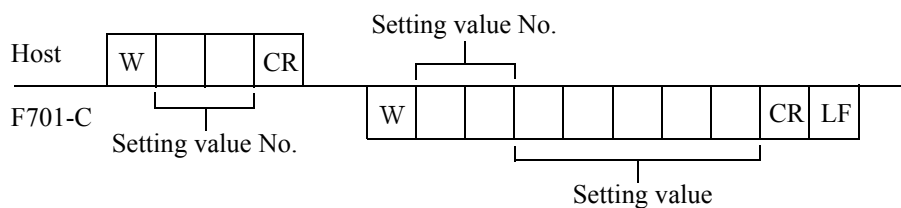

※ For setting value No., refer to "Setting value communication format" on P.132.

• Zero Calibration

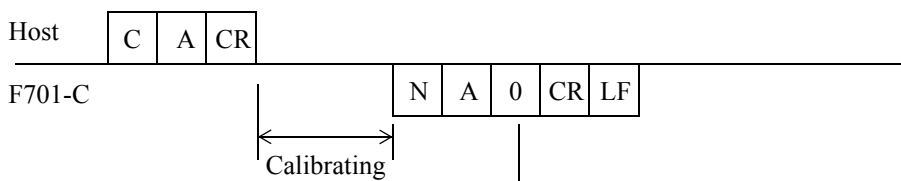

0: Normally completed, 1 ~ 9 : Error
(same as the error display of F701-C)

• Span Calibration

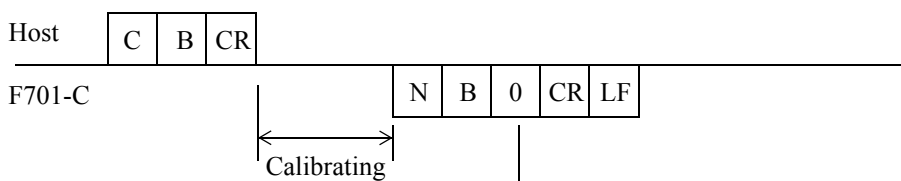

0: Normally completed, 1 ~ 9 : Error
(same as the error display of F701-C)

Request

Zero Calibration • Span Calibration

Before sending this command, set the Capacity, Min. Scale division and Balance Weight Value.

• Gross weight selection

Host	C	C	CR
------	---	---	----

F701-C ※ No return data

• Net weight selection

Host	C	D	CR
------	---	---	----

F701-C ※ No return data

• Tare subtraction

Host	C	E	CR
------	---	---	----

F701-C ※ No return data

• Tare subtraction reset

Host	C	F	CR
------	---	---	----

F701-C ※ No return data

• Digital zero

Host	C	G	CR
------	---	---	----

F701-C ※ No return data

• Digital zero reset

Host	C	H	CR
------	---	---	----

F701-C ※ No return data

• Accumulation Command

Host	C	I	CR
------	---	---	----

F701-C ※ No return data

• Accumulation Clear

Host	C	J	CR
------	---	---	----

F701-C ※ No return data

10-3. BCD Parallel Data Output Interface

The BCD data output is an interface to take out measured weight values as BCD data. It is a convenience to perform processing, such as control, totaling, and recording as connected with a computer, process controller, sequencer, etc. The Input/Output circuit and internal circuit are photocoupler-insulated electrically.

10-3-1. Control Connector-Pin Assignment

Adaptable connector : DDK 57-30360 or equivalent one

1	*	COM	19	*	COM
2	Out	1	20	Out	20000
3	Out	2	21	Out	40000
4	Out	4	22	Out	80000
5	Out	8	23	Out	MINUS
6	Out	10	24	Out	OVER
7	Out	20	25	Out	P.C
8	Out	40	26	Out	STROBE
9	Out	80	27	In	Data hold
10	Out	100	28	In	Logic switching
11	Out	200	29	In	Output selection 1
12	Out	400	30	In	Output selection 2
13	Out	800	31	In	
14	Out	1000	32	In	
15	Out	2000	33	In	
16	Out	4000	34	In	
17	Out	8000	35		
18	Out	10000	36		

* : The COM (common) terminals are connected inside.

10-3-2. Equivalent Circuit (Input)

A signal is inputted to the signal input circuit by short-circuiting or opening the input terminal and the COM terminal. Short-circuiting is effected by means of a contact (such as a relay or a switch) or a noncontact (such as a transistor or an open-collector TTL).

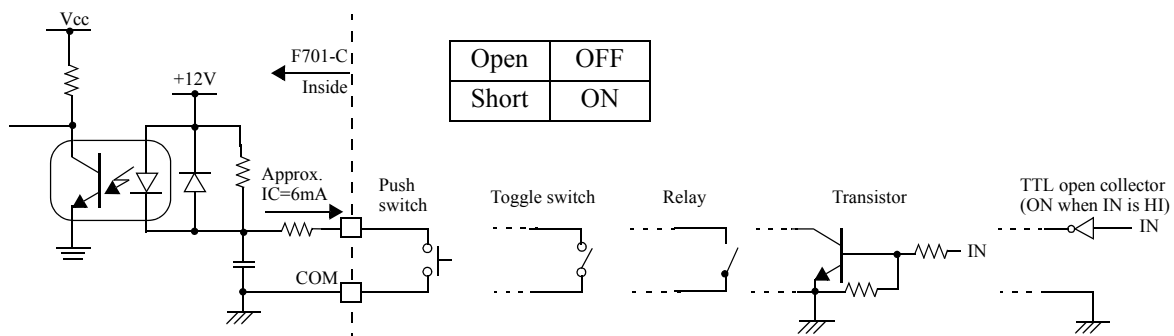

- Do not apply external voltage to the signal input circuit.
- The external element is required to withstand $I_c=10\text{mA}$.
- Leakage from the external element is required to be $100\ \mu\text{A}$ or below.

10-3-3. Equivalent Circuit (Output)

The signal output circuit is open-collector output of TTL.

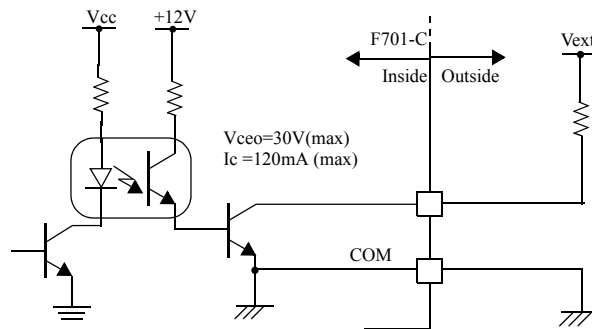

● Internal transistor status

Output data	Negative	Positive
0	OFF	ON
1	ON	OFF

● Output pin level

Output data	Negative	Positive
0	H	L
1	L	H

Through logic switching (pin28)

10-3-4. BCD Data Output

Measured weight values are output in 5-digit BCD. Respective digits are output as 0 and 1 data in 4 bits: 8, 4, 2 and 1.

digit data	8	4	2	1
0	0	0	0	0
1	0	0	0	1
2	0	0	1	0
3	0	0	1	1
4	0	1	0	0
5	0	1	0	1
6	0	1	1	0
7	0	1	1	1
8	1	0	0	0
9	1	0	0	1

10-3-5. Polarity Output (MINUS)

The polarity of weight values output as BCD data is output as follows:

When positive (+): 0

When negative (-): 1

10-3-6. Over Status Output (OVER)

When weight values output as BCD data are on the following conditions, 1 (OVER) is output.

Weight value	Conditional expression	
Net weight	Net weight > Net over setting value	0FL1
Gross weight	Gross weight > Gross over setting value	0FL3
Tare weight	Tare weight > 99999	

10-3-7. Print Command Output (P.C)

For reading data, use the pulse end edge.

It is output in synchronization with the complete signal when judgment is made on Over/Under comparison.

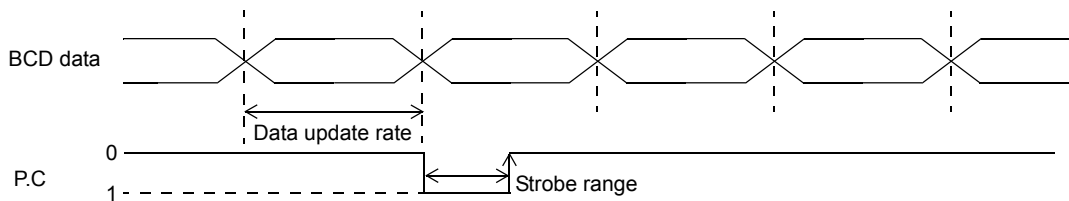

10-3-8. Data Strobe (STROBE)

BCD data is updated at each time of A/D conversion, and strobe pulses are output in synchronization with the BCD data.

For reading data, use the pulse end edge.

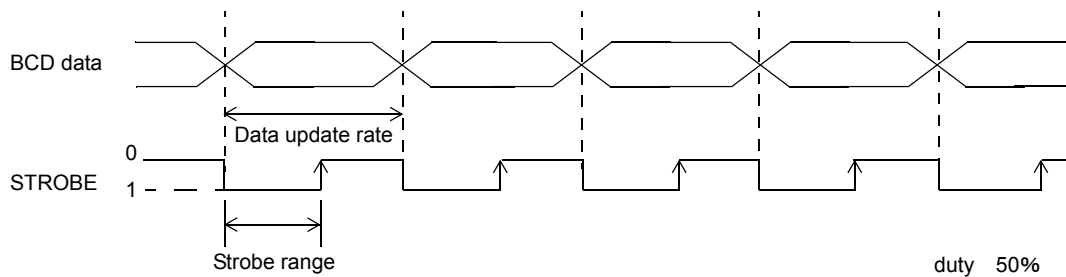

The data update rate is normally 200 times/sec., which is the same as the operating speed of the main unit, but data may not be read with some connected external devices because the speed is too fast. In such a case, set the data update rate longer (reduce the number of times).

10-3-9. BCD Data Update Rate Selection

Operation

1) Select setting mode 4.

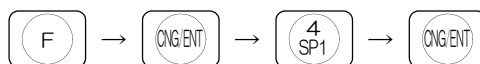

2) Set the Data update rate. (7-External Function Selection)

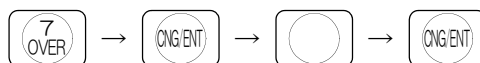

Data update rate

7	: 1 times/sec. STOROB range	Approx. 500msec
6	: 2 times/sec. STOROB range	Approx. 250msec
5	: 5 times/sec. STOROB range	Approx. 100msec
4	: 10 times/sec. STOROB range	Approx. 50msec
3	: 20 times/sec. STOROB range	Approx. 25msec
2	: 50 times/sec. STOROB range	Approx. 10msec
1	: 100 times/sec. STOROB range	Approx. 5msec
0	: 200 times/sec. STOROB range	Approx. 2.5msec

10-3-10. Data Hold Input

When this input terminal is short-circuited with the COM terminal, the BCD data is held.
(No strobe pulses are output.)

10-3-11. Logic Switching Input

The output signal logic is switched.

Open : negative
Short : positive

10-3-12. Output Selection Input

Select weight values to be output as BCD data.

Selection 1	Selection 2	Weight value
Open	Open	Weight value displayed by the main unit
Open	Short	Net weight
Short	Short	Gross weight
Short	Open	Tare weight

10-4. D/A Converter

The D/A converter is an interface to output measured weight values as electrical signals.

Current in proportion to the weight value (4mA ~ 20mA) can be output.

The over range is $\pm 5\%$ of the full scale.

10-4-1. Name of Each Part

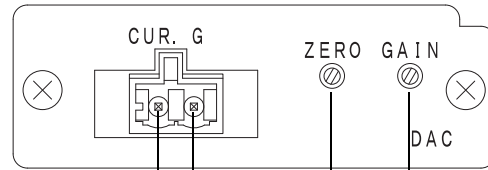

- Gain fine trim potentiometer

For fine adjustment of gain. Trimmer adjusts output to 20.00mA for full scale.

Gain can be adjusted through the front panel as well.

- Zero fine trim potentiometer

For fine adjustment of zero. Trimmer adjusts output to 4.00mA for zero.

Zero can be adjusted through the front panel as well.

- Current output terminals

The terminals for current output of 4 ~ 20mA. Connect an instrument whose load resistance is less than 350 Ω .

Request

The trimmer is for fine adjustment.

Temperature drift may increase if you have severely changed the value that had been set when you first received the product, please adjust it within a range of $\pm 0.2\text{mA}$.

⚠ CAUTION

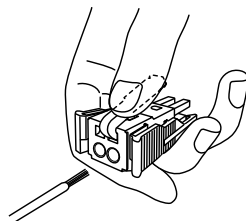

- Pick up the plug then handle the lever with thumb.

- Do not handle the lever when the plug is attached to the base otherwise it may cause some trouble.

• Taking current output signals

Connect an external equipment (load resistance $350\ \Omega$ or less) between CUR.(+) ~ G(-) of F701-C.

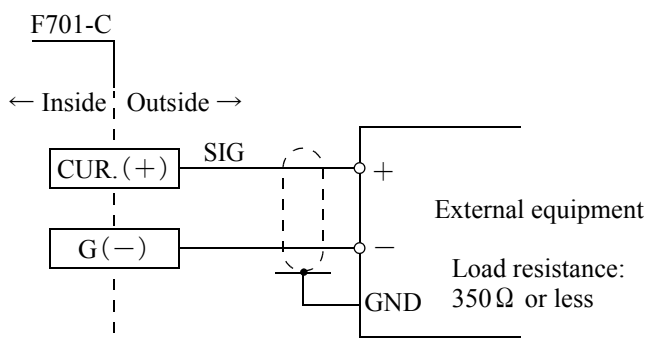
**⚠ CAUTION**

Do not apply voltage or current to the current output terminal externally by mistake.
Doing so will cause breakage.

10-4-2. Specifications

Weight values are output as converted to analog signals of current.
Zero output weight value and full scale weight value can be set.

Current output	4mA ~ 20mA (Load resistance 350 Ω or less)
D/A conversion speed	200 times/sec.
Resolution	1/10000
Over range	$\pm 5\%$ of the full scale (3.2mA ~ 20.8mA)
Zero drift	Within 0.3 μ V/ $^{\circ}$ C
Gain drift	Within 30ppm/ $^{\circ}$ C
Non-linearity	Within 0.02%/FS
	※ Not including the drift of the analog input section
Output connector	Cage clamp type terminal board (two-piece type)
Potentiometer	A potentiometer to readjust (fine-adjust) ZERO (4mA) and GAIN (20mA) is placed on the rear panel. (The adjustable range is a few percentage.) (4mA and 20mA are factory-adjusted.)

10-4-3. Method of Adjusting the D/A Zero and Gain

The D/A converter of the F701-C obtains analog output by setting the weight value to output 4mA of current and the weight value to output 20mA of current, respectively. Input each setting value and select D/A Output Mode in setting mode 4.

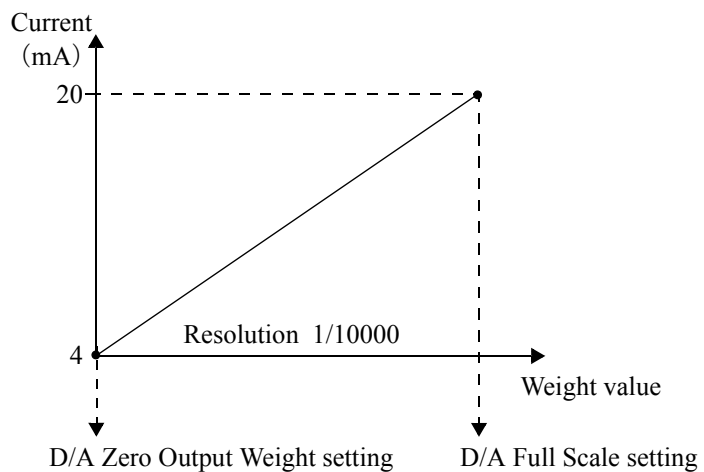

a) D/A Output Mode**b) D/A Zero Output Weight** (Input range / 0 ~ 99999 or Capacity)**c) D/A Full Scale** (Input range / 0 ~ 99999 or Capacity)**Operation****a)**

1) Select setting mode 4.

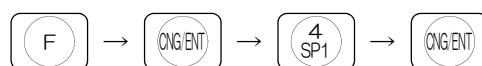

2) Set Test mode and Output mode. (1-D/A Output Mode)

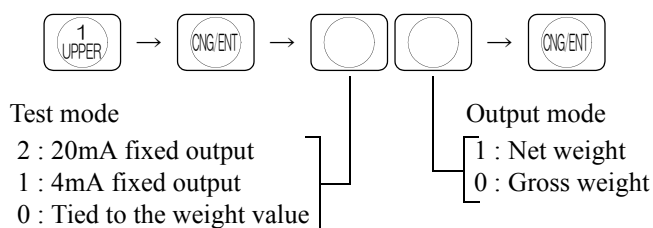
**b)**

1) Select setting mode 4.

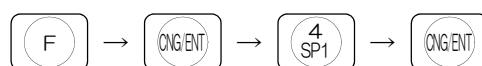

2) Input the D/A Zero Output Weight. (2-D/A Zero Output Weight)

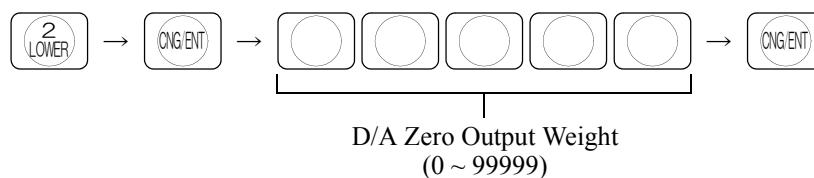

Input the weight value to output 4mA.
 The default value is "00000".

c)

1) Select setting mode 4.

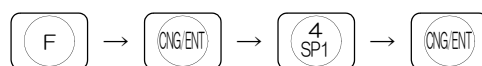

2) Input the D/A Full Scale. (3-D/A Full Scale)

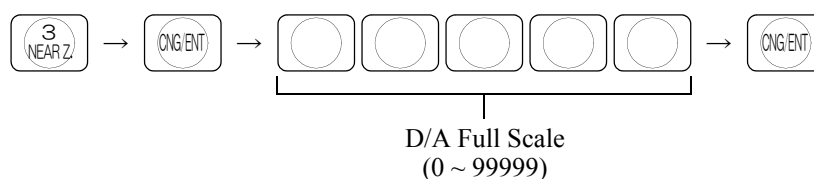

Input the weight value to output 20mA.
 The default value is "10000".

Example

When setting is as follows:

D/A Output Mode 01
 D/A Zero Output Weight..... 00500
 D/A Full Scale..... 02500

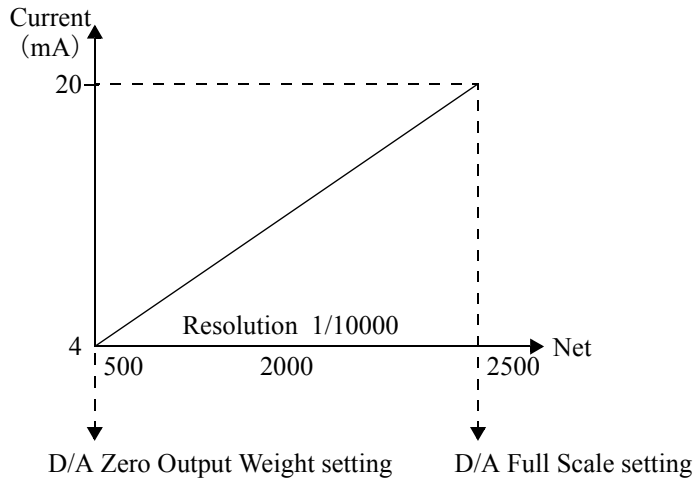

Net	Current (mA)
480	3.84
Zero → 500	4.00
1000	8.00
1500	12.00
Full scale → 2500	20.00
2520	20.16

10-4-4. About D/A Resolution

The resolution of the D/A converter is 1/10000 with respect to 4 ~ 20mA.

That is, the minimum unit of current is as follows:

$$(20 \sim 4\text{mA}) \times 1/10000 = 1.6 \mu \text{A}$$

Also, the minimum unit of weight value is as follows:

$$(\text{D/A Full Scale setting value}) \times 1/10000$$

10-5. RS-485 Communication Interface

10-5-1. Communication Specifications

◇ Specifications

Signal level	:	Based on RS-485
Transmission distance	:	Approx. 1km
Transmitting method	:	Asynchronous, Full duplex
Transmitting speed	:	1200, 2400, 4800, 9600, 19200, 38400bps selectable
Bit configuration	:	Start : 1bit
		Character length : 7 or 8bit selectable
		Stop : 1 or 2bit selectable
		Parity : None, Odd or Even selectable
Code	:	ASCII

10-5-2. RS-485 Connection

◇ One to one connection

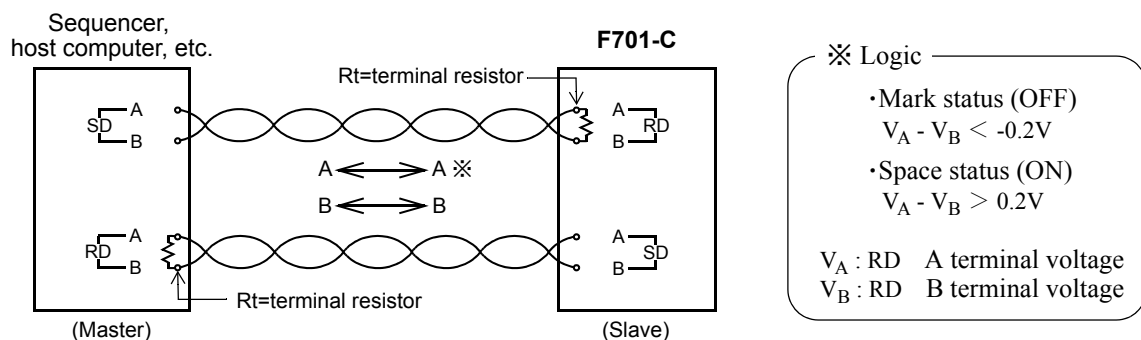

- Use a twisted pair cable for connection. (The noise margin will increase.) However, a twin cable is sufficient for short-distance connection.

- Couple a terminal resistor of 100 ~ 200 Ω to the receiving end.

- The F701-C side has internal terminal resistor. By turning ON the Rt switch, it is not necessary to install external resistance.

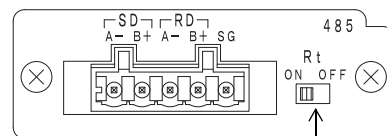

Turn ON the Rt switch.

- The terminal SG is a grand terminal used

on the circuit for protecting the circuit. When the main body of F701-C and the device connected to F701-C are grounded by D type ground, there is usually no need to use the terminal SG.

However, confirm the specifications of the device connected before connecting the terminal SG, when it is necessary to connect it according to the situation of the site.

Request

Some sequencer manufacturers express A and B in reverse.

If communications are unsuccessful, interchange A and B.

◇ One to multiple connection

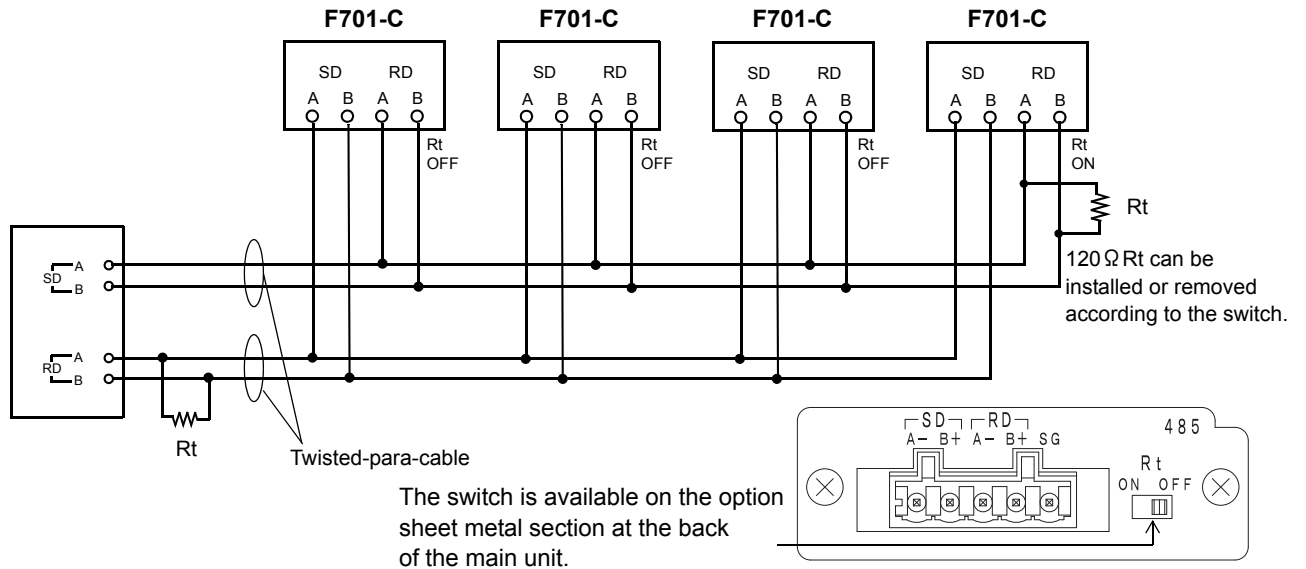

10-5-3. Setting Values for RS-485

1. Set the RS-485 port of this equipment.

Operation

1) Select setting mode 4.

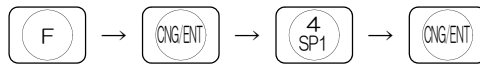

2) Set the RS-485 port. (4-RS-485 I/F)

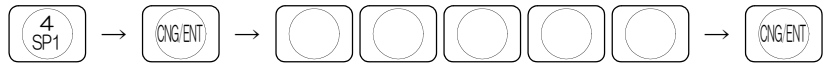

Baud rate

- 5 : 38400bps
- 4 : 19200bps
- 3 : 9600bps
- 2 : 4800bps
- 1 : 2400bps
- 0 : 1200bps

Character length

- 1 : 8bit
- 0 : 7bit

Terminator

- 1 : CR+LF
- 0 : CR

Stop bit

- 1 : 2bit
- 0 : 1bit

Parity bit

- 2 : Even
- 1 : Odd
- 0 : None

2. The initial set for RS-485 port of connecting personal computer and sequencer should be the same setting of F701-C.

10-5-4. Communication Method

1. For connecting more than one F701-C, assign an ID number to each F701-C.
 2. When a start command including an ID number is sent from the host, only one F701-C is brought into transmittable condition, in which reading of weight data, reading and changing of setting values, commands, etc., become valid.
 3. Before making another F701-C transmittable, be sure to send an end command.
- ※ Since Tri-state control is performed according to the start command and end command, if only the start command is sent to two or more F701-Cs, their outputs come into collision, so that normal communications cannot be carried out.
4. ID number setting.

Operation

1) Select setting mode 4.

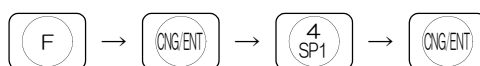

2) Input the ID Number. (5-ID Number)

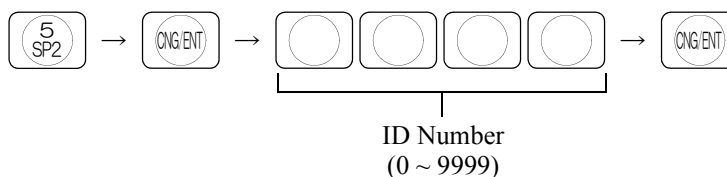

- ※ When the ID number is 0000, transmittable and receivable conditions are brought about at power-on, therefore set ID numbers other than 0000 for connecting two or more F701-Cs.
- ※ If the ID number setting is other than 0000, other formats (R · · · , W · · · , C · · · , etc.) are invalid until the following start command is accepted after power-on.

5. Start command.

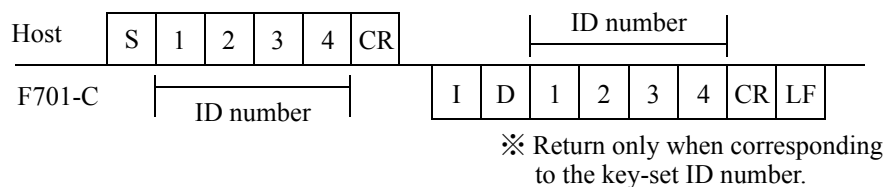

6. End command.

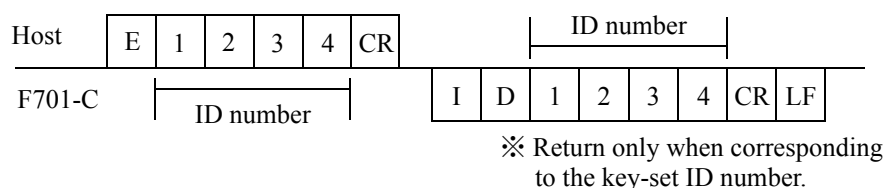

10-5-5. Communication Format

- Reading out the Gross weight (sign, 5-digit weight value, decimal point)

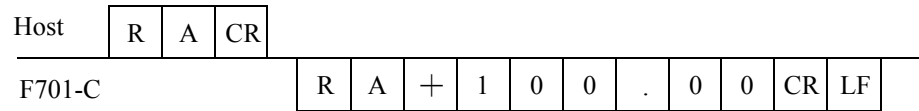

- Reading out the Net weight (sign, 5-digit weight value, decimal point)

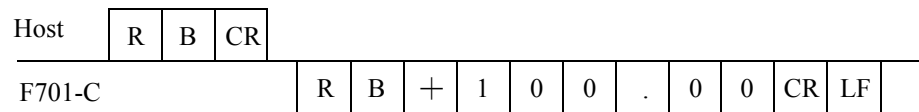

- Reading out the Tare weight (sign, 5-digit weight value, decimal point)

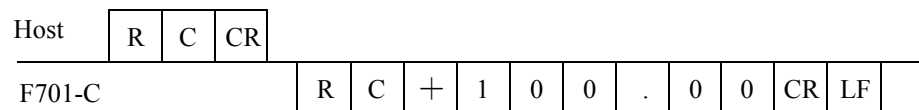

- Reading out the status 1 (7-digit)

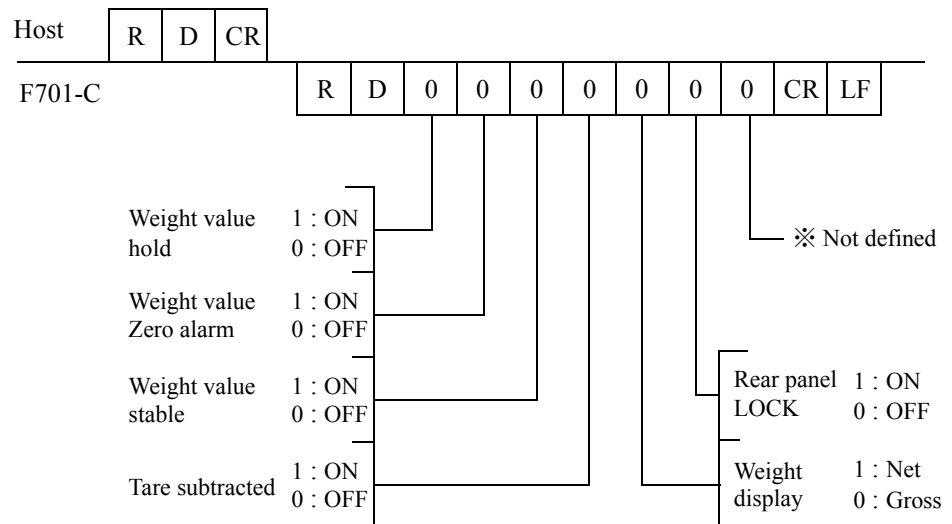

• Reading out the status 2 (7-digit)

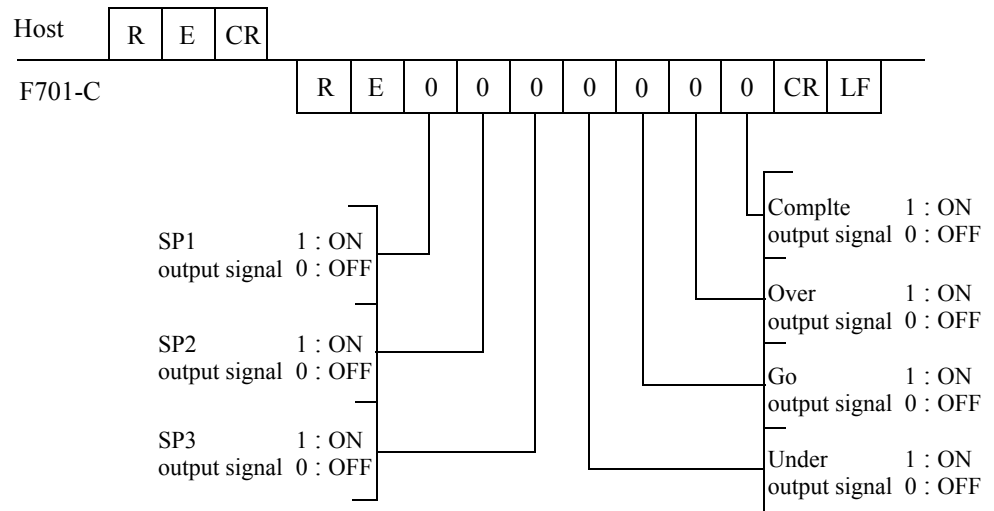

• Reading out the status 3 (7-digit)

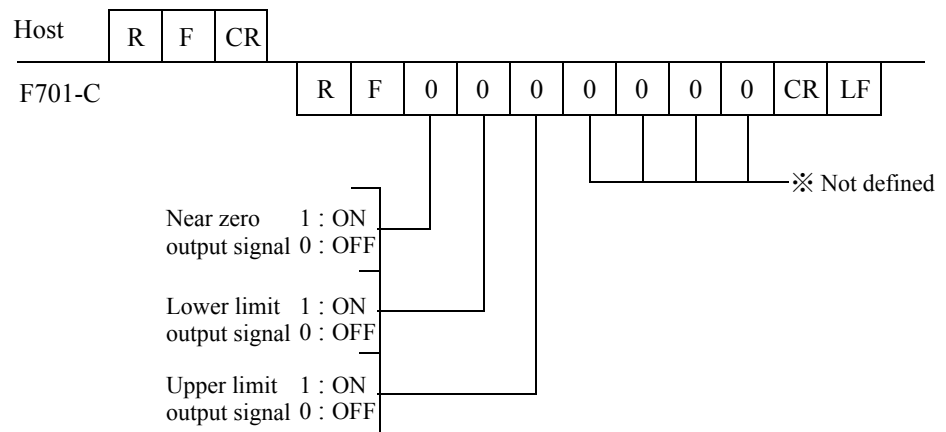

• Reading out the status 4 (7-digit)

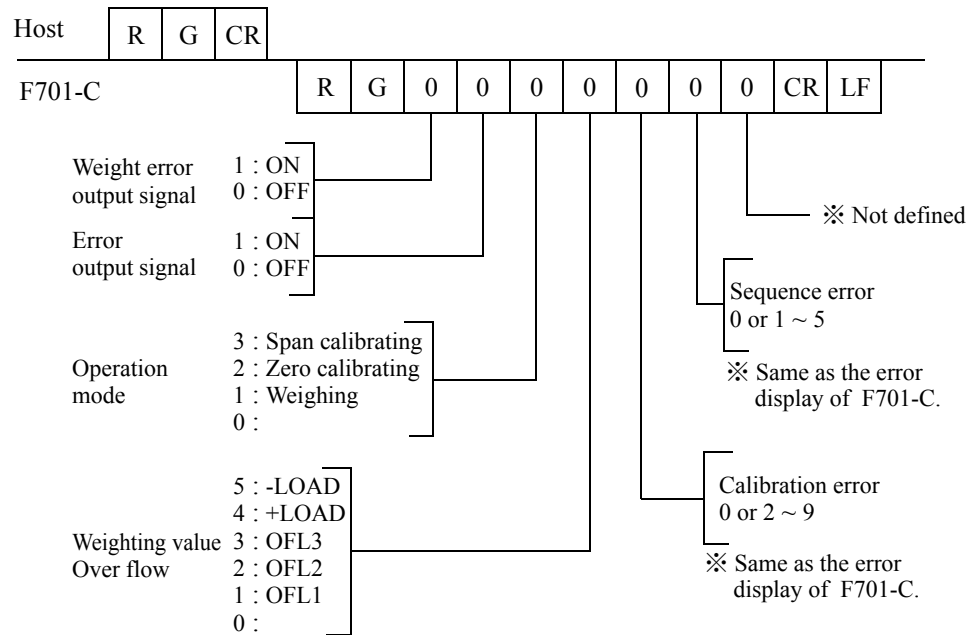

• Read out the count of data (accumulation times : 5-digit)

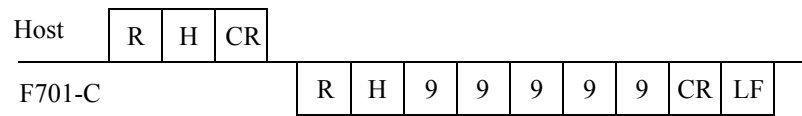

• Read out the accumulated value (9-digit, decimal point)

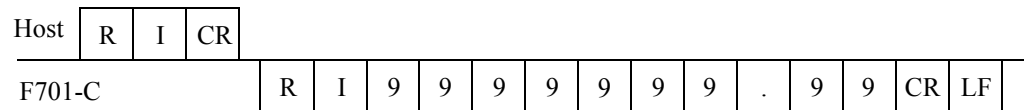

• Read out the accumulated data

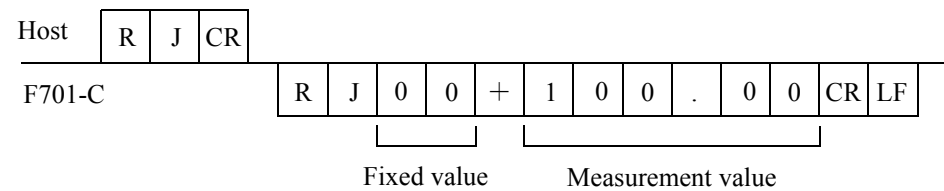

* Up to 256 pieces of data can be stored in the buffer in memory.
 Reading-out erases data chronologically.

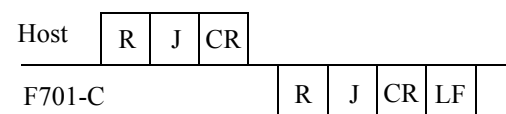

Data returned when there is no accumulated data in the buffer.

• Write in the set value

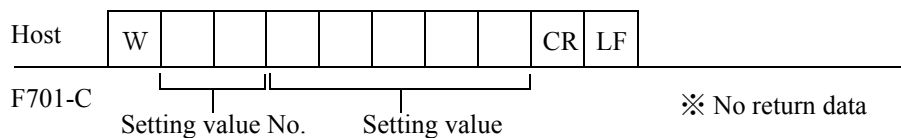

※ For setting value No., refer to "Setting value communication format" on P.152.

• Read out the set value

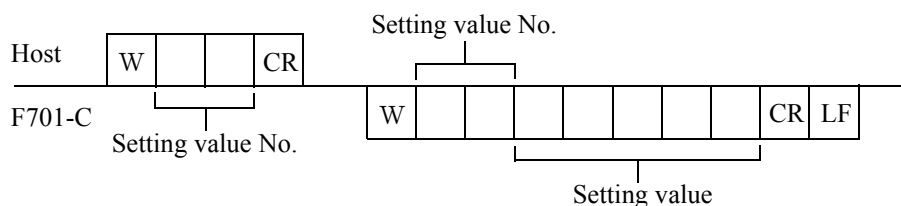

※ For setting value No., refer to "Setting value communication format" on P.152.

• Zero Calibration

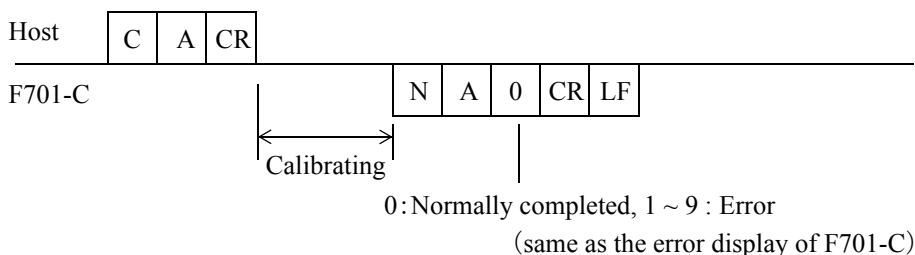

• Span Calibration

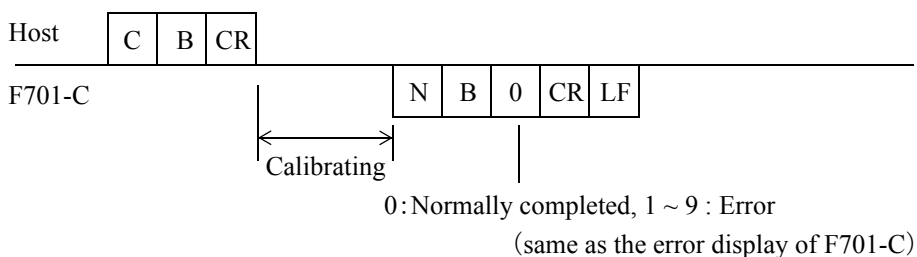

Request

Zero Calibration • Span Calibration

Before sending this command, set the Capacity, Min. Scale division and Balance Weight Value.

• Gross weight selection

Host	C	C	CR
------	---	---	----

F701-C ※ No return data

• Net weight selection

Host	C	D	CR
------	---	---	----

F701-C ※ No return data

• Tare subtraction

Host	C	E	CR
------	---	---	----

F701-C ※ No return data

• Tare subtraction reset

Host	C	F	CR
------	---	---	----

F701-C ※ No return data

• Digital zero

Host	C	G	CR
------	---	---	----

F701-C ※ No return data

• Digital zero reset

Host	C	H	CR
------	---	---	----

F701-C ※ No return data

• Accumulation Command

Host	C	I	CR
------	---	---	----

F701-C ※ No return data

• Accumulation Clear

Host	C	J	CR
------	---	---	----

F701-C ※ No return data

11. OVER SCALE & ERROR

11-1. Over Scale

The weight error output turns ON.

The input of A/D converter overflowed	<i>LoAd</i>
Net weight > Net Over set value	<i>oFL1</i>
Gross weight > Capacity + 9 scale division	<i>oFL2</i>
Gross weight > Gross Over set value	<i>oFL3</i>

※ Net weight = Gross weight - Tare weight

11-2. Sequence Error

The sequence error output turns ON.

Error item	Alarm message
When start signal turns on, the stop signal turns ON.	<i>Err1</i>
During weigh cycle, the stop signal turns ON.	<i>Err2</i>
Zero Alarm turns on according to set times.	<i>Err3</i>
During weigh cycle, Near Zero output signal turns OFF. ("At start, Near Zero confirmation on" is selected for sequence control)	<i>Err4</i>
During weigh cycle, the value \geq SP1 ※ ("At start, weight value confirmation on" is selected for sequence control).	<i>Err5</i>

※ SP1 = Final - Set point 1

11-3. Calibration Error

Error item	Alarm message
Re-do Zero Calibration.	<i>cErr1</i>
The initial Tare is beyond the zero adjustment range.	<i>cErr2</i>
The initial Tare is minus.	<i>cErr3</i>
The input balance weight is beyond the Capacity.	<i>cErr4</i>
The balance weight is "00000".	<i>cErr5</i>
The load cell output dose not reach the span adjustment range.	<i>cErr6</i>
The load cell output is miunus.	<i>cErr7</i>
The load cell output is beyond the span adjustment range.	<i>cErr8</i>
The weight value is not stable and calibration stopped.	<i>cErr9</i>

12. TROUBLE SHOOTING

● Over-scale display

$L O R d$ (A/D converter over)

An input signal from the load cell exceeds F701-C span adjustment range.
 Check whether the output of the load cell is within span adjustment range;
 Check there are breakages in the cable which is connected to the F701-C and the load cell;
 And whether the load cell connector on the rear panel is open or not, when the load cell input terminal board is open (not connected with the load cell) will display “ $L O R d$ ” also.

$- L O R d$ (A/D converter minus over)

An input signal from the load cell is lower than F701-C span adjustment range.
 Check whether the output of the load cell for falling short of the span adjustment range;
 Check there are breakages in the cable which is connected to the F701-C and the load cell;
 And whether the load cell connector on the rear panel is open or not, when the load cell input terminal board is open (not connected with the load cell) will display “ $- L O R d$ ” also.

$O F L I$ (Net weight > Net Over set value)

Net weight exceeds the Net Over set value.
 Decrease the signal coming from the load cell until the normal display returns; or reset the Net Over value.

$O F L J$ (Gross weight > Gross Over set value)

Gross weight exceeds the Gross Over set value.
 Decrease the signal coming from the load cell until the normal display returns; or reset the Gross Over value.

$O F L K$ (Gross weight > Capacity + 9 scale division)

Gross weight exceeds Capacity + 9 scale division.
 Decrease the signal coming from the load cell until the normal display returns.

Request

Scale a Capacity is primary data for the F701-C. You must re-calibrate if Capacity is changed .

Do not change Capacity to reset over scale message ($O F L K$).

● Error display**Err 1 (Sequence error)**

When start signal turns ON, stop signal turns ON.
Turn OFF stop signal then start weighing.

Err 2 (Sequence error)

During weigh cycle, the stop signal turns ON.
Set the stop signal from OFF to ON to resolve the sequence error.

Err 3 (Sequence error)

It is displayed if a ZALM condition is brought about when the auto zero is in operation by sequence control.
Remove the causes of zero out of adjustment (adherents, etc.), and reset the digital zero to resolve the zero alarm.

Err 4 (Sequence error)

During weigh cycle, Near Zero output signal turns OFF ("At start, Near Zero confirmation ON" is selected for sequence control) .
First, check the Near Zero setting value and the Near Zero comparison target. Next, check the following for occurrence:
"A start was made before complete discharge."
"The start ON timing was too early."
"Discharge is in a jam, etc."
Set the stop signal from OFF to ON to resolve the sequence error.

Err 5 (Sequence error)

It is displayed if the Set Point 1 output (SP1) signal is ON when weighing starts (when it is set to check the weight value when weighing starts).
First, check the Set Point 1 setting value and Final setting value. Next, check the following for occurrence:
"A start was made before complete discharge."
"The start ON timing was too early."
"Discharge is in a jam, etc."
Set the stop signal from OFF to ON to resolve the sequence error.



Refer to "6-2.Simple Comparison Control and Sequence Control" on P.75 for more details.

ε E r r 3 (Calibration error)

Initial dead load is negative.

Check that load cell is mounted in the correct direction; check that load is being applied to the load cell in the correct direction ; check that the +SIG and -SIG lines are properly connected.

If ε E r r 3 still displayed, connect a resistor between -EXC and -SIG load cell connections. This should shift the zero point. Do Zero Calibration again.

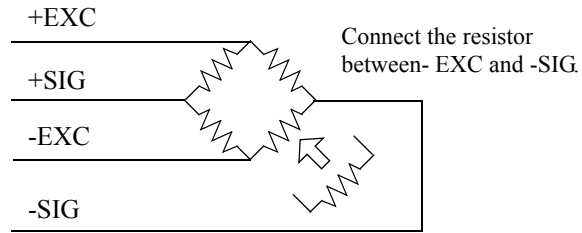

ε E r r 4 (Calibration error)

The Balance Weight Value is larger than the Capacity.

Re-enter the Balance Weight Value equal to or less than the Capacity.

Do Span Calibration again.

The relationship between Capacity and Balance Weight Value

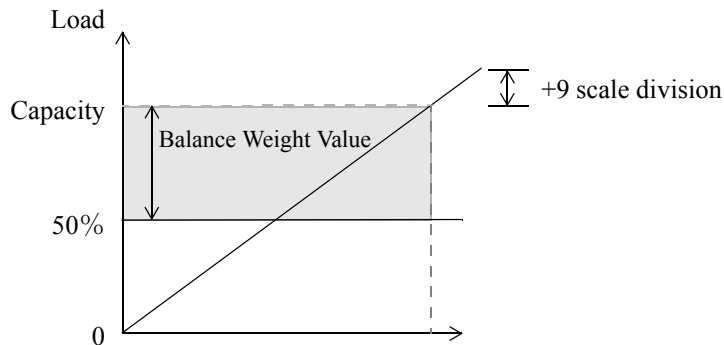

Balance Weight Value must be between 50% to 100% of Capacity in order to do Span Calibration correctly.

ε E r r 5 (Calibration error)

The set Balance Weight Value is "00000". Set adequate value to Balance Weight Value.

ε E r r 6 (Calibration error)

The load cell output dose not reach the span adjustment range of the F701-C.

Check how load is applied to load cell; check load cell has sufficient output (mV/V) to reach span range. Do Span Calibration again.

Or, when an equivalent calibration is done by resolution that exceeds 1/10000, it is assumed the one not reaching within the range of the span adjustment.

エラー 7 (Calibration error)

Load cell output is negative.

Check that load cell is mounted in the correct direction; check that load is being applied to the load cell in the correct direction; check that the +SIG and -SIG lines are properly connected. Do Span Calibration again.

エラー 8 (Calibration error)

Load cell output is beyond span adjustment range of the F701-C.

Check how load is applied to load cell; check load cell has sufficient output (mV/V) to reach span range. Do Span Calibration again.

エラー 9 (Calibration error)

The load is not stable enough for correct Calibration.

Adjust the stable period and stable range of Motion Detection so “ $\overline{\text{STAB}}$ ” display lights during Calibration. Do Calibration again.



The span adjustable range of the F701-C is 0.3 ~ 3.2 (mV/V). Since display to the Capacity is guaranteed in Span Calibration, calibration cannot be performed if the load cell output is under 0.3 (mV/V) (エラー 8) or exceeds 3.2 (mV/V) (エラー 9) when the Capacity is reached.

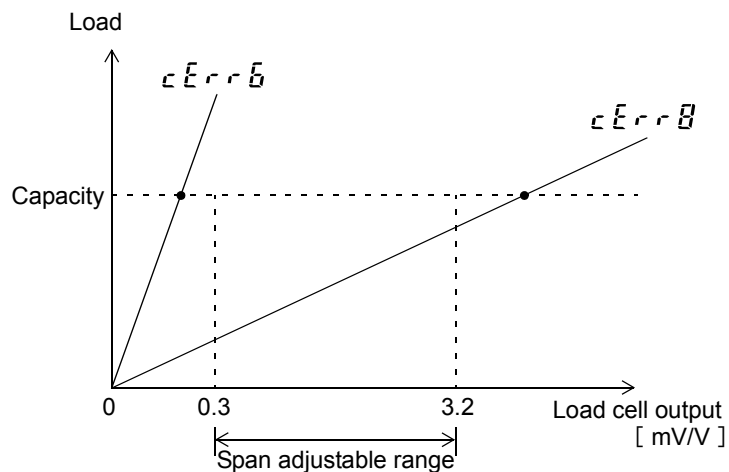

● **EXC error display**

EXC Error (EXC Error)

The load cell excitation voltage has dropped.

Check the cables connecting the F701-C and load cell for excessive load, and check to see if the wiring is correct.

● **Battery alarm display**

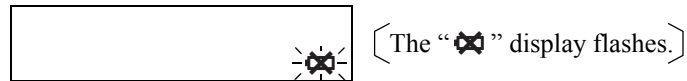

The voltage of the lithium battery for memory backup has dropped.

Replace with a new battery.

For the method of replacement, refer to "13.REPLACEMENT OF THE BACKUP BATTERY" on P.163.

● **The setting value is not changed.**

There is a possibility that writing to the NOV RAM is interrupted, so that the setting value is not changed.

If any setting value stored in the NOV RAM (refer to "18.THE LIST OF INITIAL SETTING VALUE" on P.173) is changed, the “•” (position shown below) lights (may not light in some cases).

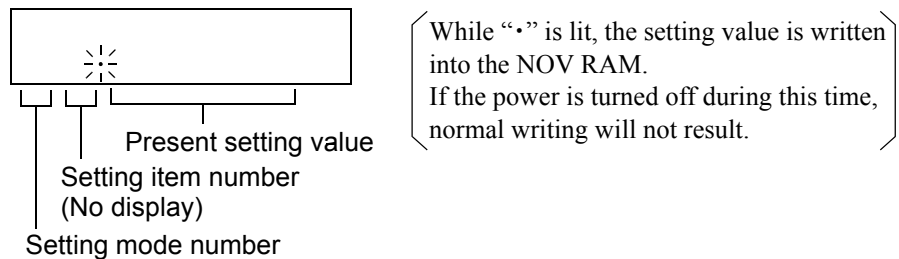

While “•” is lit, do not turn off the power of the F701-C.

● **Setting values have been changed when the power is turned on.**

The voltage of the lithium battery for memory backup may have dropped.

The setting values stored in the SRAM (refer to "18.THE LIST OF INITIAL SETTING VALUE" on P.173) are backed up by the lithium battery.

If the power of the F701-C is turned off with the voltage of the lithium battery having dropped, the setting values are lost.

Replace the lithium battery, and change the setting values again.

※ For the battery alarm, refer to "Battery alarm display" on P.161.

※ For the method of replacing the lithium battery, refer to "13.REPLACEMENT OF THE BACKUP BATTERY" on P.163.

● Self-check error display**Error 1 (RAM check error)**

It is displayed if a RAM check error occurs in self-checking.

Error 2 (Checksum error)

It is displayed if a checksum error occurs in self-checking or at power-on.

Error 3 (NOV RAM check error)

It is displayed if a NOV RAM check error occurs in self-checking.

* In the case of self-check error display, the F701-C is faulty.

Request repair from your distributor or us.

13. REPLACEMENT OF THE BACKUP BATTERY

The life of the lithium battery for memory backup is approx. 7 years. For replacement of the battery, send the F701-C to us in a manner similar to repair. Since the setting values in the “SRAM” (refer to "18.THE LIST OF INITIAL SETTING VALUE" on P.173) are lost when the battery is removed, record the setting values beforehand. If the F701-C cannot be moved from the installation location, replace as follows:

1. Pull out the power cable from the main unit.
2. Remove the two M3 screws at the top of the rear panel, and pull out the upper cover by sliding it.

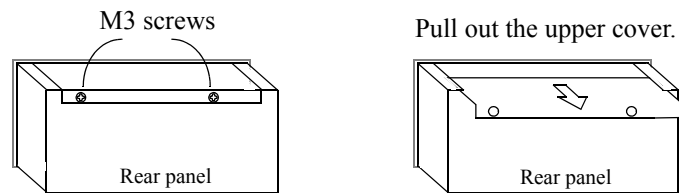

3. Remove the connector.
4. Remove the screw fixing the nylon clamp, and replace the lithium battery with a new one.

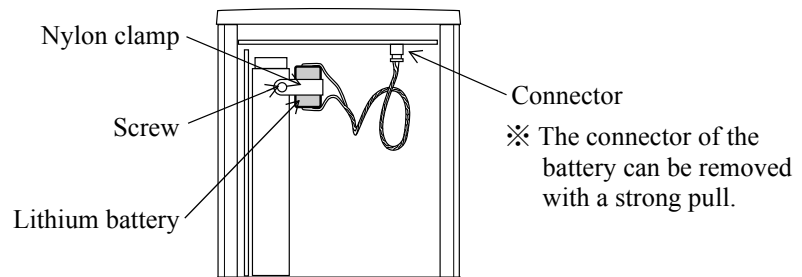

※ Replacement battery: CR14250SE

We deal with it. Specify the lithium battery for the F701-C.

5. After connection of the connector of the new lithium battery, make a cold start.

※ While pressing the  and  keys at the same time, turn on the power.

Initial values are written into the “SRAM” as setting values. (refer to "18.THE LIST OF INITIAL SETTING VALUE" on P.173)

Request

The setting values in the “SRAM” (refer to "18.THE LIST OF INITIAL SETTING VALUE" on P.173) are lost when the battery is removed. Record the setting values beforehand.

14. BLOCK DIAGRAM

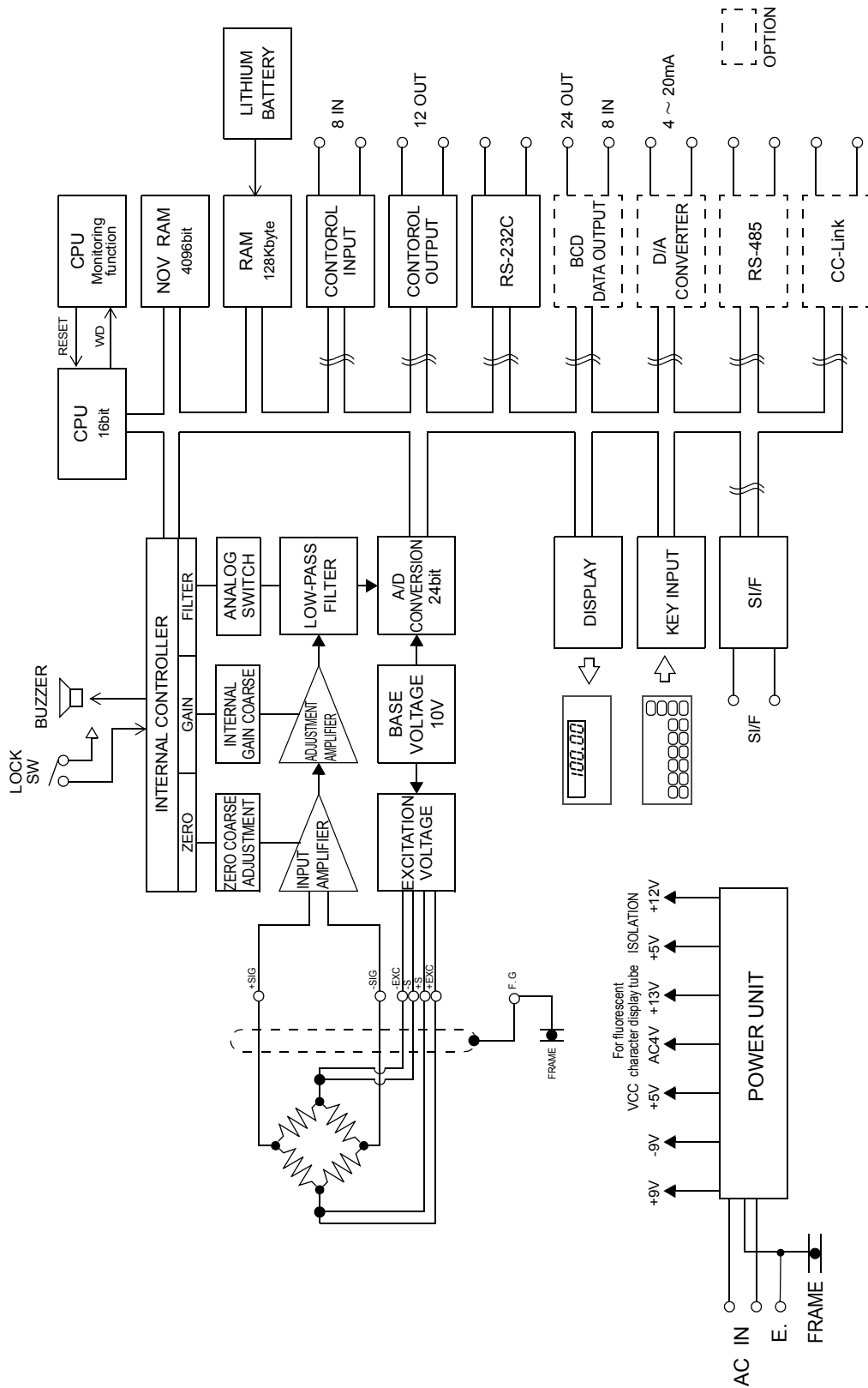

⎵ : Indicates the insulation by Photo coupler.

--- : OPTION

15. DIMENSIONS

Unit:mm

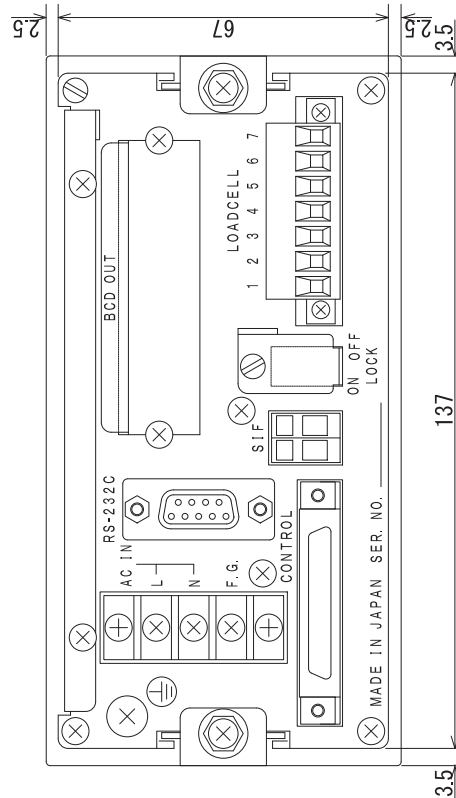
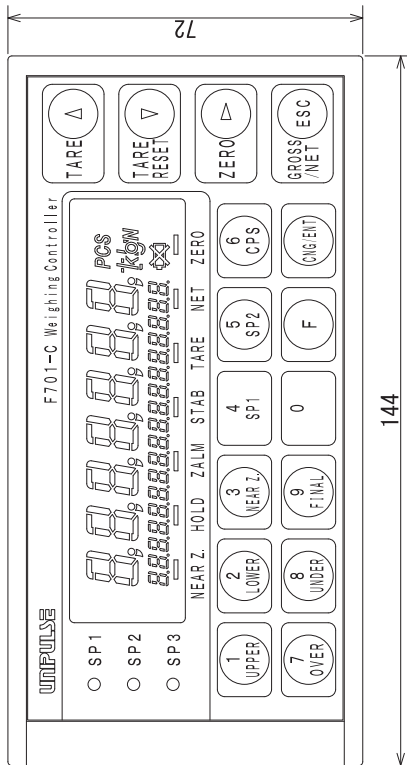
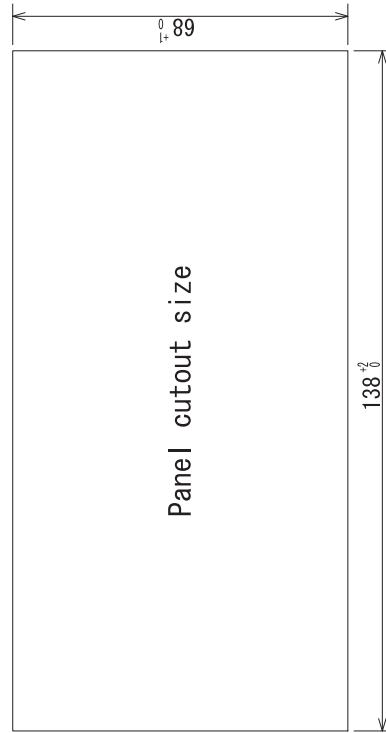
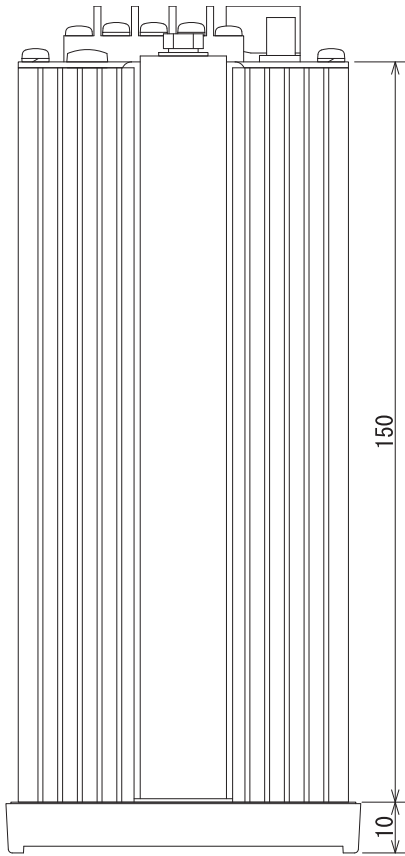

16. MOUNTING ON A PANEL

Please follow the procedure for mounting a panel to F701-C.

- (1) Make a hole in the mounting panel.

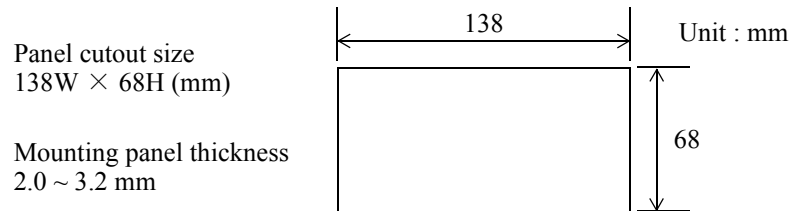

- (2) Remove the mounting rails on both sides of the indicator, and insert the indicator into the panel.

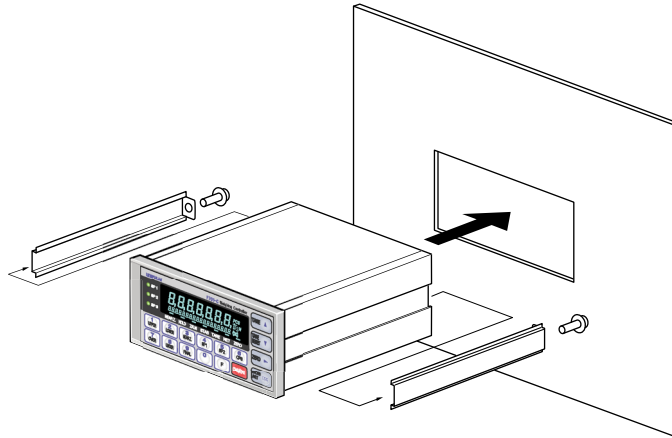

- (3) Insert the mounting rails into both sides from the back of the indicator.

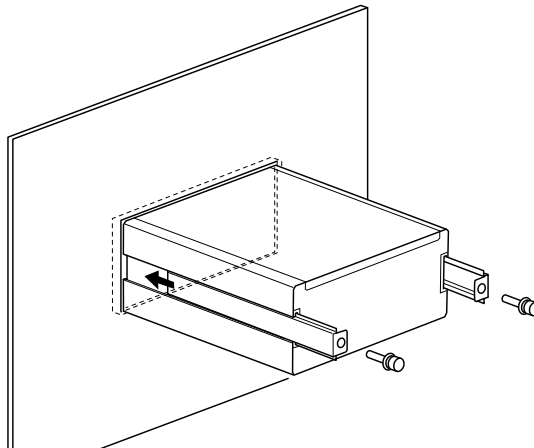

- (4) Securely fix the mounting hardware on both sides with the attached M4 screws.

CAUTION

For transportation after panel-mounting, consideration should be given so as not to give excessive shocks or vibration.

17. SPECIFICATIONS

17-1. Analog Section

Excitation voltage	DC10V \pm 5% Output current : within 120mA Remote sense type (Up to four 350 Ω load cells can be connected in parallel.)
Zero adjustment range	0 ~ 2mV/V Coarse adjustment: Digital control by course adjustment circuit Fine adjustment: Automatic adjustment by digital operation
Gain adjustment range	0.3 ~ 3.2mV/V Coarse adjustment: Digital control by course adjustment circuit Fine adjustment: Automatic adjustment by digital operation
Minimum input sensitivity	0.3 μ V/count
Accuracy	Non-linearity : within 0.01%/FS (Typ 0.005%/FS ordinary) Zero drift : within 0.2 μ V/ $^{\circ}$ C RTI (Typ 0.15 μ V/ $^{\circ}$ C) Gain drift : within 15ppm/ $^{\circ}$ C (Typ 5ppm/ $^{\circ}$ C)
Analog filter	Bessel type low-pass filter (-12dB/oct) Selectable from 2, 4, 6 and 8Hz
A/D converter	Speed : 200 times/sec. Resolution : 24bit (binary)
Minimum indication resolution	1/10000 (when 1/4 scale division is valid) 1/40000 (when 1/4 scale division is invalid)
Secondary calibration	Equivalent Calibration Minimum indication resolution for secondary calibration : 1/1000 (ordinary temperature)

17-2. Display Section

Display	
Main display :	Numerical display (7-digit) by fluorescent character display tube; 10.4mm in character height
Subdisplay :	Numerical display (18-digit) by fluorescent character display tube; 4.0mm in character height
Indicated value	5-digit, sign: negative display at the highest digit
Unit	Label attached (t, kg, g, N, lb)
Capacity	Setting allowable in the range of 0 ~ 99999.
Min. scale division	Setting allowable in the range of 1 ~ 100.
Decimal point	Select from 0, 0.0, 0.00 or 0.000
Over display	A/D converter input over LOAD Net Over OFL1 Capacity + 9 scale division OFL2 Gross Over OFL3
Center zero	A true zero point or the center of each value is displayed.
Display frequency	Select from 3, 6, 13 or 25 times/sec. (The system speed is 200 times/sec.)
Status display	SP1, SP2, SP3, NEAR Z, HOLD, ZALM, STAB, TARE, NET, ZERO, 

17-3. Setting Section

Setting method	Setting by keyboard operation (embossed membrane switches with key click sound) External setting also allowable through the RS-232C.
Memory of set values	
Initial values :	NOV RAM (nonvolatile RAM)
Other values :	Lithium-battery-backed-up C-MOS RAM (The memory period is 7 years or more.) (With the lithium battery voltage monitoring function.)
Protection of set values	Setting operation is inhibited so that initial setting values and calibration will not be changed by wrong operation.
Setting item	<ul style="list-style-type: none"> • Upper Limit / Lower Limit / Near Zero / Set Point 1 / Set Point 2 / Compensation / Over / Under / Final • Comparison Inhibit Time / Judging Time / Complete Output Time / Adjust Feeding Time / Auto Zero Times / Judging Times / Auto Free Fall Compensation Regulation / Analog Filter / Tare Weight

- Weighing Function 1 / Weighing Function 2 /
Weighing Function 3 / Sequence Mode /
Function Key Invalid / Digital Filter / Motion Detection /
Zero Tracking Period / Zero Tracking Range
- Balance Weight Value / Capacity / Min. Scale Division /
Net Over / Gross Over / DZ Regulation Value /
Function Selection /
Gravitation Acceleration (area number input) /
Gravitation Acceleration (acceleration input)
- D/A Output Mode / D/A Zero Output Weight / D/A Full Scale /
RS-485 I/F / ID Number / RS-232C I/F /
External Function Selection / Setting Value LOCK /
Restriction on the Tare Subtraction Function
- Optional Board
- Input Selection / Output Selection /
CC-Link I/F Occupied station & Transmission speed /
CC-Link Station No.
- Span Calibration / Equivalent Calibration / Pass Word /
Zero Calibration

17-4. External Input/Output

Input signals (8 points)	G • N / Digital Zero / Tare ON / Tare OFF / Hold / Judge / Feed • Discharge / Start / Stop / Accumulation Command / Accumulation Clear ON when short-circuited with the COM terminal by contact (relay, switch, etc.) or non-contact (transistor, open collector output, etc.)
Output signals (12 points)	Near Zero / SP1 / SP2 / SP3 / Under / Over / Upper Limit / Lower Limit / Stab / Weight Error • Error / Go • Complete / RUN • Accumulation Error Transistor open collector output (Emitter = COM terminal) Output LO with transistor ON.

17-5. Interface

< Standard equipment >

Two-wire serial interface [SI/F]

Serial interface to connect a UNIPULSE-manufactured printer, external display, etc.

Transmitting method : Asynchronous

Transmitting speed : 600bps

RS-232C communication interface [232]

Writing, changing, reading, etc., of weight data and various types of status, and additionally various setting values are carried out by commands from the host computer.

Signal level	: Based on RS-232C
Transmission distance	: Approx. 15m
Transmitting method	: Asynchronous
Transmitting speed	: 1200, 2400, 4800, 9600, 19200 or 38400bps selectable
Bit configuration	: Star : 1bit
	Character length : 7 or 8bit selectable
	Stop : 1 or 2bit selectable
	Parity : None, Odd or Even selectable
Code	: ASCII

< Option > (Number of options mountable: 1)

BCD parallel data output interface [BCO]

Parallel interface to send weight data to a printer, external display or various sorts of data processing equipment.

The Input/Output singles are photocoupler-insulated from the internal circuits.

Output signal	: Weight data (5 digits)
Output logic	: Positive/Negative selectable
Output circuit	: Open-collector
Input signal	: Logic switching, hold, output data selection
Input circuit	: Operated by a contact or an open-collector circuit (Ic=10mA min.)

D/A converter [DAC]

Weight values are output as converted to analog signals of current.

Zero output weight value and full scale weight value can be set.

• D/A converter

Current output	: 4 ~ 20mA
D/A conversion speed	: 200 times/sec.
Resolution	: 1/10000
Over range	: $\pm 5\%$ of the full scale Current 3.2mA ~ 20.8mA
Zero drift	: Within $0.3 \mu\text{V}/^\circ\text{C}$
Gain drift	: Within 30ppm/ $^\circ\text{C}$
Non-linearity	: Within 0.02%/FS
	※Not including the drift of the analog input section

RS-485 communication interface [485]

Compared with the RS-232C, longer-distance communications can be carried out.

Furthermore, two or more F701-Cs can be connected in parallel by setting ID numbers.

Signal level	: RS-485
Transmission distance	: Approx. 1km
Transmitting method	: Asynchronous, Full duplex
Transmitting speed	: 1200, 2400, 4800, 9600, 19200 or 38400bps selectable
Bit configuration	: Start :1bit : Character length :7 or 8bit selectable : Stop :1 or 2bit selectable : Parity :None, Odd or Even selectable
Code	: ASCII

CC-Link interface [CCL]

Links directly to PLC.

CC-Link I/F operates as the remote device stations corresponding to

CC-Link Ver.1.10.

Refer to F701-C CC-Link I/F specifications for details.

17-6. General Performance

Power supply voltage	AC100 ~ 240V (+10%, -15%) [free power source 50/60Hz]
Power consumption	Approx. 15VA
Rush current	20A、5mSec : 100V AC mean load state (ordinary temperature, at cold-start time) 40A、5mSec : 200V AC mean load state (ordinary temperature, at cold-start time)
Operating conditions	Temperature : Operation -10 ~ +40 °C Storage -20 ~ +85 °C Humidity : 85%RH or less (non-condensing)
Dimension	144 (W) × 72(H) × 160(D) [mm] ※ Projections excluded
Panel cutout size	138W ($\begin{smallmatrix} +2 \\ -0 \end{smallmatrix}$) × 68H ($\begin{smallmatrix} +1 \\ -0 \end{smallmatrix}$) [mm]
Weight	Approx. 1.0 [kg]

17-7. Attachment

AC input cord (3m).....	1
Minus screw driver (For WAGO terminal).....	1
Control signal Input/Output connector	1
Connector for BCD output (with BCD option)	1
Connector for D/A converter (with D/A converter option)	1
Connector for RS-485 (with the RS-485 option).....	1
Connector for CC-Link (with the CC-Link option).....	1
Operation manual.....	1
Jumper line.....	2



About the power cable

- The power cable attached to this product as standard equipment can be used in the AC100V power supply in Japan. (Official ratings voltage AC125V)

Please use the power cable authorized in the country when you use this product outside Japan.

- Our company sells following resistance pressure cable AC250V (European standard product) separately.

Please purchase it from us when you need after confirming its plug shape/ voltage.

CAAC3P-CEE7/7-B2 : CEE7/7 Plug cable (2m)

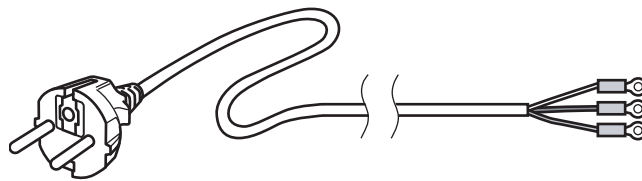

18. THE LIST OF INITIAL SETTING VALUE

- ※ Initial value : Factory-shipped values.
- ※ LOCK 1 : Changing of setting values is inhibited by the software switch (Setting Value LOCK in setting mode 4) (stored in the SRAM).
- ※ LOCK 2 : Changing of setting values is inhibited by the software switch (Setting Value LOCK in setting mode 4) (stored in the NOV RAM).
- ※ LOCK SW : Changing of setting values is inhibited by the LOCK switch on the rear panel (stored in the NOV RAM).
- ※ Display : Setting cannot be changed.

18-1. Setting Mode 0

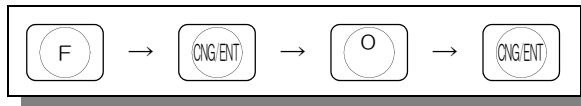

Setting item	Initial value	LOCK 1 (SRAM)	LOCK 2 (NOV.RAM)	LOCK SW (NOV.RAM)	Display
1 Upper Limit	000.00	⊙			
2 Lower Limit	000.00	⊙			
3 Near Zero	000.00	⊙			
4 Set Point 1	000.00	⊙			
5 Set Point 2	000.00	⊙			
6 Compensation	00.00	⊙			
7 Over	0.00	⊙			
8 Under	0.00	⊙			
9 Final	000.00	⊙			

18-2. Setting Mode 1

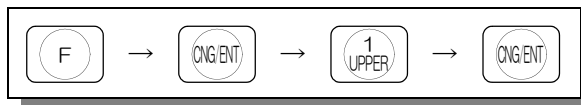

Setting item	Initial value	LOCK 1 (SRAM)	LOCK 2 (NOV.RAM)	LOCK SW (NOV.RAM)	Display
1 Comparison Inhibit Time	0.50		⊙		
2 Judging Time	1.50		⊙		
3 Complete Output Time	3.00		⊙		
4 Adjust Feeding Time	1.00		⊙		
5 Auto Zero Times	01		⊙		
6 Judging Times	01		⊙		
7 Auto Free Fall Compensation Regulation	098.00		⊙		
8 Analog Filter	2		⊙		
9 Tare Weight	000.00	⊙			

18-3. Setting Mode 2

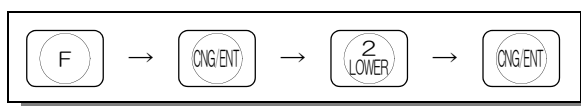

Setting item	Initial value	LOCK 1 (SRAM)	LOCK 2 (NOV.RAM)	LOCK SW (NOV.RAM)	Display
1	Weighing Function 1	0000		⊙	
2	Weighing Function 2	01000		⊙	
3	Weighing Function 3	0141		⊙	
4	Sequence Mode	0000		⊙	
5	Function Key Invalid	1111		⊙	
6	Digital Filter	64		⊙	
7	Motion Detection	1.5-05		⊙	
8	Zero Tracking Period	0.0		⊙	
9	Zero Tracking Range	0000		⊙	

18-4. Setting Mode 3

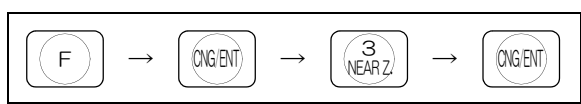

Setting item	Initial value	LOCK 1 (SRAM)	LOCK 2 (NOV.RAM)	LOCK SW (NOV.RAM)	Display
1	Balance Weight Value	100.00		⊙	
2	Capacity	100.00		⊙	
3	Min. Scale Division	0.01		⊙	
4	Net Over	999.99		⊙	
5	Gross Over	999.99		⊙	
6	DZ Regulation Value	02.00		⊙	
7	Function Selection	13213		⊙	
8	Gravitational Acceleration (area number input)	09		⊙	
9	Gravitational Acceleration (acceleration input)	9.798		⊙	

18-5. Setting Mode 4

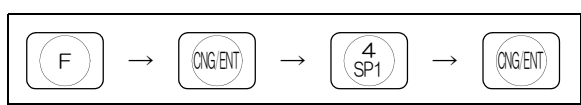

Setting item	Initial value	LOCK 1 (SRAM)	LOCK 2 (NOV.RAM)	LOCK SW (NOV.RAM)	Display
1	D/A Output Mode	00		⊙	
2	D/A Zero Output Weight	00000		⊙	
3	D/A Full Scale	10000		⊙	
4	RS-485 I/F	30101		⊙	
5	ID Number	0000		⊙	
6	RS-232C I/F	30101		⊙	
7	External Function Selection	00000		⊙	
8	Setting Value LOCK	00	← LOCK 1 and LOCK 2 are set up (it memorizes to NOV.RAM)		
9	Restriction on the Tare Subtraction Function	0000		⊙	

*D/A Zero Output Weight and D/A Full Scale cannot be set larger value than the value of Capacity. The value of Capacity automatically reaches a set value.

18-6. Setting Mode 5

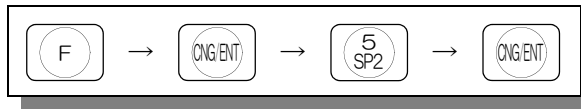

Setting item	Initial value	LOCK 1 (SRAM)	LOCK 2 (NOV.RAM)	LOCK SW (NOV.RAM)	Display
1 Input Selection	0234		⊙		
2 Output Selection	000		⊙		
3 CC-Link I/F Occupied station & Transmission speed	024		⊙		
4 CC-Link I/F Station No.	01		⊙		
5					
6					
7					
8					
9					

18-7. Setting Mode 8

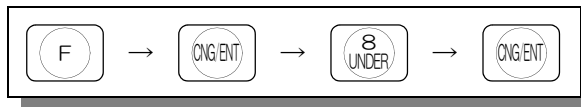

Setting item	Initial value	LOCK 1 (SRAM)	LOCK 2 (NOV.RAM)	LOCK SW (NOV.RAM)	Display
1 Average Weight	000.00				⊙
2 Max. Value	000.00				⊙
3 Min. Value	000.00				⊙
4 General Standard Deviation	000.00				⊙
5 Sample Standard Deviation	000.00				⊙
6 Count of Data	00000				⊙
7 Latest Accumulation Data	000.00				⊙
8 Max. - Min.	000.00				⊙
9 Optional Board	0000				⊙

18-8. Calibration Mode (Setting Mode 9)

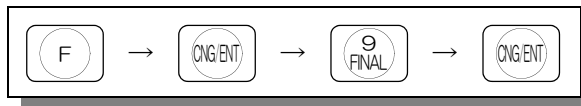

Setting item	Initial value	LOCK 1 (SRAM)	LOCK 2 (NOV.RAM)	LOCK SW (NOV.RAM)	Display
1 Span Calibration	100.00		⊙	⊙	Command
2 Equivalent Calibration	3.0000		⊙	⊙	Command
3					
4					
5					
6					
7					
8					
9 Pass Word	0				
Zero Zero Calibration	0		⊙	⊙	Command

UNIPULSE

Unipulse Corporation

9-11 Nihonbashi Hisamatsucho, Chuo-ku, Tokyo 103-0005

Tel. +81-3-3639-6120 Fax: +81-3-3639-6130